

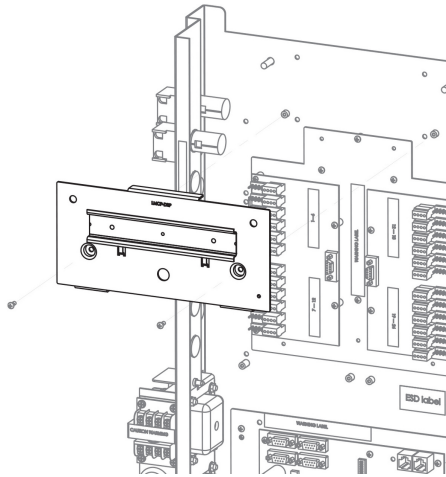

Wattstopper Accessory mounting plate for LMCP panel interiors Part No. LMCP-AMP



The LMCP panel series is designed to provide 0-10V dimming and switching for the control of building lighting and plug loads. The panels can be networked together to enable automation through out an entire facility.

Features & Benefits

Dimming panels dim 0-10V lighting loads as well as switch lighting and plug loads

Switching panels switch lighting and plug loads

Switching panels switch lighting and plug loads

Runs scheduled and photocell events autonomously

HDR relays include a switch for manual override even when panel is powered off

Compatible with Digital Lighting Management switches, sensors and input devices

Native BACnet communications for network control solutions

Easy setup via LMCT-100-2 handheld configuration tool

Specifications

General Info

Product Line	Wattstopper	UPC Number	754182937646
--------------	-------------	------------	--------------

Country Of Origin	China
-------------------	-------

Dimensions

Product Width US	5.0 in	Product Weight US	1.3 lb
------------------	--------	-------------------	--------

Product Volume US	180.6 cu in	Product Depth US	10.75 in
-------------------	-------------	------------------	----------

Product Height US	3.0 in
-------------------	--------

Additional Information

RoHS Conformant	Yes	Security	Yes
-----------------	-----	----------	-----