

PW Ladder Cable Tray Bonding Jumper

ABJ-2000

2000 Amp Aluminum Bonding Jumper

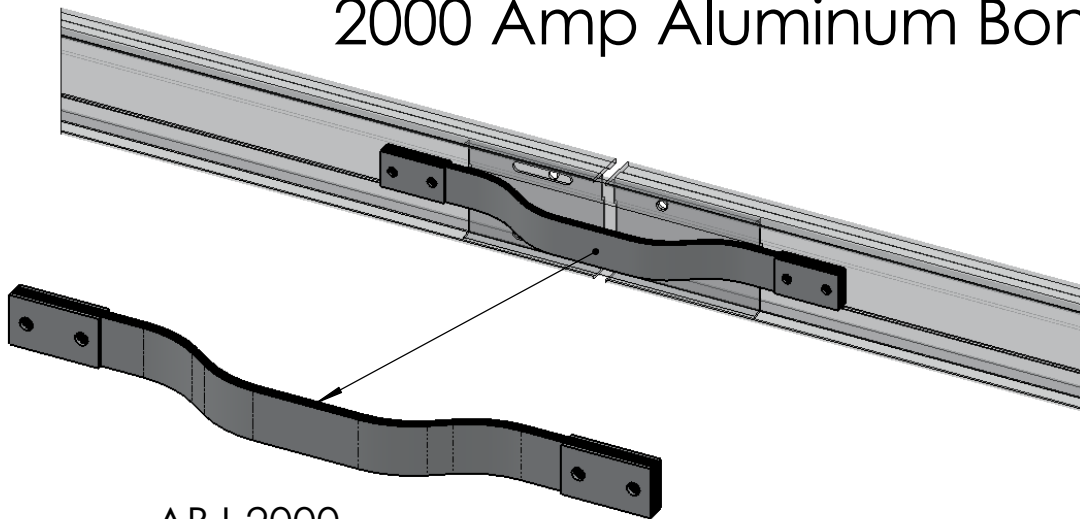

ABJ-2000

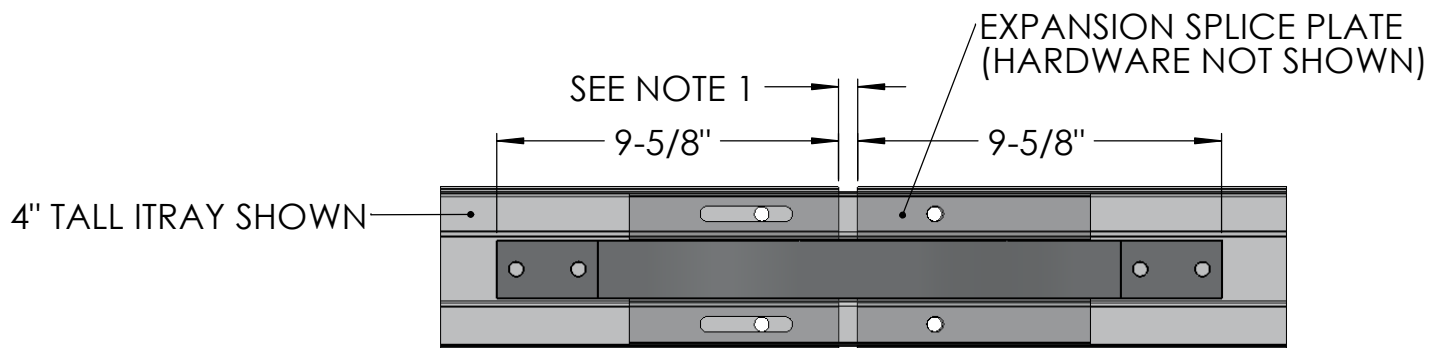

INSTALLATION INSTRUCTIONS:

1. SET PROPER EXPANSION GAP BETWEEN CABLE TRAY ENDS PER NEMA VE-2
2. POSITION END OF BONDING JUMPER 9-5/8" FROM EACH CABLE TRAY END AS SHOWN
(FLEX BONDING JUMPER OUTWARD AS SHOWN IN 3D VIEW ABOVE IF NECESSARY).
3. WITH BONDING JUMPER CENTERED ON CABLE TRAY, MARK HOLE LOCATIONS (4 PLS) OF BONDING JUMPER.
4. THRU-DRILL FOUR HOLES IN SIDERAIL TO 7/16" DIAMETER.
5. RE-POSITION BONDING JUMPER AT PROPER LOCATION, ALIGNING HOLES.
6. INSERT BOLTS FROM 'INSIDE' OF CABLE TRAY, EXTRUDING OUTWARD.
7. INSTALL FLANGED NUT ON OUTSIDE OF BONDING JUMPER, TORQUE EACH TO 19 ft/lbs.

Material: ALUMINUM

Height: 1-1/2"

Length: 21-1/4"

Torque: 19 ft/lbs

"Copyright LNA, Inc. Drawings are proprietary and may not be copied or otherwise duplicated or used without express written permission."

CABCS1191 - ABJ-2000

Legrand
8319 State Rt. 4
Mascoutah, IL 62258 USA
800-658-4641
618-566-3250
Fax 618-566-4978
www.legrand.us/cablofil