

MOUNTED ON RAILS

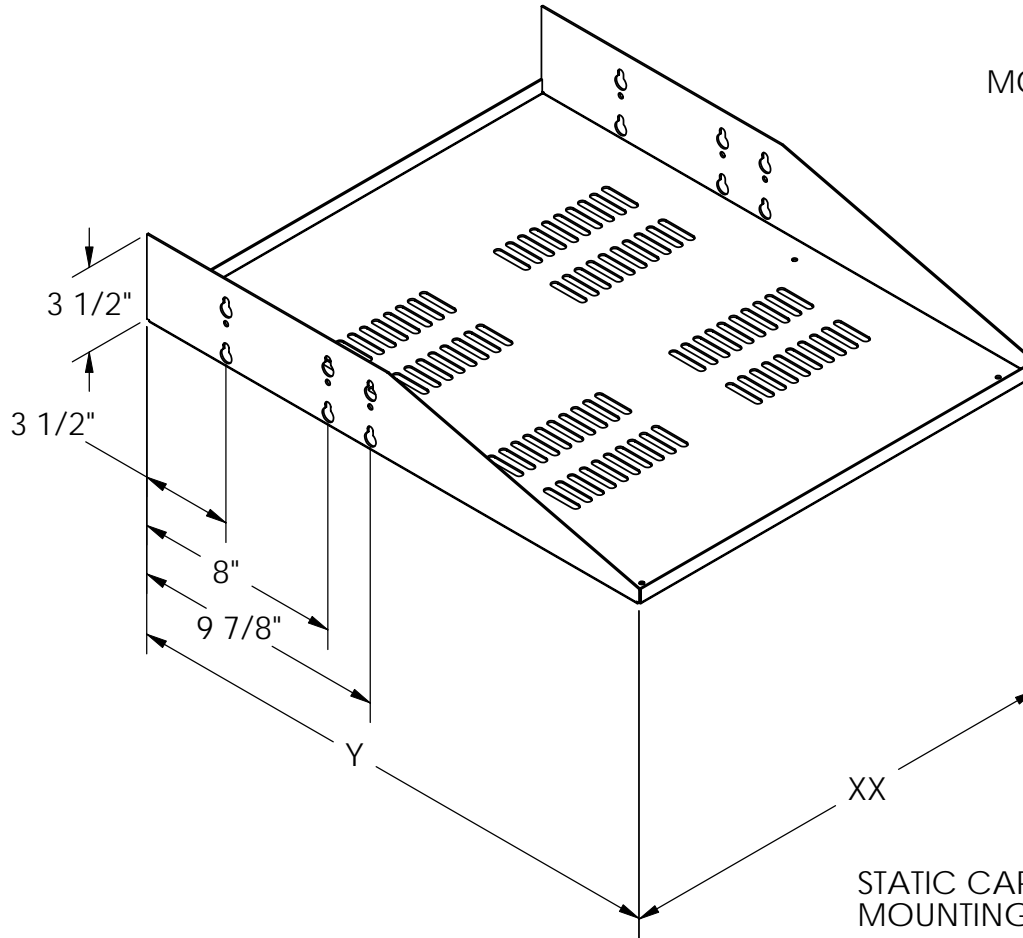

STATIC CAPACITY 150LBS
MOUNTING BRACKETS INCLUDED

PART NUMBER DESIGNATIONS		
PART NUMBER	"XX" = WIDTH	"Y" = DEPTH
OR-ESV-19-3B	17.38"	15.50"
OR-ESV-19-4B	17.38"	21.75"
OR-ESV-23-3B	21.38"	15.50"
OR-ESV-23-4B	21.38"	21.75"

*** NOTICE ***
THIS DOCUMENT CONTAINS CONFIDENTIAL AND/OR PROPRIETARY INFORMATION INTENDED FOR USE ONLY BY THE INDIVIDUAL(S) PROVIDED. NEITHER THIS DOCUMENT, NOR ANY INFORMATION CONTAINED HEREIN, MAY BE COPIED, DISTRIBUTED, DISCLOSED TO ANY THIRD PARTY OR USED IN ANY MANNER OTHER THAN FOR WHICH IT HAS BEEN PROVIDED, WITHOUT THE PRIOR WRITTEN CONSENT OF ORTRONICS, INC. MANUFACTURING RELEASE, PRODUCT SPECIFICATIONS AND STANDARDS ARE SUBJECT TO CHANGE WITHOUT NOTICE.



125 EUGENE O'NEILL DRIVE
NEW LONDON, CT 06320
TEL: 860-445-3800
FAX: 860-405-2990
WWW.ORTRONICS.COM

TITLE
HOMACO VENTED EQUIPMENT SHELF, 19" OR 23" WIDE, 15.50" OR 21.75" DEEP, BLACK

	NAME	DATE	SIZE	CAD FILE	DWG NO	REV
DWN	C.VACCA	07/10/08	A	ESVXXYBC	OR-ESV-XX-YB	01
CHK	S.A.L.	11/10/08	SCALE	NONE	WEIGHT	SHEET
APPR	A.M.	11/10/08				1 OF 1