

Catalog Number(s) • Numéro(s) de Catalogue • Les Numéros de Catalogue: CR12

Country of Origin: Made in USA • Pays d'origine: Fabriqué en USA • País de origen: Hecho en USA



READ & SAVE THESE INSTRUCTIONS!

Electrical Warnings

Properly ground this equipment before use in accordance with both the National Electric Code and local electrical codes and ordinances.

Disconnect the electrical power from the cable reel before any service functions are performed.

Do not use this cable reel for loads greater than the current rating listed on the label and voltage greater than 300V with SJOW-A cable OR 600V with SOW-A cable. The ampacity (current) rating of the cable must be in accordance with the National Electric Code.

Electrical wiring on the reel must be done by a qualified electrician.

Feeder Cord Connection

Power supply should have overcurrent protection to prevent overheating of the reel and cable.

Operational Warnings

Exercise care when handling the cable reel during normal operation. This cable reel has a rotating spool powered by springs under tension.

Do not allow cable to retract without restraining the retraction speed.

Do not disassemble the spring motor for any reason. Serious personal injury could result. This cable reel is equipped with springs under tension. Contact the factory for assistance:

1-800-223-4185

1-877-BY-LEGRAND

Maintenance Warnings

Do not use cable different from that for which the reel is intended. Changes in diameter, weight per foot, length of cable or flexibility will affect the operation of the reel.

Mounting hardware and fasteners should be installed to maintain tightness under vibration and checked periodically to assure tightness.

Overhead installation mountings should be such that the reel is not suspended by bolts in tension. A safety chain or cable is strongly recommended to minimize damage and/or possible injury in the event of mounting failure.

WARNING: Modification of this equipment may cause excessive wear and will void the warranty. Contact the manufacturer regarding changes or modifications of equipment which could affect reliability or safety.

Listed cable reels are intended for General/Commercial/Industrial use and are provided with permanent mounting means. They must be wired by a qualified electrician.

UL/CSA listed cable per rating of reel, as noted on the identification label, to be used for the supply cable (if flexible cable is used) and for the load end cable (active cable).

Electrical Rating

Reels equipped with cable are rated and should not be used at voltages and/or amperes above the rating on the reel. Please consult factory prior to making any changes in volts and amps of cable, as a change could affect reliability or safety.

Cable AWG / # of Cond.	Ampacity
16/3	10.0
16/4	8.0
14/3	15.0
14/4	12.0
12/3	20.0
12/4	16.0

INSTALLATION INSTRUCTIONS

This Cable Reel is factory wired with cable size and length specified at time of purchase. If not included, the load end must be installed per National Electrical Code, and local electrical codes and ordinances.

APPLICATION TYPES

Stretch Applications

The cable is suspended without any intermediate support. Stretch reels generally require a line pull equal to two times the weight of the cable, which allows approximately 10% sag at full extension. On long applications where sag cannot be tolerated, it is sometimes desirable to put supports at intervals of 5 to 10 feet. See Figure 1.

Lift Applications

The cable is lifted vertically in lift applications. The reel is normally designed to handle only the total weight of the cable. Some lift applications may require a ball stop and ratchet to control the length of cable to be retracted. See Figure 2.

Drag Applications

The reel is mounted on a stationary object and is required to drag the cable over the surface to the reel. The cable is supported by the ground or some type of cable tray. A ball stop may be required. All 1200 Series reels sold with cable have a ball stop installed on the reel. See Figure 3.

Retrieve Applications

The reel is mounted on the moving object and winds up or pays out the cable as the machine approaches or moves away from the fixed end. See Figure 4.

MOUNTING

Standard Mounting

The reel may be mounted by bolting the base to any flat surface which is structurally sound enough to support it and the forces of winding and unwinding the cable.

The spool drum must rotate on a horizontal axis.

The reel should be oriented so that the cable extends perpendicular to the rotation of the spool. The cable deflection should not exceed 15° to either side of center. See Figure 5.

If deflection is constant to either side of the reel and operation is impaired, re-mount the reel. See Figure 5.

If the total angle of deflection exceeds 30° a Pivot Base should be used, otherwise excessive cable wear and unreliable operation will result.

We recommend a safety chain for all overhead installations. Attach the safety chain using the 0.39 hole provided in the base.

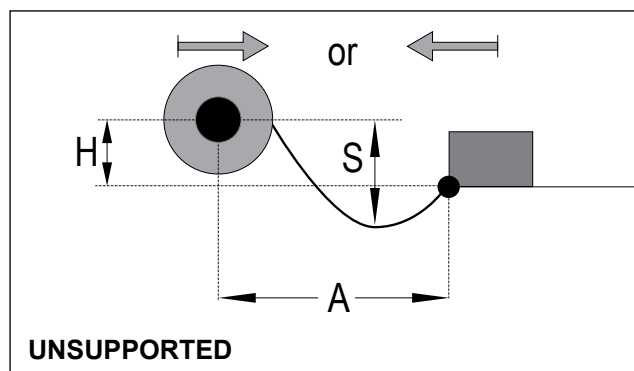

Figure 1 Stretch Application

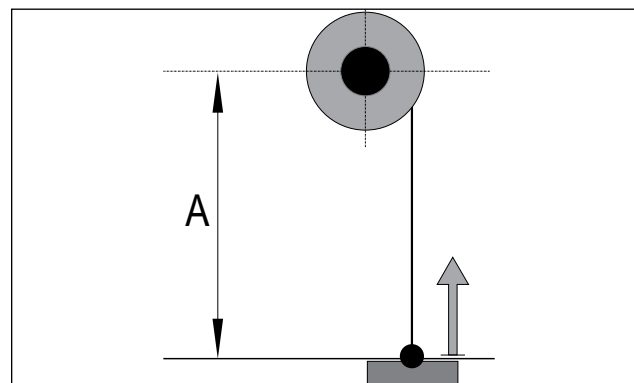

Figure 2 Lift Application

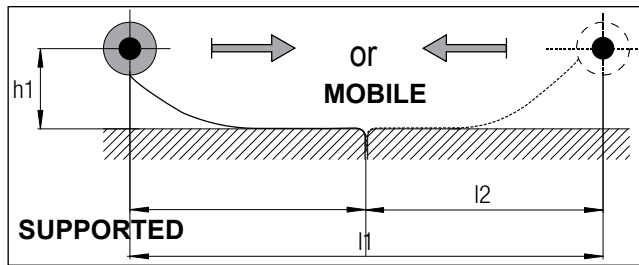

Figure 3 Drag Application

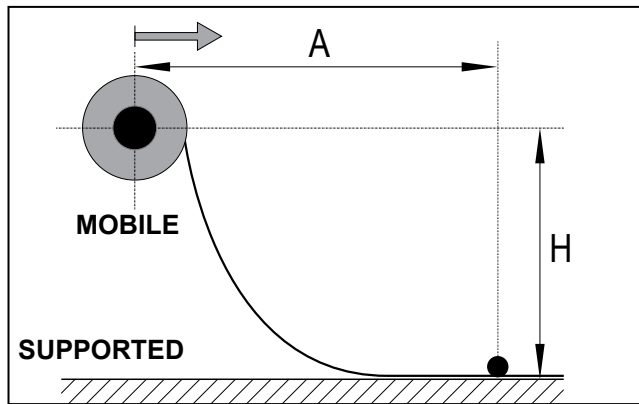

Figure 4 Retrieve Application

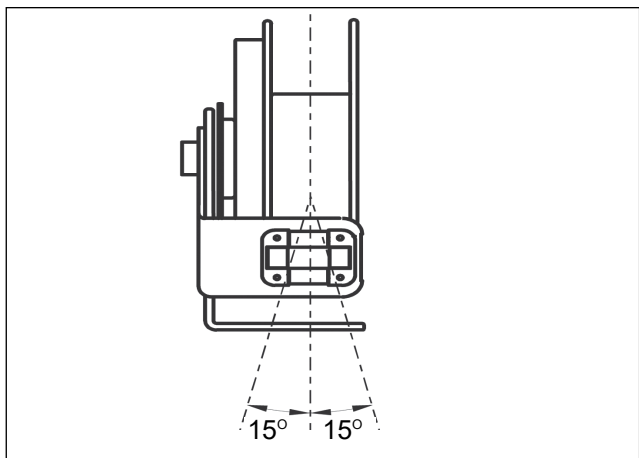

Figure 5 Cable Deflection with Roller Guide

Pivot Base Mounting (Optional Accessory)

All 1200 Series Cable Reels can be furnished with a pivot base to allow the reel to rotate and keep the extended cable perpendicular to the application. See Figure 6.

The PVB Pivot Base will rotate up to 345°. Travel can be limited to 90°, 180°, or 270° by installing an additional roll pin in the appropriate available hole.

A pivot base is required for carousel or loop track applications.

When a pivot base is used the reel must be mounted horizontally ("ceiling" or "floor" mounted).

The Roller Guide should be mounted to require the cable to travel perpendicular to the axis of rotation. This will guard against cable twisting and ensure effective swivel action from the pivot base.

Roller Guides

All 1200 Series units are equipped with a roller guide. The guide's function is to center the cable on the spool and to help the reel wrap cable more evenly. See Figure 7.

The cable should not bear against either end of the spool during winding as this will tend to inhibit level winding of the cable.

The guide should be secured at the best of twelve possible positions so that a minimum change of direction occurs at the guide; otherwise, cable life will be reduced.

A max 15° angle from guide arm center to cable pay out from reel is suggested.

The guide arm is shipped attached to the reel. The guide must be located and secured in the most appropriate position with the 5/16-18 x 5/8" hex head screw and lock washer provided, prior to making any electrical connections.

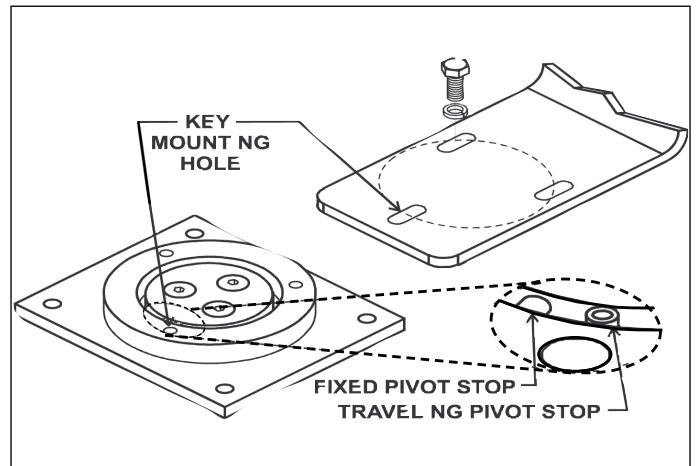

Figure 6

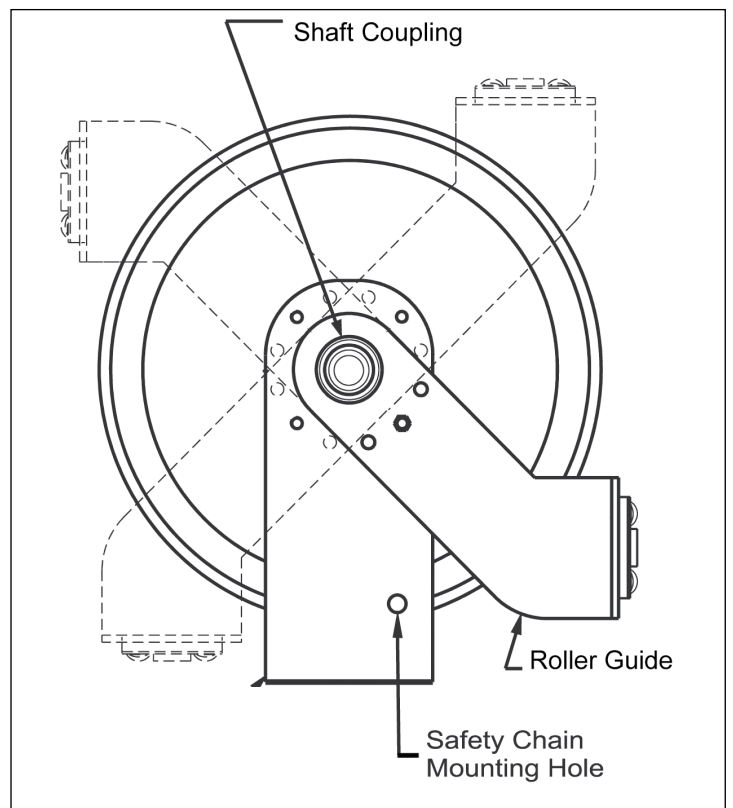

Figure 7 Roller Guide Locations
(4 of 12 possible positions shown)

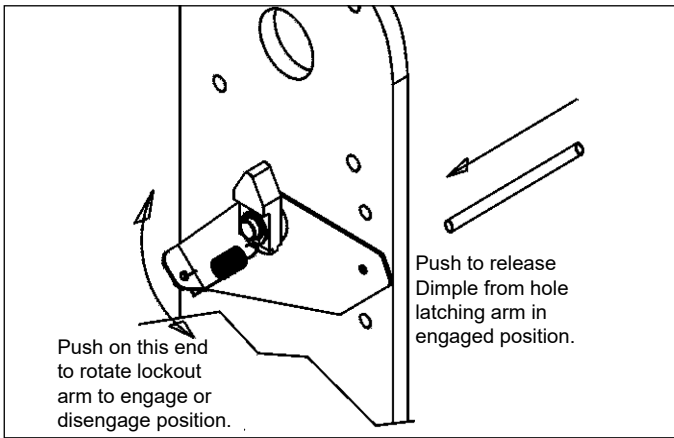

Figure 8

RATCHET

Ratchet Lock

The ratchet lock can be engaged or disengaged, depending upon the application. Reels are sent from factory with ratchet lock engaged. See Figure 8.

Operation with Ratchet

The ratchet pawl is spring loaded. It is designed to function in all acceptable mounting configurations. See Figure 8.

A slight pull on cable will disengage the ratchet. See Figure 8.

Operation without Ratchet

Disengage the ratchet by pivoting the lock-out bar to the lower position. This will remove the ratchet pawl from the path of the ratchet plate. Locate the dimple on the lock-out bar in the hole provided. See Figure 8.

WARNING: Do not engage the ratchet abruptly. Sudden engagement may cause excessive shock loads to the ratchet pawl.

Spring Tension Adjustment

To assure that the cable will retract properly and operate under the correct tension, the reel should be tested.

1. Install cable on drum but do not connect the free end of cable. Securely mount reel before testing.
2. Pull the cable out approximately 20 - 30 feet and allow it to rewind. This procedure should be repeated 5 to 10 times in order to set the spring.
3. Walk the cable back to the reel during the spring tension adjusting process.

WARNING: Do not allow cable to retract without restraining the retraction speed. Always maintain two full cable wraps on drum at maximum cable extension, size cable accordingly.

4. With all the cable wound on the reel, grasp the end of the cable and rotate the drum and cable together in a clockwise direction in order to pre-tension the spring. Generally, one full turn is adequate for most applications. Use no more than two full turns for pre-tension. See Figure 9.
5. Feed the end of the cable through the cable guide and pull the cable out the required length.

NOTE: The number of spool revolutions including the pre-tension turns should not exceed 26 full turns on models with K Spring Motor (see spring motor chart) or 30 turns on models with G Spring Motor. Consult factory or your representative if number of spool turns are not within parameter.

6. Repeat steps if necessary to add or decrease tension. See Figure 9.

NOTE: All reels with factory installed cable have one full pre-wrap on the reel, but has not had the spring tension adjustment process completed.

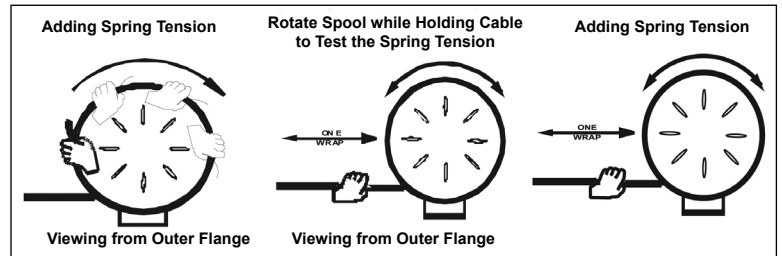

Figure 9

OPERATION INSTRUCTIONS

- Do not exceed the voltage or ampere rating of the reel. Overheating, fire, damage to equipment or personal injury could result.
- Do not allow cable to retract without restraining the retraction speed.
- Operate the reel within the cable size and length and spring tensioning limits for which it was intended.
- Two wraps of cable should remain on the reel at maximum extension to avoid excessive tension on the cable entrance watertight.
- The spring should not be wound to its last two turns at maximum payout to avoid over-stressing the spring, thus reducing its life or damaging the reel.
- Keep the reel and cable clean to avoid excessive wear and damage.
- Arrange for maintenance service if damage is found on the cable or reel.
- Cable should be fully retracted when not in service to maximize spring life.

MAINTENANCE INSTRUCTIONS

Be sure the power is off for all maintenance.

Lubrication

- All springs and bearings are lubricated for life at the factory. Additional lubrication should not be required.
- Do not apply any lubricants or solvent cleaning agents to slip ring, brush or insulator surfaces.

Inspections

- Periodically check the reel for any loose or missing fasteners. Tighten or replace as necessary.

NOTE: Do not over tighten, this will cause fasteners to snap.

- The slip ring assembly should be checked periodically as follows:
 - Clean to remove dust and dirt from the slip ring housing area and all slip ring assembly and brush surfaces.
 - Inspect cable for damage or wear which would make it unsafe to use.

SPRING MOTOR SELECTION CHART

Cable Type	Cable Lengths That Use This Spring Motor	Spring Motor Part Number (Spring)
14/3 SJEOW-A	Up to 50'	G50
12/3 SJOW-A	Up to 50'	K50
14/4 SJEOW-A	Up to 50'	G50
12/4 SJOW-A	Up to 40'	K50
16/3 SOW-A	Up to 50'	G50
14/3 SOW-A	Up to 40'	K50
12/3 SOW-A	Up to 30'	K50
16/4 SOW-A	Up to 50'	K50
14/4 SOW-A	Up to 35'	K50
12/4 SOW-A	Up to 25'	K50

TROUBLESHOOTING INSTRUCTIONS

PROBLEM	POSSIBLE CAUSE	SOLUTION
Reel will not retract cable but has some tension	<ol style="list-style-type: none"> 1) Improper pretension 2) Incorrect reel for application (lift vs. stretch) 3) Cable guide adjustment 	<ol style="list-style-type: none"> 1) See Spring Tension Adjustment 2) Verify Application vs. reel selection 3) Check guide alignment
Reel does not have any spring tension	<ol style="list-style-type: none"> 1) Broken spring 	<ol style="list-style-type: none"> 1) Verify application and duty cycle
Ratchet will not activate	<ol style="list-style-type: none"> 1) Broken ratchet pawl spring 2) Lock-out option arm deactivated 	<ol style="list-style-type: none"> 1) Replace device 2) Activate lock-out arm
Ratchet will not deactivate	<ol style="list-style-type: none"> 1) Over-extension of reel 	<ol style="list-style-type: none"> 1) Manually rotate reel spool to deactivate ratchet. Do not over-extend. (Guide adjustment may prevent lock-up when over-extended)
Cable wraps improperly (uneven wrapping, wraps above or jumps flange)	<ol style="list-style-type: none"> 1) Reel mounting not level 2) Cable retraction rate too high 3) Cable guide out of adjustment 	<ol style="list-style-type: none"> 1) Mount reel on level surface 2) Maintain steady retraction rate 3) Properly adjust cable guide
Cable twisting or knotting	<ol style="list-style-type: none"> 1) Cable rubbing on or bending around fixed object 2) Excessive spring tension 3) Inadequate anchoring of cable 	<ol style="list-style-type: none"> 1) Check roller guide for function and cable payout path 2) Verify application vs. reel selection. Also check pretension 3) Adjust anchoring method i.e. and strain relief
Open or intermittent circuit	<ol style="list-style-type: none"> 1) Inadequate connection 2) Loss of brush contact to slip ring 3) Cable defective 	<ol style="list-style-type: none"> 1) Check all termination points 2) Check brush wear, spring tension & alignment 3) Perform continuity check on cable termination points
Circuit trips and/or pitted burned rings or brushes	<ol style="list-style-type: none"> 1) Inadequate amp rating of reel selection 	<ol style="list-style-type: none"> 1) Verify application requirements vs. reel & cable rating
Circuit arcing	<ol style="list-style-type: none"> 1) Amp or voltage above rating of reel 2) Excessive carbon dust accumulation 3) Water or moisture in slip ring 4) Loss of brush to ring contact 	<ol style="list-style-type: none"> 1) Verify application requirements vs. reel & cable rating 2) Clean dust from inside slip ring 3) Check gasket seal 4) Replace device