

DUAL TECHNOLOGY WALL SWITCH OCCUPANCY SENSORS

LMDW-100 SERIES

Dual Technology sensor with control button(s) to switch or dim selected load(s)

Component of Digital Lighting Management integrated control system

Quick access to Push n' Learn for system personalization



Digital sensor with LCD display and programming pushbuttons

IR transceiver for wireless configuration and remote control

Plug to other components using Cat 5e cables with RJ45 connectors eliminating wiring errors



Description

LMDW-100 Series Digital Dual Technology Wall Switch Occupancy Sensors use PIR and ultrasonic technology to detect occupancy for energy-efficient control of lighting and plug loads. They also include one or two switch buttons for manual control of selected loads, and are part of a Wattstopper Digital Lighting Management (DLM) system.

Operation

LMDW-100 Series sensors operate on Class 2 power supplied to a DLM local network by one or more DLM room controllers. They work with the room controller(s) to control loads based on occupancy. Default operation is automatically established by Plug n' Go, which recognizes the device as both an occupancy sensor and a switch. The sensor and switch button functionality and load assignments will be the same as stand-alone sensors and switches. A system with one load defaults to manual-on, while a system with two or more loads defaults to auto-on for load 1 and manual on for other loads. Initially, all occupancy sensors control all loads, and all switches provide multi-way control of all loads. Two-button units can be programmed so that one button raises the level of a dimmed load, and the other button lowers the level.

Features

- Plug n' Go™ automatic configuration for quick installation and maximum energy savings
- Push n' Learn™ functionality for customization without the need for tools or a PC
- Infrared (IR) transceiver for wireless configuration and control
- Sleek single gang devices fit decorator wall plates; 1- and 2-button models; six color options
- Sensors may be used for multi-way control
- Each switch button can control individual or multiple loads, or one scene; LED indicates status
- Each switch button can be used to raise or lower load levels
- Detection Signature Processing eliminates false triggers and provides immunity to RFI and EMI
- Sensor coverage tested to NEMA Guide Publication WD 7-2000
- This product meets the materials restrictions of RoHS
- BAA/TAA-compliant models available

Digital Settings and IR Communications

LMDW-100 Series sensors may be reconfigured at the device with easy-to-use pushbuttons, or via the LMCT-100-2 wireless configuration tool that communicates with the sensor using a bi-directional infrared (IR) signal. Each sensor is equipped with a unique, easy-to-access, scrolling LCD screen that displays sensor parameters and simplifies changing those parameters. Time delay and sensitivity can be precisely adjusted and walk through mode can be activated. The LCD display also facilitates system personalization, scrolling load information when in Push n' Learn mode. Both load assignments and load parameters may be changed using Push n' Learn. Additionally, each sensor includes an IR transceiver that allows wireless system operation in addition to configuration.

Applications

Wattstopper's dual technology has the flexibility to work in a variety of applications where one technology alone may not be sufficient. Common LMDW-100 Series sensor applications include small private offices, executive offices, small and medium conference rooms and lunch/break rooms.

PROJECT		LOCATION/ TYPE	
---------	--	-------------------	--

Specifications

- Input voltage: 24VDC from DLM network
- Current consumption: 20mA
- DLM local network connection: 2 RJ45 ports
- 1 or 2 switch buttons, each with LED status indicator
- Scrolling LCD display and pushbuttons for setting sensor and system parameters
- Infrared (IR) transceiver
- Operating conditions: for indoor use only; 32-131°F (0-55°C); 5-95% RH, non-condensing
- UL and cUL listed
- FCC part 15 compliant
- Five year warranty

Controls & Settings

Product Controls, Models and Sensor Settings

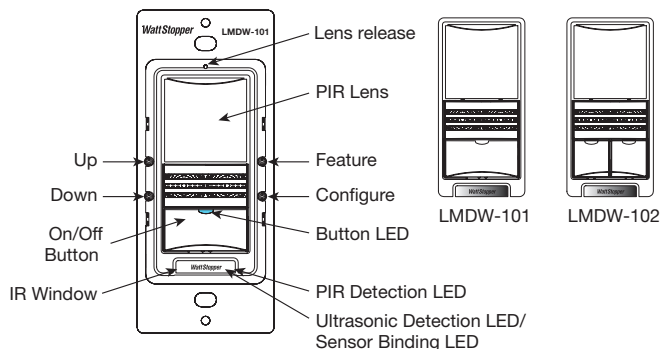

Sensor Parameter	Available Options	Default Setting
Time Delay	1-30 min. (1 min. increments)/Override	20 minutes
Walk Thru	On/Off	Off
PIR Sensitivity	10-100% (10% increments)/Off	90%
Ultrasonic Sensitivity	10-100% (10% increments)/Off	70%
Test Mode	Activate	Off
Detection Technology	Ultrasonic/PIR/Both/Either	Both
Retrigger Technology	Ultrasonic/PIR/Both/Either	Either

Coverage & Mounting

Coverage Patterns

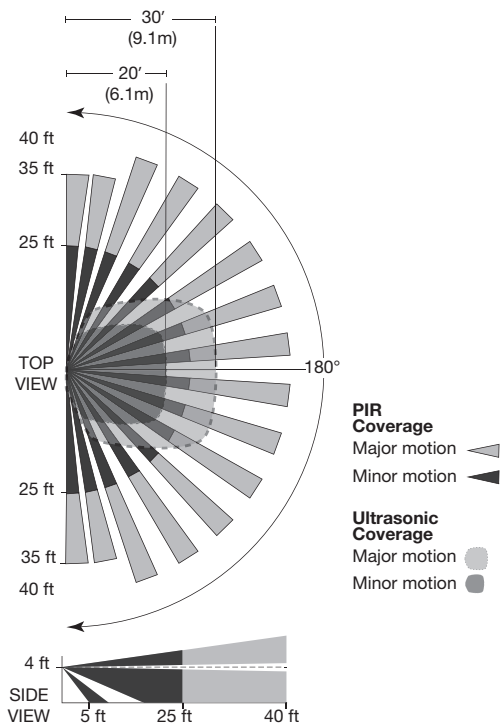

Product Dimensions and Mounting

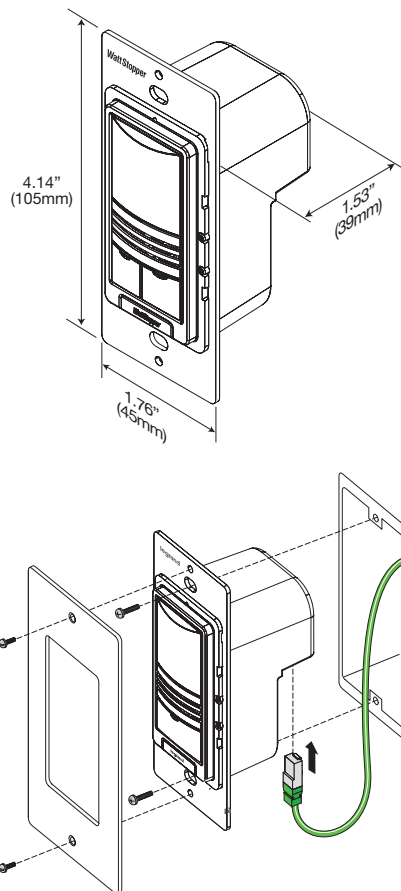

LMDW-100 Series Wall Switch Occupancy Sensors fit in standard gang boxes, or in a four square box with a one or two gang mud ring.

Wiring

Sample Connection Diagram

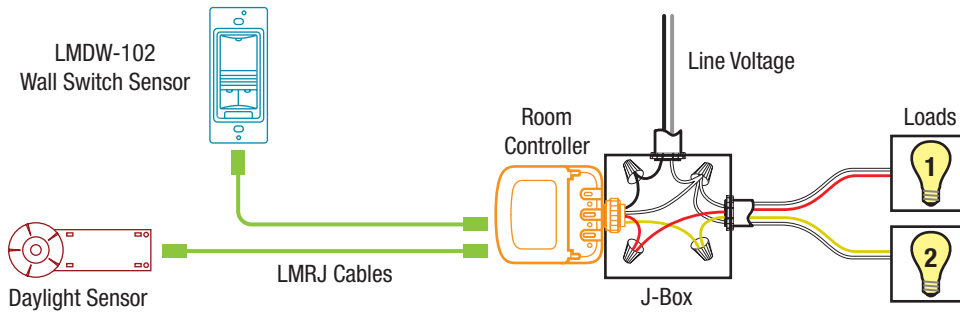

Plug DLM local network components together in any configuration using Cat 5e cables with RJ45 connectors.

Ordering Information

Catalog #	Color	Description
<input type="checkbox"/> LMDW-101-W	White	1-button Digital Dual Technology Wall Switch Occupancy Sensor
<input type="checkbox"/> LMDW-101-LA	Light Almond	
<input type="checkbox"/> LMDW-101-I	Ivory	
<input type="checkbox"/> LMDW-101-G	Gray	
<input type="checkbox"/> LMDW-101-B	Black	
<input type="checkbox"/> LMDW-101-R	Red	
<input type="checkbox"/> LMDW-101-W-U	White	1-button Digital Dual Technology Wall Switch Occupancy Sensor, BAA/TAA compliant*
<input type="checkbox"/> LMDW-101-I-U	Ivory	
<input type="checkbox"/> LMCT-100-2		Digital Wireless Configuration Tool

Catalog #	Color	Description
<input type="checkbox"/> LMDW-102-W	White	2-button Digital Dual Technology Wall Switch Occupancy Sensor
<input type="checkbox"/> LMDW-102-LA	Light Almond	
<input type="checkbox"/> LMDW-102-I	Ivory	
<input type="checkbox"/> LMDW-102-G	Gray	
<input type="checkbox"/> LMDW-102-B	Black	
<input type="checkbox"/> LMDW-102-R	Red	
<input type="checkbox"/> LMDW-102-W-U	White	2-button Digital Dual Technology Wall Switch Occupancy Sensor, BAA/TAA compliant*
<input type="checkbox"/> LMDW-102-I-U	Ivory	

*Product is compliant with Buy American Act and Trade Agreements Act

Wall switch sensors do not include face plates. Order decorator style plate separately.