

Issue: #SB121
Date: February 10, 2009
Topic: Bi-level Sensor Control Best Practice Using Manual-On



Manual-on bi-level switching delivers energy savings and CA Title 24 credit

Bi-level lighting control, which involves switching the lamps in lighting fixtures in two groups (for 0/50/100%, or 0/33/66/100%, output), has been required by California's Title 24 energy code for years, but is uncommon in other states. Recent research proves that this control strategy is extremely effective at saving energy when it is coupled with occupancy sensors allowing manual-on control.

Maximize actual energy savings for bi-level lighting with manual-on sensors

The most common bi-level lighting applications with occupancy sensor control use two line voltage switches wired in series with a power pack, as shown in the diagram below. As long as the sensor detects occupancy, the relay supplies power and the loads may be switched on or off individually. After the space is vacated, the lights turn off. In practice, once both loads have been switched on, they often both remain on (and automatically turn back on) whenever the space is occupied. The occupancy sensor saves considerable energy, but bi-level savings may not be fully realized.

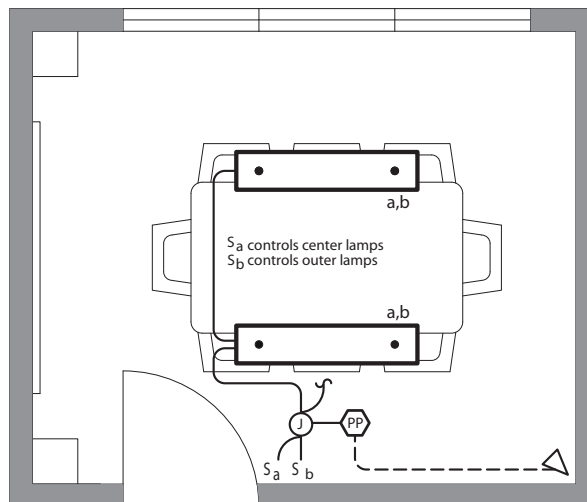

By using an occupancy sensor configured for manual-on control or bi-level automatic-on (just one lighting level comes on automatically when occupancy is detected) **energy savings during occupied periods can be increased to 46-52%**. In fact, bi-level automatic-on provides the highest savings because most occupants seldom turn the second lighting level on. ¹

Section 146 of California's Title 24-2005 allows designers to earn a **20% Lighting Power Density Credit** for employing manual-on or bi-level automatic-on in conjunction with multi-level circuitry and switching in commercial spaces less than or equal to 250 square feet, or in any classroom, corridor, conference room or waiting room, regardless of size.

A simple and cost-effective way to achieve manual-on control or bi-level automatic-on is to specify any Watt Stopper low voltage occupancy sensor along with BZ-150 power packs and DCC2 momentary switches. The BZ-150 power pack has the unique ability to operate either in Auto-On or Manual-On mode simply by flipping a dip switch. The following section illustrates how to wire these products for bi-level auto-on operation; zone A lights (first level) come on automatically upon occupancy and zone B lights (second level) do not come on unless the occupant presses the switch.

Best practice wiring diagram

The best practice control solution for applications, such as the common conference room pictured above, is as follows. The space is controlled by a low voltage ceiling- or corner-mounted occupancy sensor, two BZ-150 power packs and DCC2 low voltage switches for manual control of the two lighting levels, zones A and B.

The BZ-150 wired to the first set of ballasts, zone A, is set to Auto-On. The second BZ-150, wired to the zone B ballasts, is set to Manual-On. When occupancy is detected, only zone A lights come on automatically (the auto-on level could be 50%, 66% or 33% of the lamps). While the space is occupied, either zone may be turned on or off as required. After the space is vacated, the lights turn off.

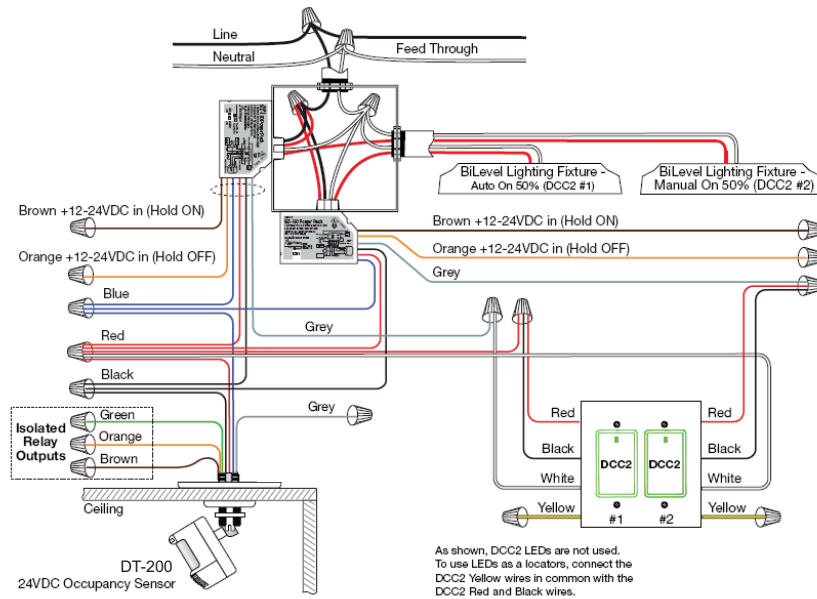

Bill of Materials

Part #	Description	Qty.
	Any Watt Stopper low voltage occupancy sensor	1 or more
BZ-150	Power pack, 120/277V, 50/60Hz, Auto/Manual-On	2
DCC2	Low voltage momentary switch	2

For information on additional control solutions that earn the California Title 24, Section 146, credit, please refer to Watt Stopper Sales Bulletin #SB119.

1. "Bi-Level Switch Study," Pistoichini, Xu and Shira, California Lighting Technology Center, 2008.