



## Walker® Infloor Systems

### 880ADP

Retrofit Kit for 885, 886, 887, and 889;  
Floor Boxes to fit with 893 and 894;  
Floor Box Activation Covers

## INSTALLATION INSTRUCTIONS

Walker® electrical systems conform to and should be properly grounded in compliance with requirements of the current National Electrical Code or codes administered by local authorities.

All electrical products may present a possible shock or fire hazard if improperly installed or used. Walker electrical products bear the mark as UL Listed and/or Classified and should be installed in conformance with current local and/or the National Electrical Code. Look for listing and/or classification mark on product label.

1. Remove existing ring by turning adjusting screws counter-clockwise until ring sub-assembly lifts off floor box.

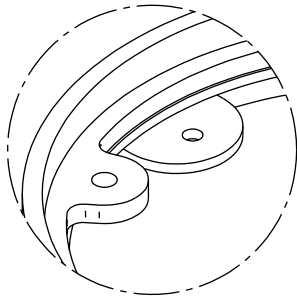

Old Style Ring

2. Replace with new adjusting ring by turning adjusting screws clockwise.

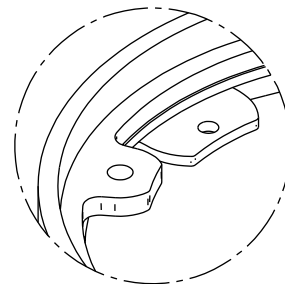

New Style Ring

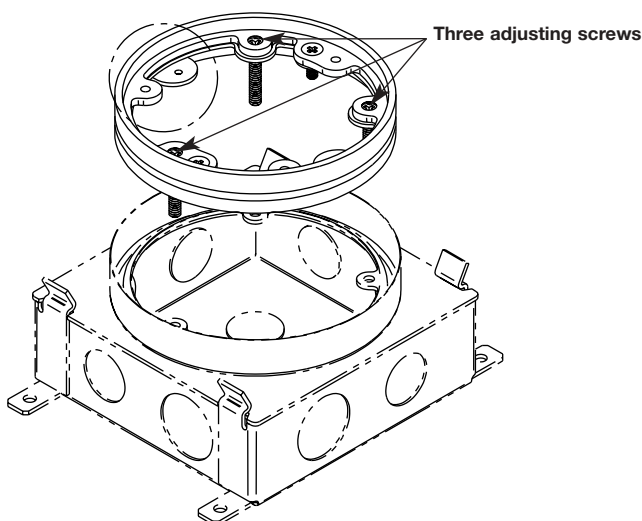

Existing Floor Box in Slab

