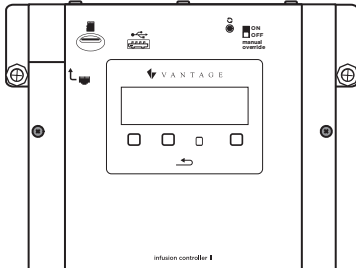

IC-36-II / IC-24-II

Country of Origin: Made in China

OVERVIEW

The InFusion™ Controller II is Vantage's most powerful automation controller to date, featuring a new, extremely fast processor improving processing performance. Systems using the previous InFusion Controller may be upgraded by simply plugging in the new controller,* converting the project file in Design Center 3.3 or 4.X and downloading to the new controller. No changes are needed to the enclosure or the controller terminal board.

* See *Replacing and/or Upgrading InFusion Controllers* later in these instructions for additional information.

FEATURES AND OPERATION OVERVIEW

- The InFusion Controller is the main “CPU” of Vantage's complete systems integration solution
- Plug and Play design makes it easy to install
- Automatic crossover support, RJ45 Ethernet connection
- User Access Management with Design Center 4.X
- Design Center connection through local network or offsite**
 - Firmware updates, full or minor program changes
 - Auto restore of previous firmware and program code if update fails.
 - Diagnostics
 - Read system
 - Project control
- Built-in Ethernet jack
- Type-A, USB port (future features ready)
 - The USB port is not used on IC-II controllers to program from Design Center as in previous InFusion controller models
- System backup via micro-SD card (included)
 - Automatic System Backups to micro-SD card
 - Manually through front panel – real time
 - Within 24 hours of programming system
 - then-
 - Weekly
 - Up to 52 backups total
 - Oldest backup is replaced when 52 limit is reached
 - Backups may be used to program system controllers
- Restore entire system from System Backups
 - Undo option from last Restore
- Power supply is field serviceable
- Ram and Flash memory
- One controller supports up to 120 WireLink™ stations and up to 120 RadioLink™ stations
- Local LCD interface provides status and diagnostics
- Lithium battery retains time and system status in a power outage
- Maintains real and astronomical time clocks
- Design Center software is used to program the Controller
- The Controller runs independent of a PC after initial setup and programming
- Application code is upgradeable through Design Center Software
- InFusion Controllers operate as stand-alone or networked
- Five Embedded RS-232 Ports
- Two RS-485 Ports (shared with SE buses 3 and 4; simultaneous RS-485 and SE bus connections are not possible)
- Manual Override Switch
- Reset Switch
- Built-in Protection, electronic isolation between controllers
- *The Vantage InFusion Controller Network can have up to thirty-one Controllers when connected via Ethernet
 - *15 Controllers maximum on each Controller to Controller Bus run

SPECIFICATIONS

Description	Specification
Dimensions, HWD	6.62" x 7.88" x 3.0" (168mm x 200mm x 76mm)
Weight - 24V	3.55 lbs (1.61 kg)
Weight - 36V	4.4 lbs (2 kg)
Voltage	120-240V, 50/60Hz
Lightning/Surge Protection Station Shock IO. All ports/case	IEC 61000-4-2 Low-voltage, ITU-T K.20
C2C, IC Network	Ethernet
Station Bus Specification	2C, 16AWG / 1.31mm ² , twisted, non-shielded, <30pF per foot. Separate a minimum of 12" / 30.5cm from other parallel communication and/or high-voltage runs
Station Bus Power Supply, IC-36-II	Each Station Bus run has a 60W power supply: <ul style="list-style-type: none"> • Station Bus Run 1 = 60W • Station Bus Run 2 = 60W
Station Bus Power Supply, IC-24-II	Shared, 35W max. power supply combined to both Station Bus runs
Max. Wire Length Station Bus	609m / 2,000ft of cabling max. on each Station Bus. No Station more than 305m / 1,000ft from Controller
Wire Configuration of Station Bus	Daisy Chain, Branch, Star (contact support for Station Bus Best Practices)
Max. # WireLink Stations IC-36-II	Up to 60 Stations each Bus or until the 60W supply per Bus is used
Max. # WireLink Stations IC-24-II	Up to 50 Stations each Bus or until the shared 35W supply is used
Max. Wire From IC to SE	200 feet / 61 meters
Maximum Power Draw IC-36-II	200W
Maximum Power Draw IC-24-II	150W
Cooling	Convection
Lithium Battery Backup	Disk battery CR2032, 3Volt 2.5 yrs. un-powered or 20 yrs. powered (field replaceable – see Caution at end)
System Backup (automatic)	Micro-SD card, included
Ambient Operating Temperature	32-104°F (0-40°C)
Ambient Operating Humidity	5-95% non-condensing
Certifications	UKCA, UL, cUL, CE, EN 55032, EN 55035, EN 61000-3-2, EN 61000-3-3

INFUSION CONTROLLER II PART NUMBERS

Part #	Description
IC-24-II	InFusion Controller 24V V2
IC-36-II	InFusion Controller 36V V2
IC-DIN-II*	InFusion Controller - DIN V2
PSU36-DIN	36V, DIN Controller Power Supply
ACPDXXSM2	24V, DIN Controller Power Supply
IC-PWR-36	IC 36 Power supply replacement for IC-36-II
IC-PWR-24	IC 24 Power supply replacement for IC-24-II

* See **IC-DIN-II Installation Sheet**

**EULA

In order to enhance the security of our products, Legrand ships its products with all insecure ports closed and insecure protocols disabled. You are free to configure your device as needed, but in doing so note that you may be decreasing the security of your device and any information contained in the device. As you modify the device's default settings, keep in mind how this may impact the security of the device and your network. In addition, you should use caution in connecting your device to the Internet, especially if you have altered the default security settings. If you have any questions or concerns about how your modifications of the device may affect its security, please contact the Vantage Controls Tech Support Team at 1-800-555-9891 / www.legrand.us/contact-and-support

SOFTWARE/FIRMWARE/INSTALLATION REQUIREMENTS

Design Center Software, version 3.3.X.X or higher must be used to program controller models with the “-II” at the end of the model number. Using IC-1 and IC-II controller models on the same system, is not supported. Installation of Vantage products should be performed or supervised by a **Certified Vantage Installer**. **Disconnect power when plugging in or un-plugging the controller.** The InFusion Controller is plugged into the Main Enclosure Terminal Board. **This board is different for 24V and 36V controllers.** The Main Enclosure Terminal Board is designed to only accept a Controller that matches the voltage of the card. Make sure the IC is firmly seated before tightening locking screws. Please see **Surface Mount Enclosure for wall box and rack mount options**.

POWERING THE INFUSION CONTROLLER

Use a dedicated breaker to power the IC-II. Maximum power draw by the IC-II is up to 200W for the 36V model or 150W for the 24V model. Multiple InFusion Controllers may share the same breaker when in close proximity.

INFUSION CONTROLLER SETUP IN DESIGN CENTER

Every new project in Design Center automatically includes an InFusion Controller. Additional controllers are added as the project grows, however it is possible to add additional Controllers at anytime.

REPLACING AND/OR UPGRADING INFUSION CONTROLLERS

To convert an existing project from IC-1 to IC-II controllers, open the file in Design Center 3.3* or higher and follow these steps:

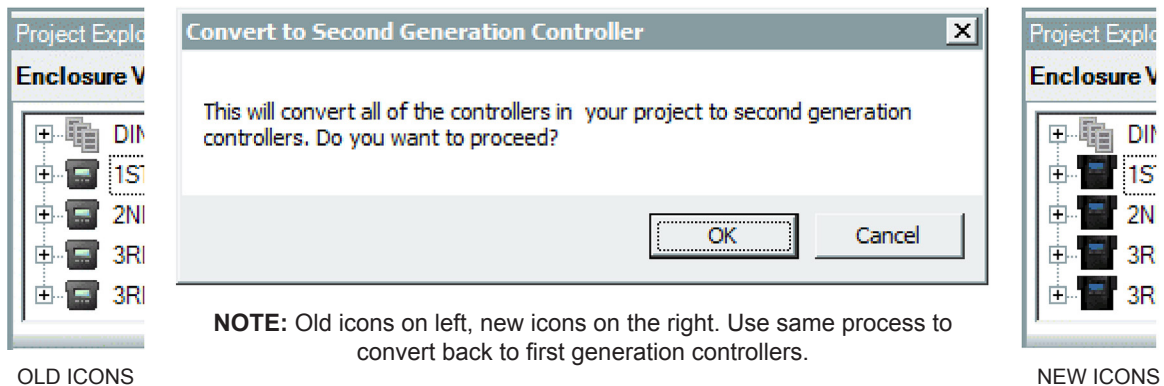

1. Select **Enclosure View** and right click on the first controller and select **Convert to Second Generation Controller**.
2. The message box is opened explaining that all controllers will be converted. Answer **OK**.
3. All of the controllers are then converted to generation II controllers with original programming.

***IMPORTANT STEPS FOR UPGRADING EQUINOX SYSTEMS** - Projects with Equinox devices should do the following:

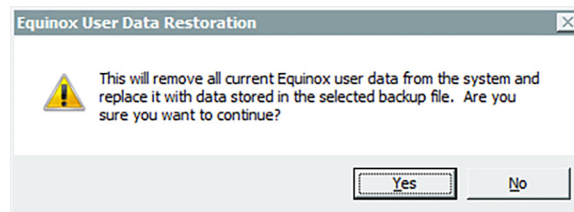

1. Program the system one more time with the old project file **before** replacing the controllers. (Only do this step if the old controllers will accept programming from Design Center)
2. With the newly converted file opened in Design Center, click on **System | Backup and Restore | Restore Equinox Data From Backup**
3. Select the most recent *.EQUD file; answer **Yes** to the question above.
4. Design Center will program the system with the new file and restore Equinox data to new controllers stored in the *.EQUD file.

PROGRAMMING THE INFUSION CONTROLLER

Most programming is created and edited in Design Center software and saved as a project file. Projects are then downloaded to the system controllers via a local or remote connection to the local network.** It is recommended to have one micro-SD flash card per system and that the SD card be placed in the same controller used to connect Design Center (faster).

** See EULA Statement, page 2.

PROGRAM CONTROLLER USING A DIRECT CONNECTION FROM COMPUTER

If the controller is not connected to the local network, it is possible to program the controller by connecting the computer directly to the controller via an Ethernet cable – standard or cross-over type.

- Set the controller IP address to Default 192.168.0.<controller number>
- Set the computer's IP address to 192.168.0.40 or similar

(NOTE: USB connection between Design Center and IC-II controllers is not supported)

UPDATING FIRMWARE ON THE CONTROLLER FROM 3.9 TO 4.X

These steps provide information on updating your controller's firmware with Design Center 4.X and enabling User Access Management.

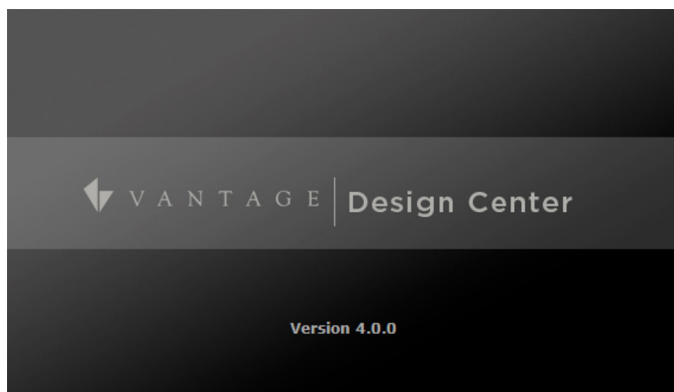

1. Make sure that you are using Design Center 4.X and verify the IP address of your InFusion Controller. Open the Connection, IP Address field and enter in the IP address of your controller. You can also use the pull down field to find and select your controller by IP address.

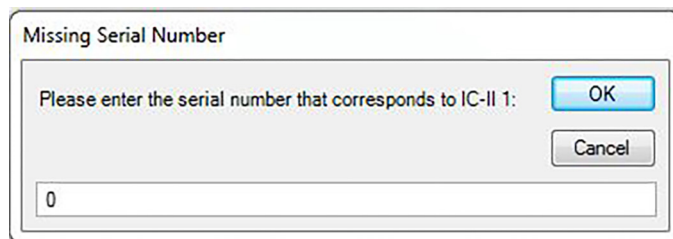

2. Go to **System: Update Firmware** and select **Update Controller Firmware**. You will receive a **Missing Serial Number** window. Enter in the serial number of your InFusion Controller and select **OK**. If you have multiple controllers, write down each of the InFusion Controller serial numbers for reference.

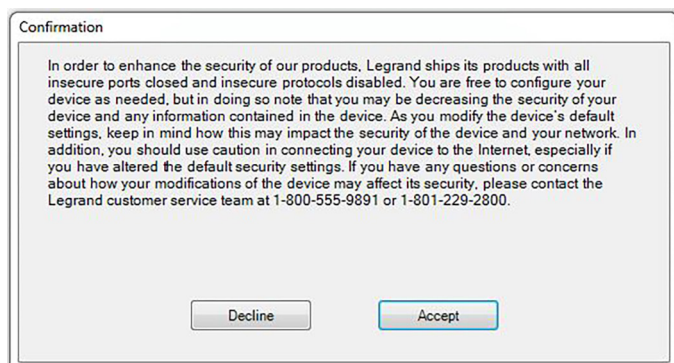

3. A confirmation window will appear. Please review the EULA and select **Decline** to end the update process or **Accept** to continue with the firmware update.

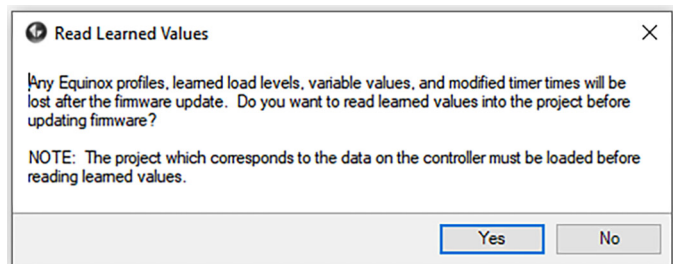

4. Next, the **Read Learned Levels** window will appear. If you are upgrading an existing site and need to retain Equinox profiles, learned load levels, etc., select the **Yes** box. If this is a new site and you do not need to retain Equinox profiles, learned load levels, etc., select **No** to proceed.

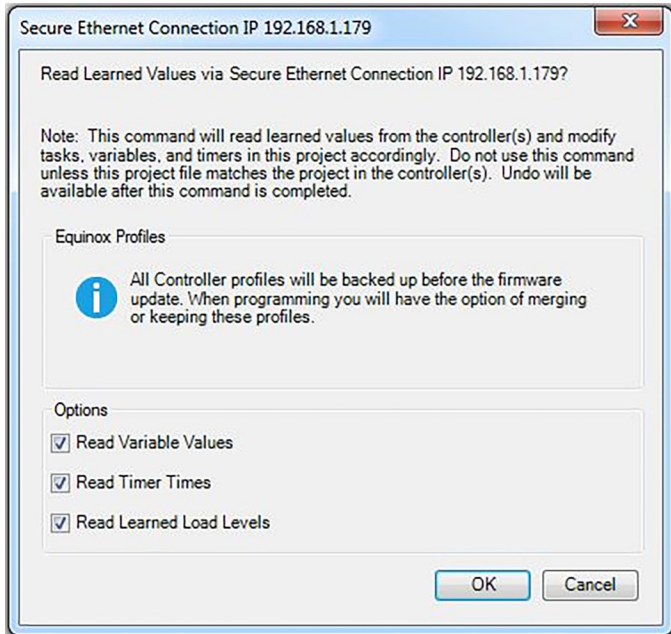

5. You will see a yellow Vantage icon in the upper menu as Design Center is connected to the InFusion Controller. If you selected Yes from the previous step, the **Secure Ethernet Connection** window will appear. Select the options that you would like to retain while updating the controller firmware. Select **OK** to proceed.

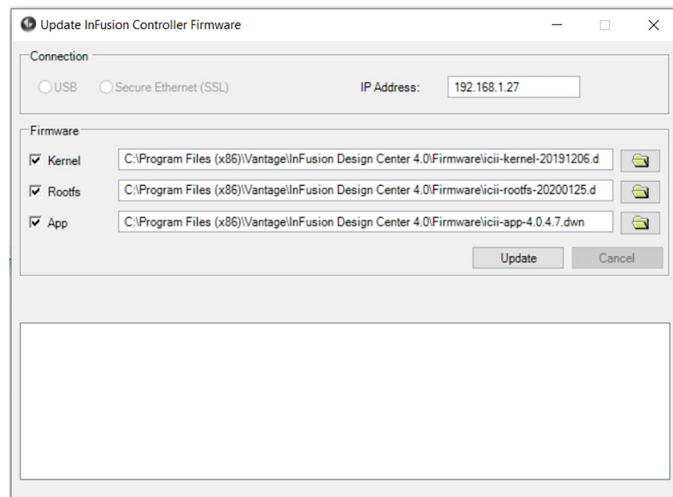

6. Inside the **Update InFusion Controller Firmware** window, check the boxes next to the Kernel, Rootfs, and App so that each of these will all be updated together. This is required when moving to Design Center 4.X from any previous versions. Select **Update** to continue.

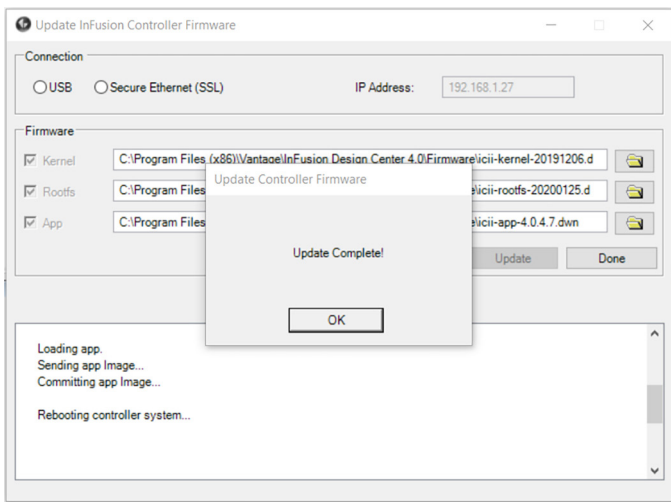

7. After this process is complete, User Access Management will now be enabled on the controller. Select **OK** on the **Update Complete!** box. Using the front LCD on the InFusion Controller, verify that the firmware version has updated.

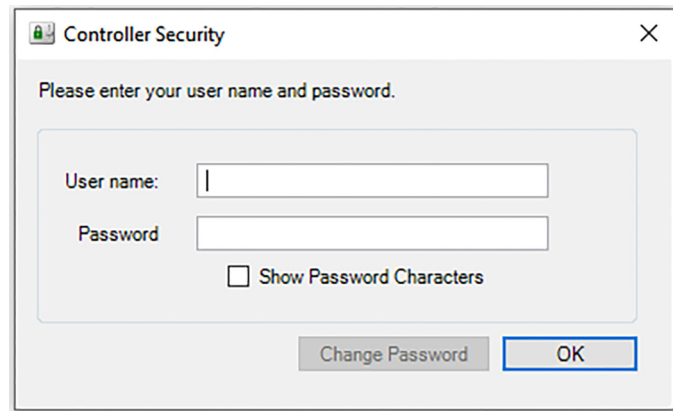

8. Next you will need to program the InFusion Controller and create a new password. Select the **Program Icon** (F5). A **Controller Security** window will appear. The default username is *administrator* and the default password is the controller serial number. Check the **Show Password Characters** to verify your serial number. Select **OK** to move to the next step in the update process.

UPDATING FIRMWARE ON THE CONTROLLER FROM 3.9 TO 4.X *(continued)*



9. Create a new password in the **Update Default Password** dialog box. Verify the accuracy by checking the **Show Password Characters**, then click **OK**. In the next window select the Equinox, Program, and Read and Restore options you would like to retain. Next, select **OK** to program the InFusion Controller.

RESETTING THE CONTROLLER PASSWORD THROUGH THE CONTROLLER

If you need to change the password through the controller or forgot your password in 4.X, follow these simple steps.



1. From the front of your controller, press any button. Select **Info** at the bottom.

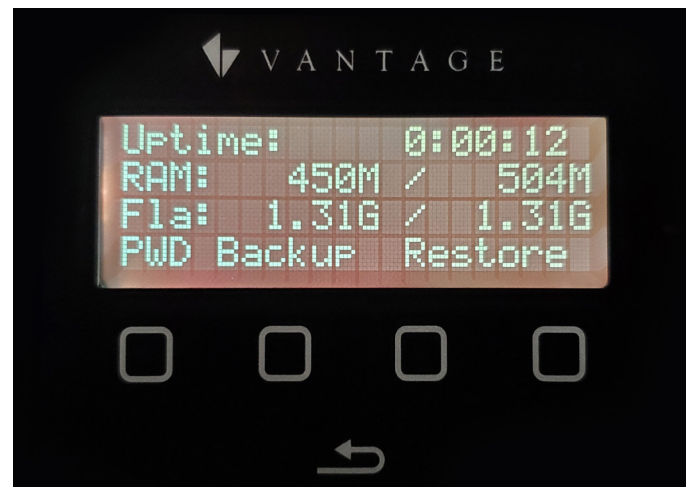

2. On the new screen, press **PWD** at the bottom left for the password.

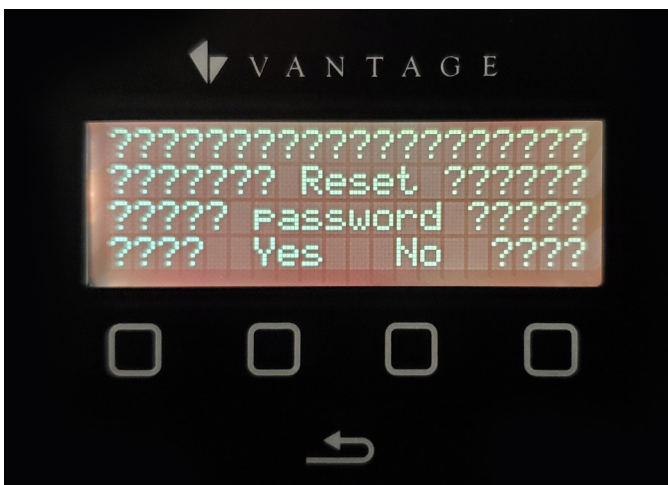

3. Press **Yes** to reset the password.

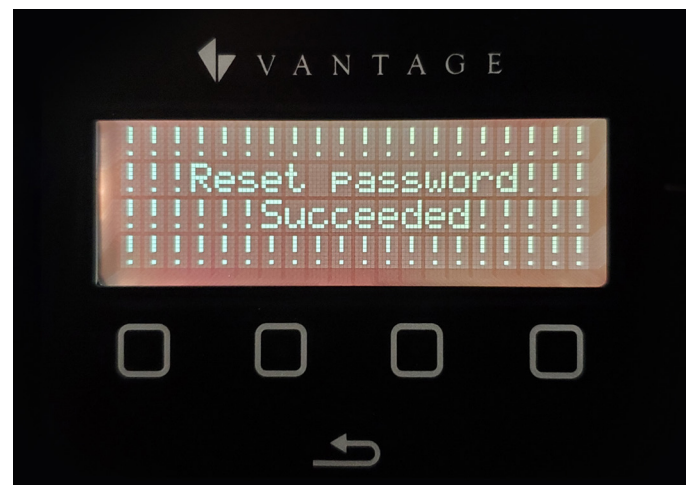

4. A new screen will confirm **Reset password Succeeded!** Tap the exit arrow twice to return to the main screen and exit back out.

RECONNECTING THE CONTROLLER AND DESIGNER CENTER

Review previous steps to recreate user name and password in Design Center.

REVERTING FIRMWARE ON THE CONTROLLER FROM 4.X TO PREVIOUS VERSIONS

Reverting to older firmware may be necessary to keep your system running during a 4.X beta trial. Follow these steps to revert back to a former version to continue to run the system.

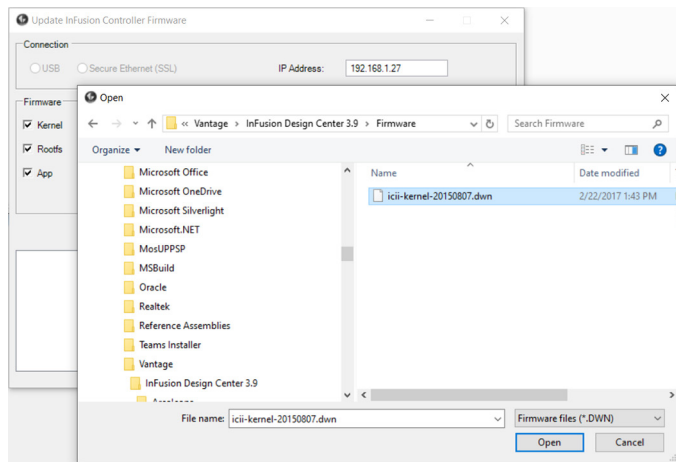

1. Inside the **Update InFusion Controller Firmware** window, check the boxes next to the Kernel, Rootfs, and App so that each of these will all be updated together. **NOTE:** You must select and upload the Kernel, Rootfs, and App together, or else the controller may not recover and may have to be shipped in to be repaired. To select previous versions of these files, browse to the desired firmware file e.g. C Drive: Program Files x86: Vantage: InFusion Design Center 3.9: Firmware and select the correct 3.9 Kernel.

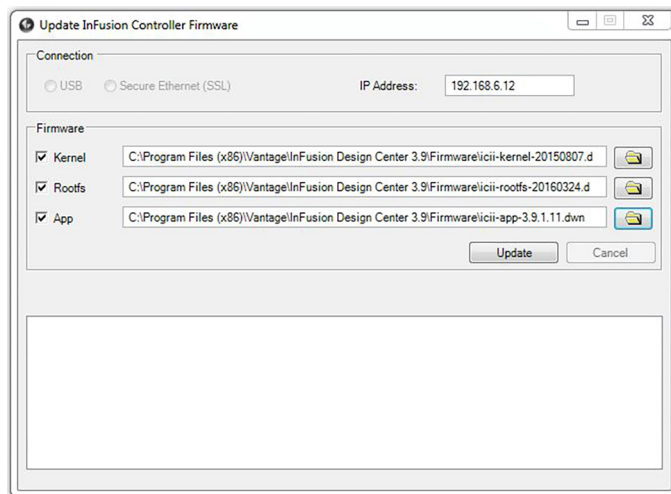

2. Once the Kernel has been selected and opened, it should appear in the Kernel line. Next, click the folder next to Rootfs and Windows will return you to the same folder you previously opened. Select the desired Rootfs file and select **Open**. Repeat this process for the App folder.

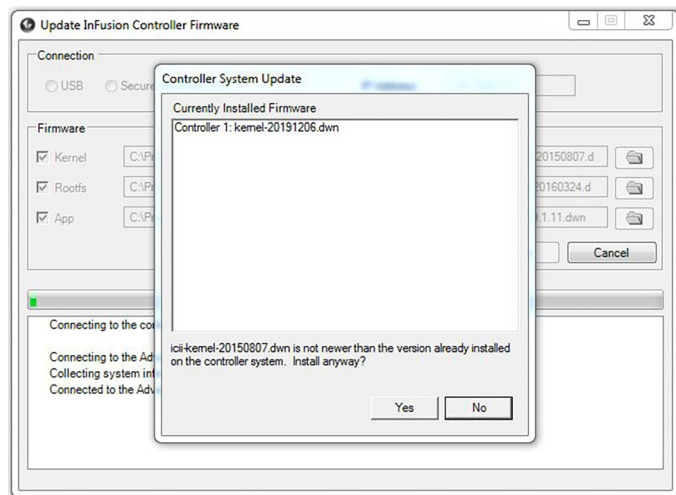

3. Now that the correct Kernel, RootFS, and App versions are selected, click **Update** which will take you back to the previous firmware version. A dialog will ask if you would like to revert to previous firmware version(s). Select **Yes** to the Kernel, Rootfs, and App to continue backdating the controller. When complete, select **OK**.

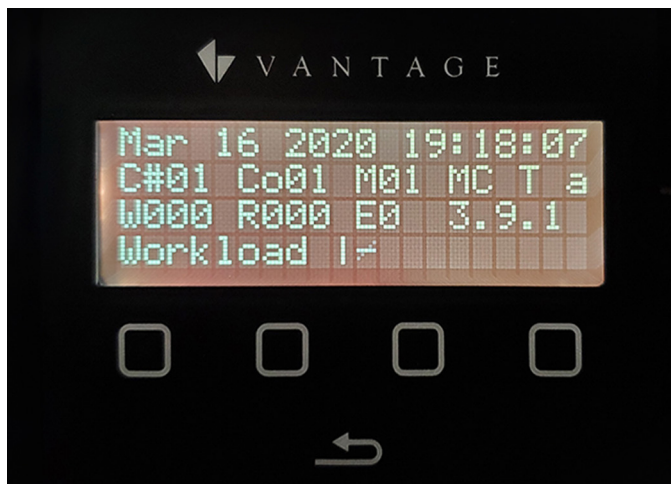

4. You can physically verify on the controller that 3.9.1 (example shown) has been restored.

REMOTE PROGRAMMING AND MAINTENANCE**

Remote programming and update capability may save unnecessary trips to actual sites. With remote updates, care should be taken to ensure that updates are complete and the system's new programming functions properly.

** See EULA Statement, page 2.

REMOTE ACCESS ETHERNET PORT SETTINGS**

- For standard Ethernet connections, forward ports 2001 and 3001 to the IP address of the InFusion Controller
- For Secure Ethernet connections (SSL), forward ports 2010 and 3010 to the IP address of the InFusion Controller
- **When using a static IP address on the controller the gateway must also be setup on the controller**
- Allow the Ping operation – used by Design Center to verify its connection
- In Design Center enter the IP Address of the router or modem assigned from the ISP. Design Center may also require a User Name and Password if User Access Management has been enabled.

** See EULA Statement, page 2.

BACKUP MEMORY VIA MICRO-SD CARD

A micro-SD card slot is provided for program backup and allows automatic backups periodically performed by the controller.

- Stores backup of all programming for project file
- SD cards directly accessed using Design Center Diagnostics
- InFusion System (all Controllers) may be programmed/re-programmed from the SD card connected to any controller without running Design Center or connecting a computer
- Typically, only one micro-SD card is recommended per system
- Replace the existing micro-SD card when inserting an Equinox multiple license micro-SD card

CONTROLLER TO CONTROLLER WIRING

C2C ETHERNET BUS

Today's integrated devices use ever increasing amounts of metadata. For this reason it is recommended to use C2C Ethernet communication between multiple controller systems. Each controller should have its own Ethernet connection to the local network. In turn the local network should have access to the internet. With this type of connection it may be necessary to assign unique Channels from the IC's front panel, in case more than one InFusion Design Center System is on a network (See *Front Buttons | Screen 16* later in this document). With this type of connection InFusion network distances are only limited to the network itself. C2C Ethernet connection must be **Enabled**.

CONTROLLER BUS

When connecting multiple controllers via Controller Bus, Vantage recommends the use of 16-18 AWG 2-conductor, twisted pair, non-shielded wire from IC to IC. *This is a polarized connection* with "+" and "-" screw terminals. The maximum wire length sum for all controllers connected together may be up to 2,000ft. using the above wire specification.

MAIN ENCLOSURE TERMINAL BOARD – TERMINATOR SWITCH

If one InFusion Controller is used, the Controller Bus Termination switch is always **ON**. This switch is located on the Main Enclosure Terminal Board. If multiple Main Enclosures are used **ONLY** the first and last Main Enclosure Terminal Boards on each Bus should have the Controller Bus Termination switch **ON**.

NOTE: Termination switch has no affect on C2C communication.

When updating an existing Vantage system to generation II controllers the existing Controller Bus may be left. However, when possible run Ethernet to each controller on the updated system and enable **C2C Ethernet Bus** communication. The new controller will use the C2C connection as primary and use the Controller Bus as a backup. For additional enclosure wiring information, please see enclosure instructions.

CONNECTING TWO CONTROLLERS VIA FRONT ETHERNET PORT

Two InFusion Controllers may be connected to each other using the Ethernet ports on the front of each Controller. The maximum length of the network cable is 328ft or 100meters. C2C Ethernet connection must be **Enabled** – see InFusion Controller Front Panel Button Operation (below). **NOTE:** This is generally not recommended as the two controllers will not have Internet access when connected this way.

FRONT BUTTONS

Through front panel buttons on the InFusion Controller edit or see, time, IP connection, IC Information and other settings. The Controller may also be placed in service mode from the front controls.

SERVICE MODE

Press and hold **Exit**, press and release **Reset**. Continue holding **Exit** for about 5 seconds, then release. Press **Reset** by itself to exit service mode.

The following contains additional detailed information on some of the LCD screens on front of the controller:

SCREEN 4, IP SETTINGS – A static IP address may be assigned to the IC. Once a static IP address has been assigned to the Controller and saved, the NM: (NetMask) address displays automatically. With the NetMask field highlighted click the **Adj.** button to change settings for NM, GW, DNS1, and DNS2. Adjust each communication protocol as needed. The NM and GW settings are necessary for the controller's internet access and the connection of remote Equinox devices.

SCREEN 6, DHCP – This screen allows the InFusion Controller to obtain an IP address automatically through DHCP. Record this address in the Design Center project file for future connections through Ethernet.

SCREEN 7, CONTROLLER INFORMATION – This screen shows information about the InFusion Controller.

- **Uptime** – the amount of time the IC has been operating without losing power, reported in **days: hours: minutes**.
- **RAM** – Free Memory / Total Memory
 - RAM: This is the active memory, Random Access Memory and is volatile.
- **Flash** – Free Memory / Total Memory
 - Flash memory is nonvolatile like the Hard-Drive on a computer. This is the main memory storage area for all programming. Data is compressed when downloaded.
- **Backup** – System must contain a micro-SD card to create a current backup of the system via the micro-SD card. Answer Yes or No to create or cancel the new backup.
- **Restore*** – System must contain a micro-SD card. Pressing button **3** or **4** will open a screen allowing the selection from a history of backups. Select which backup is wanted with Up/Down buttons and then press **Select**. Answer **Yes** or **No** to execute or abort the restore.

***This will re-program all of the controllers on the system from the selected backup.** When a backup has been manually executed, an **Undo** option appears in the backup history list.

CONTROLLER TO CONTROLLER WIRING

SCREEN 16, C2C SETTINGS – This screen is very important when using IP for controller to controller communication. C2C—Ethernet: (Eth:) must be *Enabled*.

CHANNEL: Because more than one InFusion System may be on a single network a unique channel (Chn:) number may be assigned to the controllers for each InFusion System. The Peer number is assigned automatically. Example, it is possible to have two or more ICs with address 1, address 2, and etc., in a large building containing two or more InFusion systems. These InFusion systems can all be on one network. Assigning a unique channel number to each Controller group allows the identically addressed controllers to operate as independent systems on the same network.

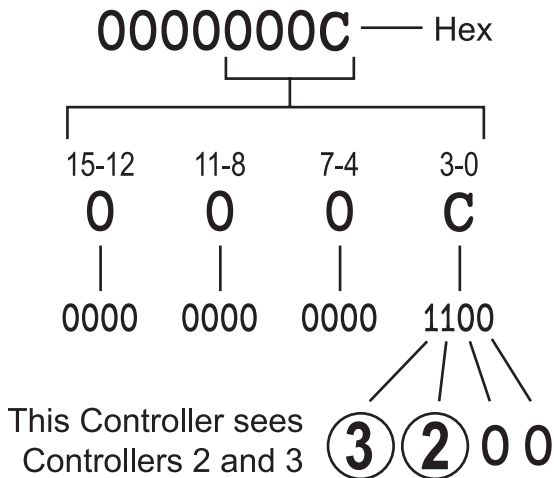

PEERS: This is a bitmask of all controllers visible to this controller displayed in HEX. Convert to binary to see controllers position. Each “1” in binary, is a Controller.

Example: Peers: Channels: –

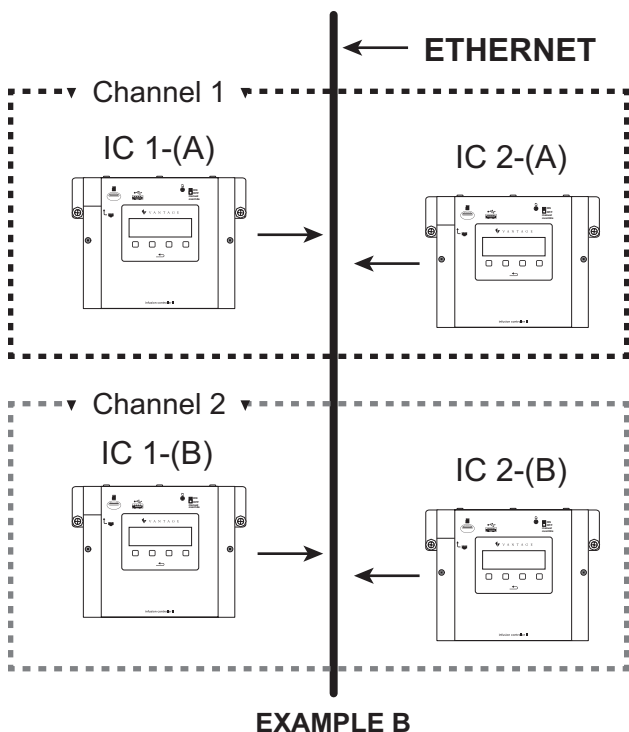

EXAMPLE A: IC 1-A sees both IC 2-A and IC 2-B controllers. It does not know which IC 2 belongs to its network. At the same time IC 1-B also has the same problem.

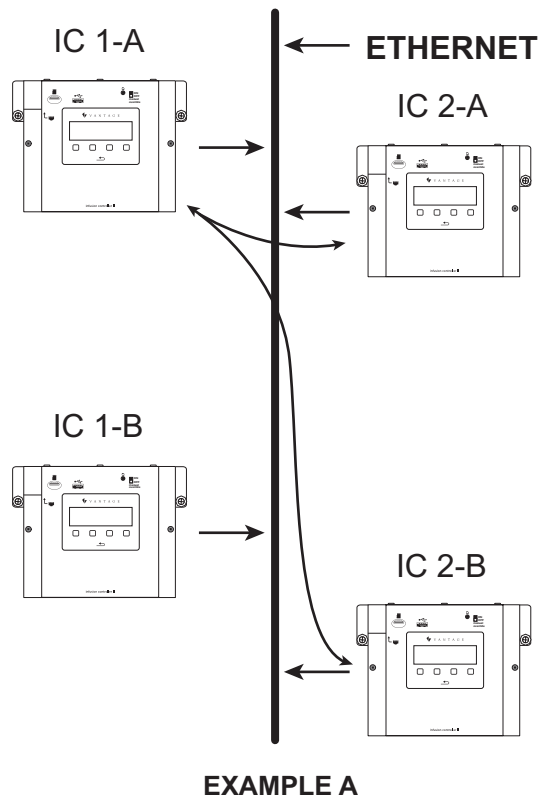

EXAMPLE B: The “A” controllers and the “B” controllers have been assigned channel numbers 1 and 2 respectively:

- Channel 1 for IC 1-A and IC 2-A
- Channel 2 for IC 1 B and IC 2-B

This now allows each controller on the network to only talk to its co-controllers and ignore other controllers.

INFUSION CONTROLLER FRONT PANEL BUTTON OPERATION

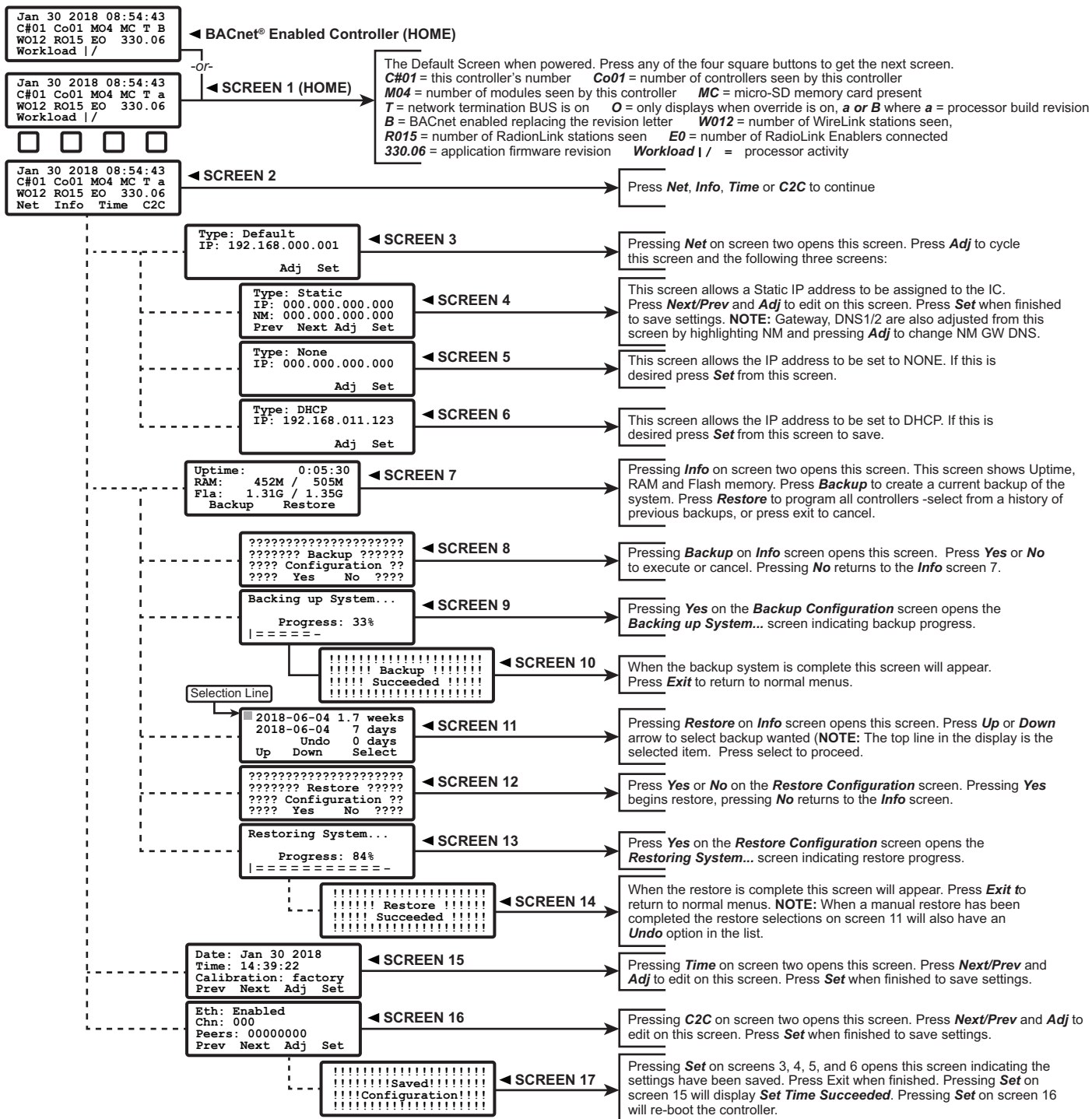

PLACING CONTROLLER IN SERVICE MODE AND SECURITY MODE

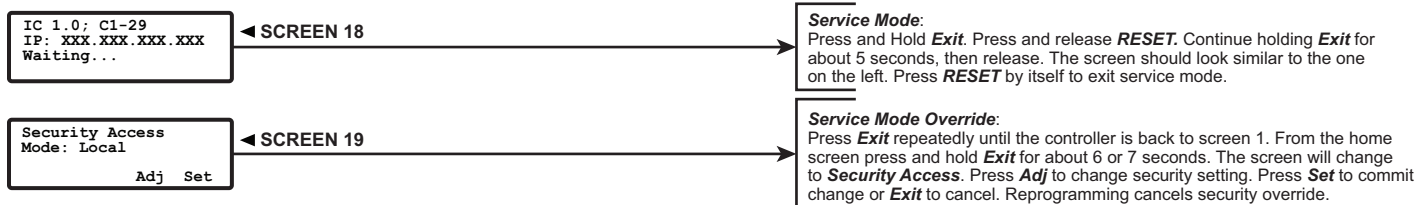

CONTROLLER FIRMWARE/DESIGN CENTER 3.3 AND HIGHER FEATURES

Design Center 3.3 and higher is compatible with IC-1 and IC-II controllers. Many of the 3.3 features are available in both versions of the InFusion Controller.

New Features:

- Backup and Restore
- Enhanced Email Support
- Remote Location Firmware Updater – IC-II only

USER ACCESS LEVELS AND USER'S TABLE

Security Levels	Level Requirements for Groups	
	Admin	User
Remote**	- Credentials required for all remote connections including Design Center	- Credentials required for all remote connections using Host Commands - Connections from Design Center; not allowed
Local	- Credentials required for all local or remote connections including Design Center	- Connections from Design Center; not allowed

** See EULA Statement, page 2.

SETTING UP CONTROLLER/PROJECT USER ACCESS MANAGEMENT

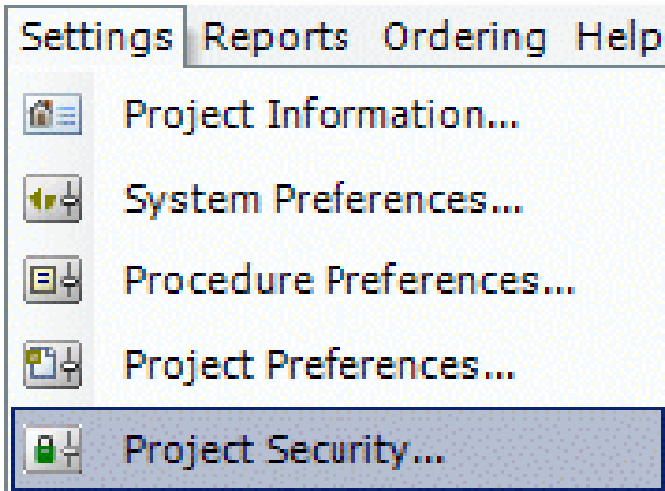

1. By default, project security will be LOCAL when a new project is started.

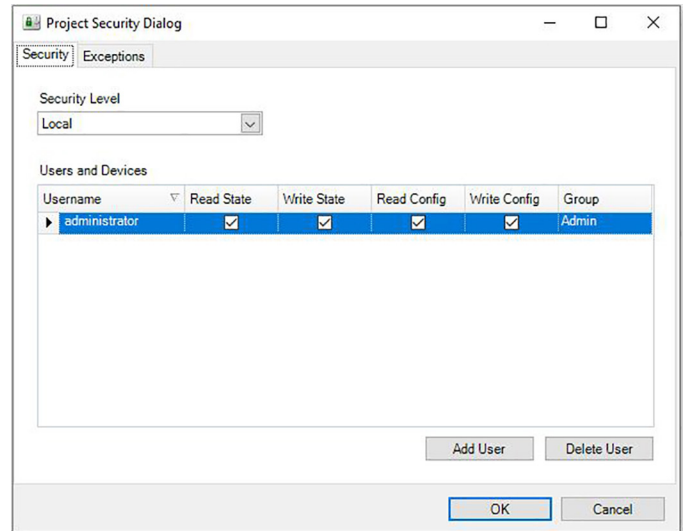

2. To edit **User Access Management** in a new or existing project, click on **Settings** and select **Project Security**. The **Project Security Dialog** opens.

SETTING UP CONTROLLER/PROJECT USER ACCESS MANAGEMENT *(continued)*

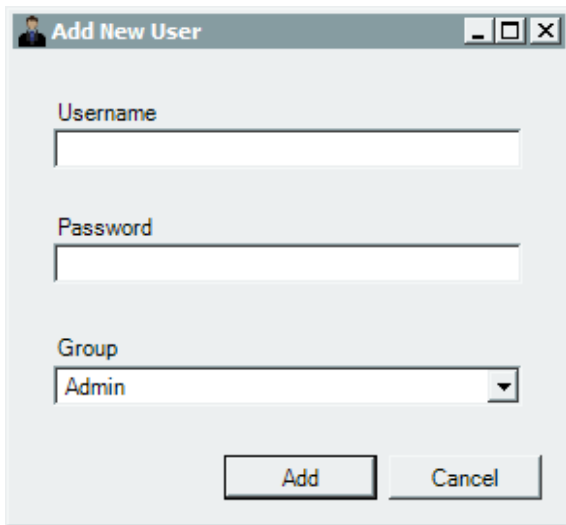

3. To create a user press **Add User**. The **Add New User** dialog box opens. Enter a **Username** and **Password** and select **Admin** or **User** to assign a group. Press **Add** to add the new user.

- **Admin** have all permissions selected by default. **Admin** is required by Design Center with User Access Management enabled.
- **Users** cannot connect to the controller from Design Center. Users only have **Read State** and **Write State** permissions using **Host Commands**.
 - Custom permissions may be selected for either group member type.

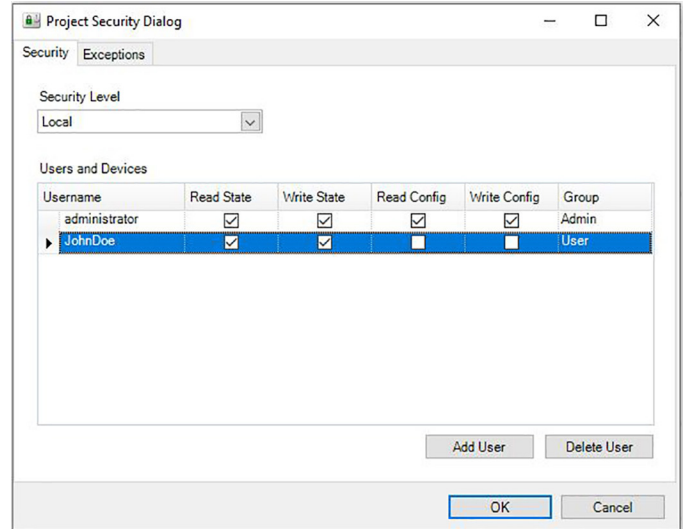

4. The **Remote Access** level requires proper credentials for any remote connection.

5. The **Local Access** level requires proper credentials for local or remote connections – highest security level.

6. The **User Access** setting is sent to the controller when programming or updating the system.

7. All User Access settings are saved with the project.

EXCEPTIONS TO SECURITY

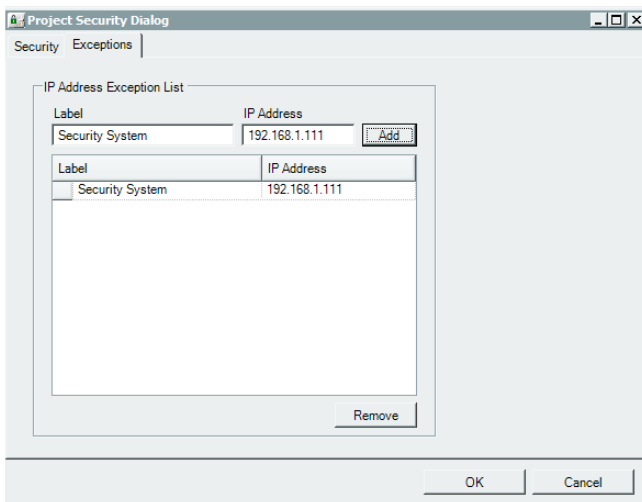

1. IP Address Exception List

If a third party device is not capable of sending a username/password, the IP Address of that device can be entered into the exception list.

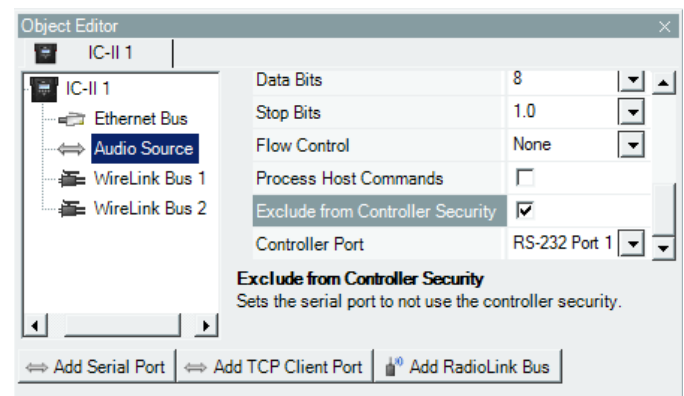

2. Serial Port Exception

If a third party device connected to a serial port is unable to send a username/password, check the **Exclude from Security** checkbox in **Object Editor**.

TEMPORARY SECURITY OVERRIDE**

A Security override feature exists on the controller through the panel buttons on the front of the Controller.

1. From controller press **Exit** until the controller is back to screen 1, the Home page. From the Home page press and hold **Exit** for about 6 seconds – until the screen changes.
2. Press **Adj** to change security setting to **None** or **Remote**. Press **Set** to commit change. The change will be active until system is reprogrammed. Pressing the Exit button without making changes cancels the controller screen without saving changes.
3. **NOTE:** If security has not already been programmed on the controller, adjusting the security setting via the controller buttons does not do anything.

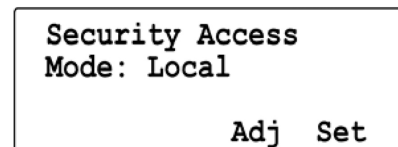

** See EULA Statement, page 2.

BACKUP AND RESTORE

USING BACKUP AND RESTORE

The backup and restore feature requires that one or more controllers on the system contain a micro-SD Card.

- Recommendation: The Controller used to connect Design Center contains the system's micro-SD card.
- Recommendation: Install one micro-SD card per system.

BACKUP AND RESTORE FROM DESIGN CENTER

1. In Design Center click on **System | Backup And Restore** and select from:
 - a. **Full System Backup**
 - b. **Full System Restore**
 - c. **Restore Equinox Data From Backup**
 - **Option "c"**, restores Equinox profile information on controller and opens programming screen.
2. If **Backup** is selected, the system writes the current controller programming to the micro-SD card.
3. If **Restore** is selected, the system opens a selection menu.
 - a. Last Week
 - b. Last Month
 - c. Last Quarter
 - d. User Initiated (only shows when a manual backup operation has been selected)
 - e. Choose Backup by Date
4. **Choose Backup by Date** opens a complete history.

NOTE: These same operations may be performed from the controller via the front panel buttons. See *InFusion Controller Front Panel Button Operation*.

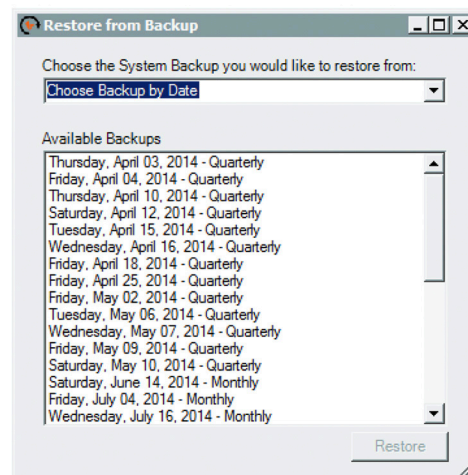
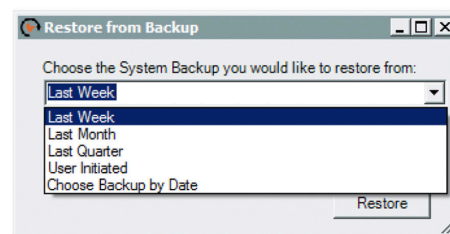

EXPANDED EMAIL OPTIONS

1. Design Center 3.3 and higher comes with new controller firmware containing enhanced email support.
 - a. Gmail
 - b. Yahoo
 - c. Outlook.com
 - d. Other (i.e. aol, etc.)

NOTE: IC-1 and IC-II could differ in email support – IC-1 has a smaller OpenSSL library due to memory restrictions. Test to verify email operation on all email services.

2. In Design Center click on **Settings** and select **Project Information**.
3. In the **Project Information** window, select the **Email** tab to open the email setup window.

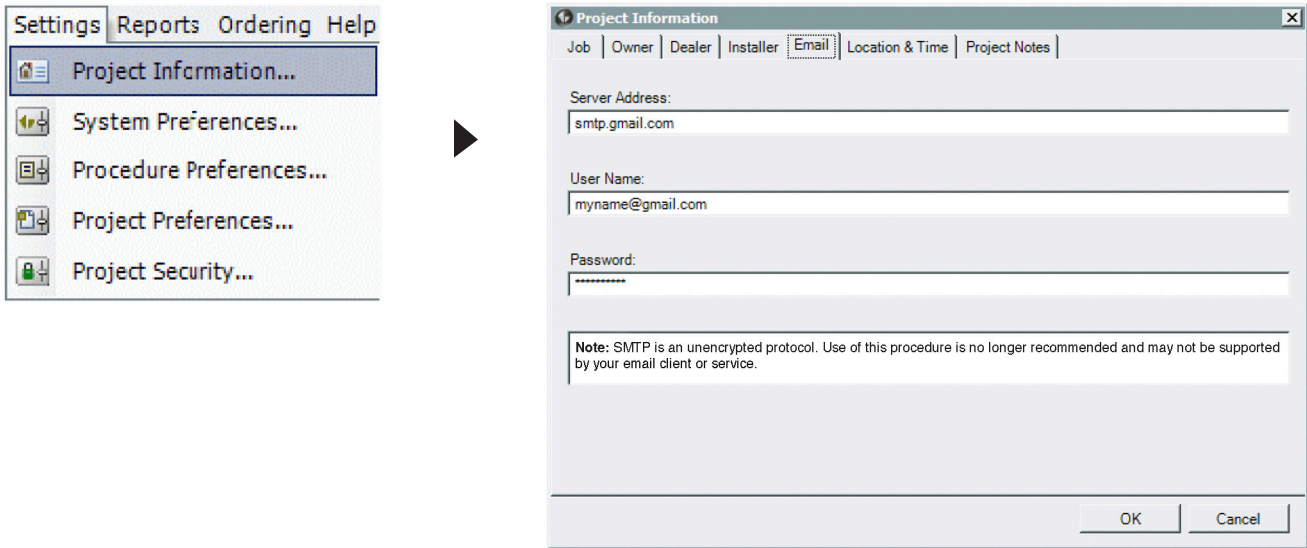

4. The **Server Address** is the SMTP server information, for example, *smtp.gmail.com*. The correct SMTP server information is needed for the Email service being used. Please check with the email service provider for the specific SMTP Server information.
5. The **User Name** is the user name used when setting up an email account, for example, *myname@gmail.com*.
6. Finally the **Password** is the password required to access your email account.
7. Click **OK** when finished.
8. Tasks may be assigned to send emails as part of their execution process. **NOTE:** Email setup in any Design Center project helps the project be future ready for new features.
9. In Design Center select **Communication | Messaging | Send Email**.

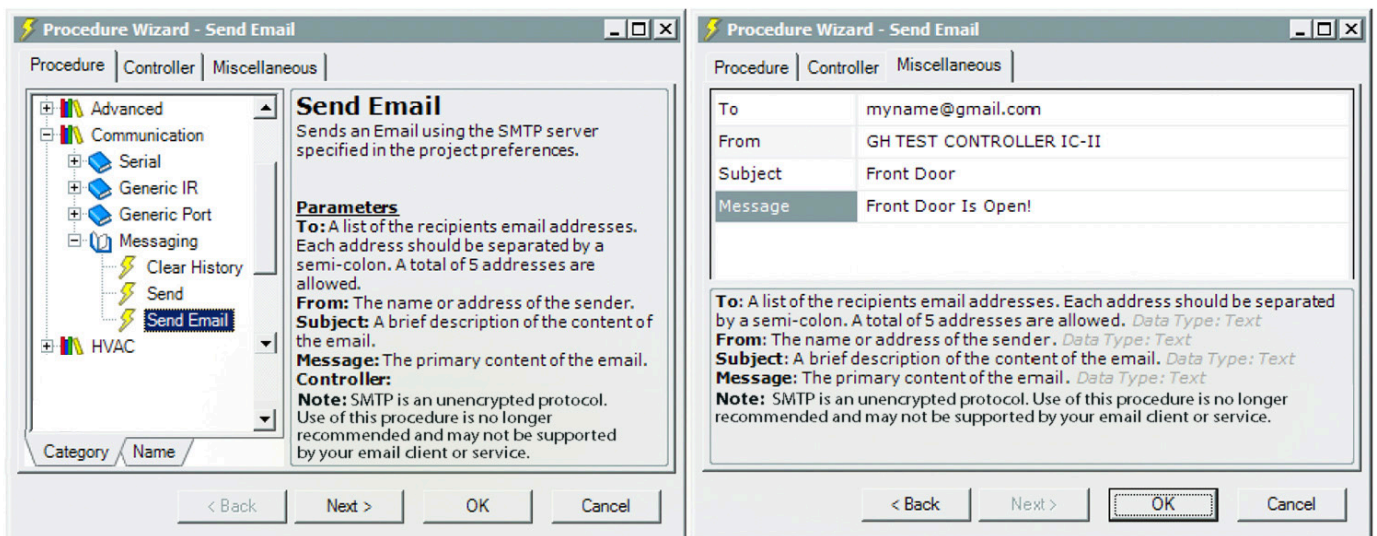

TERMINAL BOARD WIRING TYPE

TERMINAL BOARD

PART #: VSUB215 (Pre-Installed in Main Enclosures)

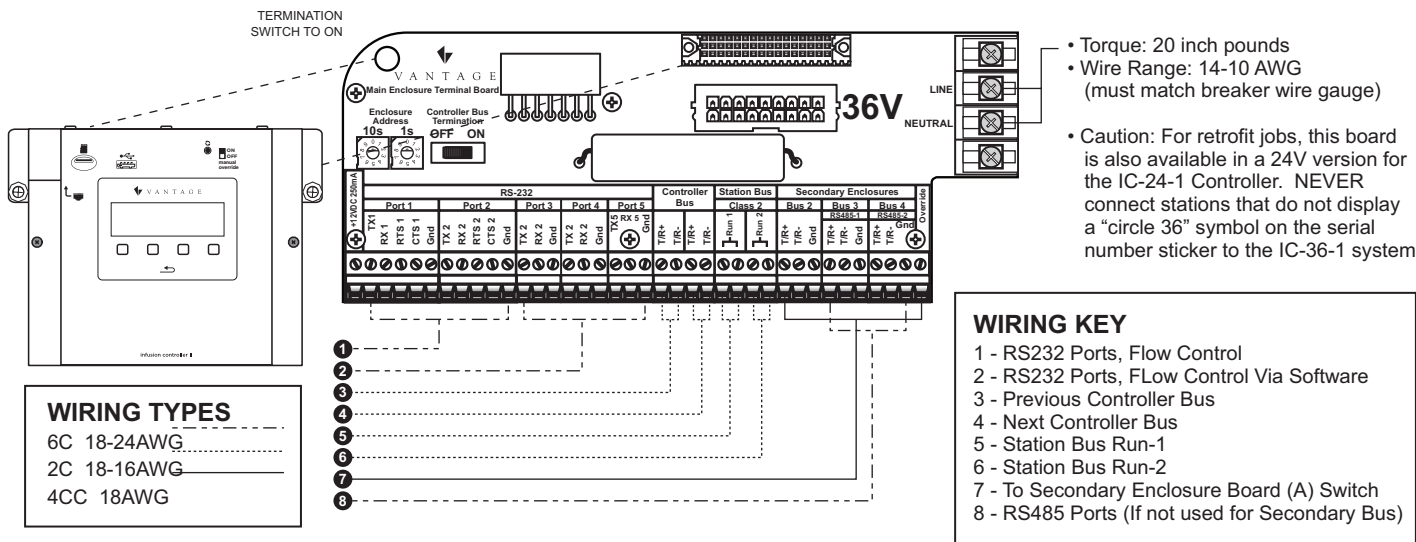

INFUSION LOOPED ENCLOSURE MANUAL OVERRIDE WIRING EXAMPLE

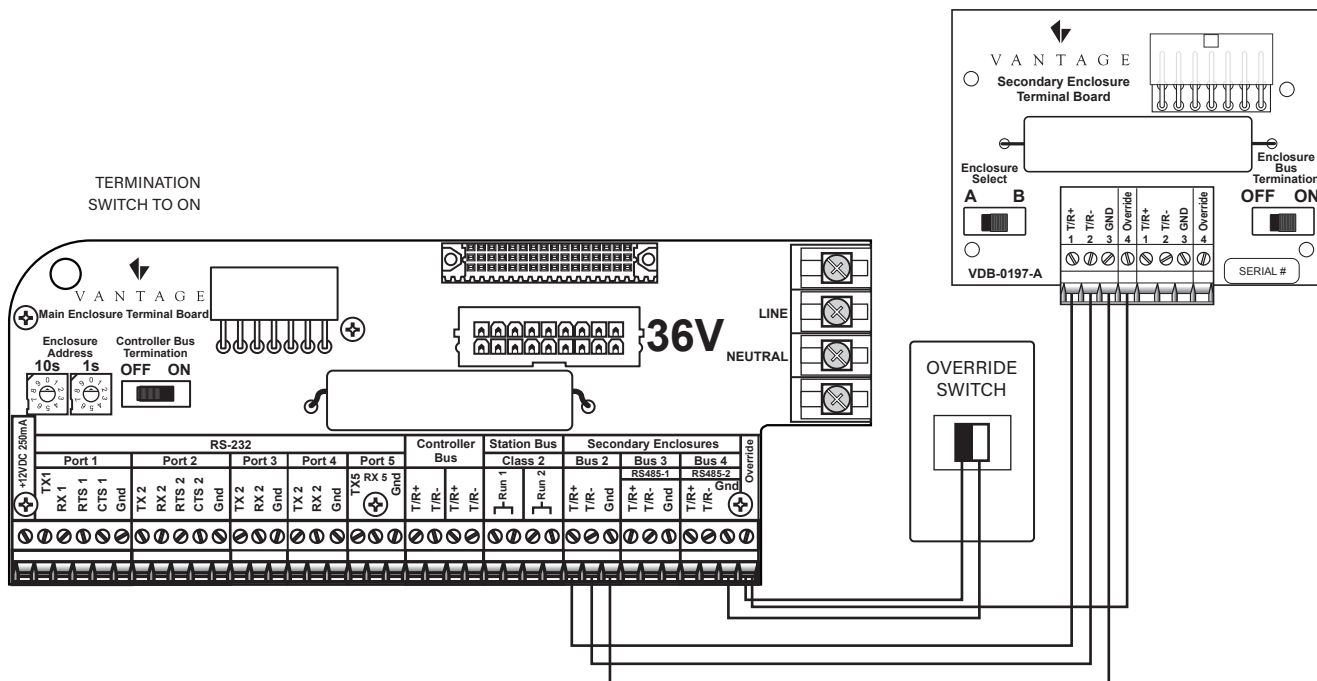

SECONDARY ENCLOSURE TERMINAL BOARD WIRING

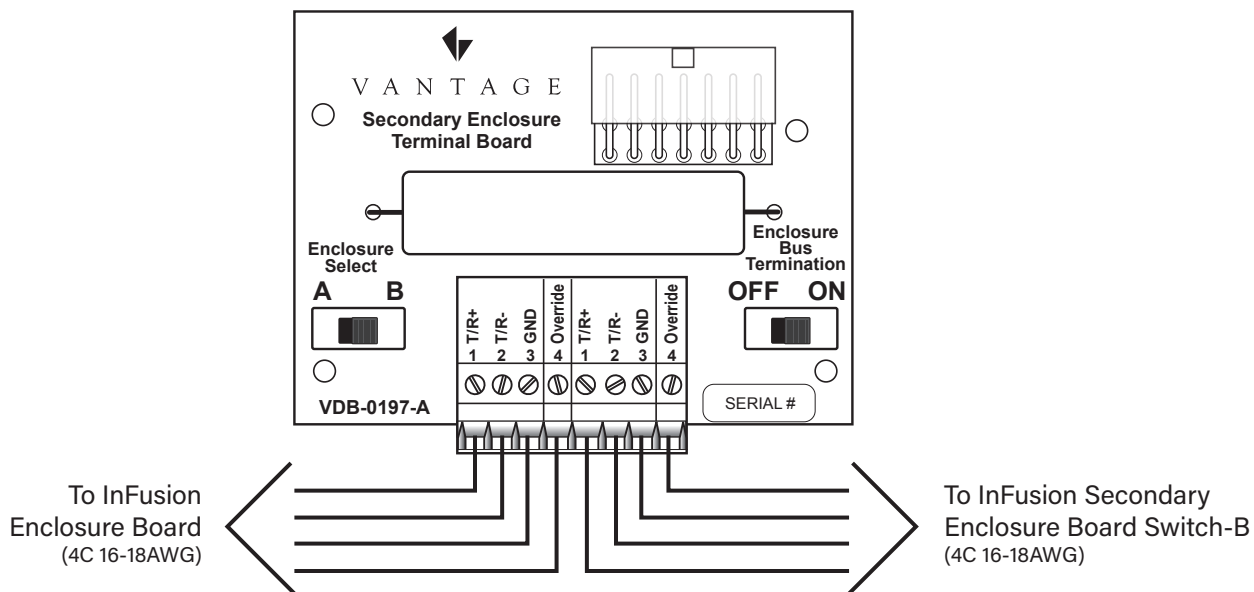

INFUSION INDIVIDUAL ENCLOSURE MANUAL OVERRIDE WIRING EXAMPLE

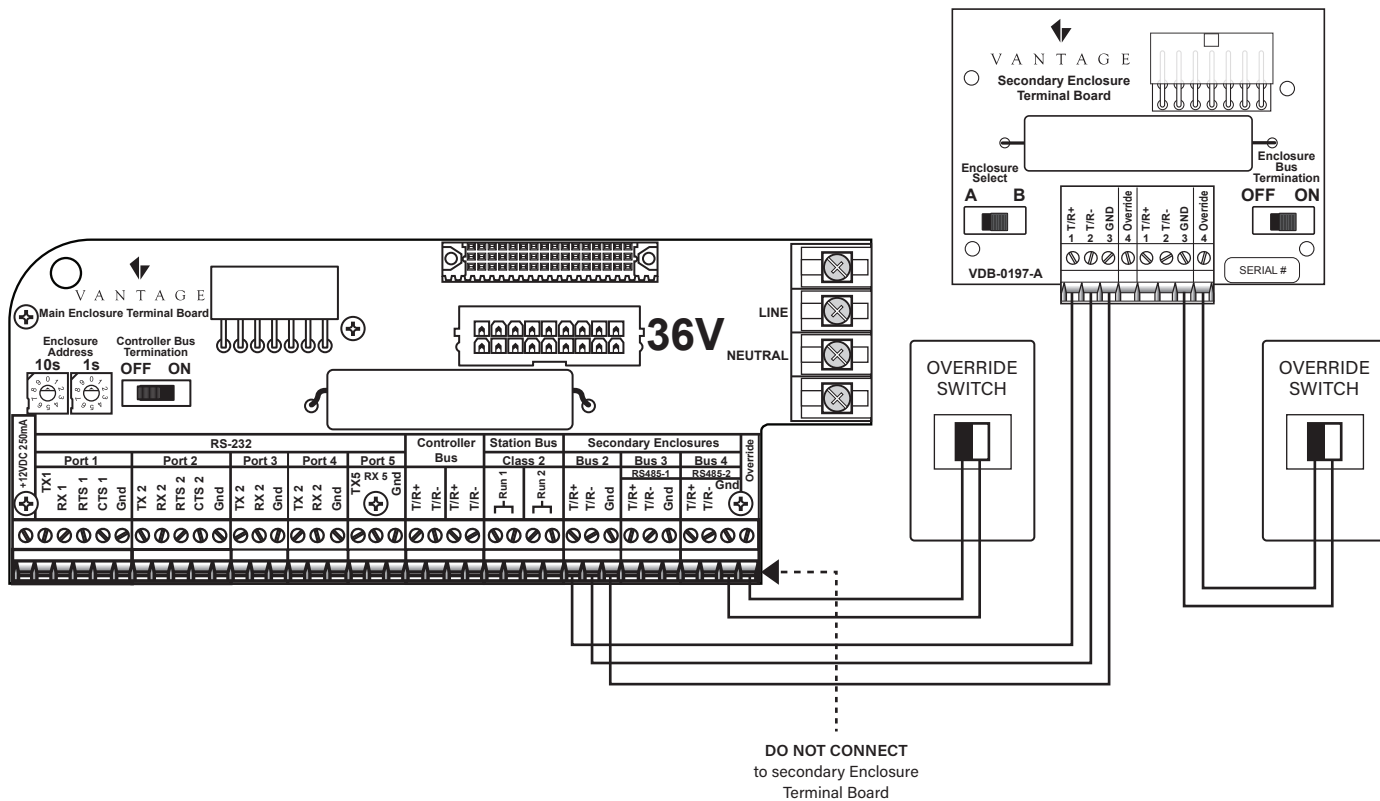

MULTI-VIEW LINE DRAWING

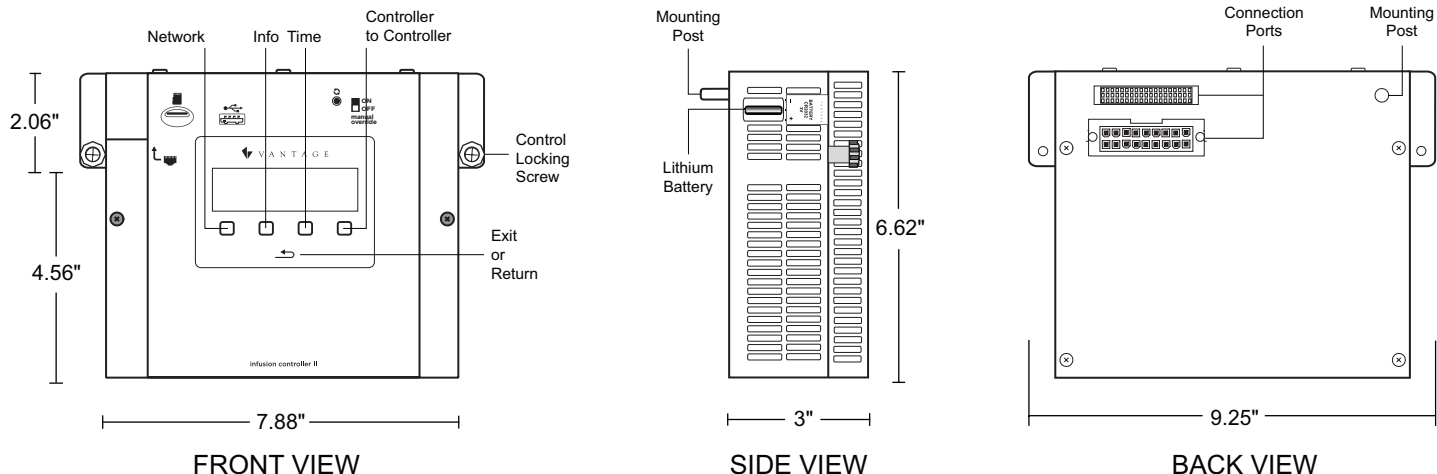

WARRANTY INFORMATION

Vantage warrants its products to be free of defects in materials and workmanship for a period of five (5) years. There are no obligations or liabilities on the part of Vantage for consequential damages arising out of, or in connection with, the use or performance of this product or other indirect damages with respect to loss of property, revenue or profit, or cost of removal, installation or reinstallation.

INFORMATIONS RELATIVES À LA GARANTIE

Vantage garantit que ses produits sont exempts de défauts de matériaux et de fabrication pour une période de cinq (5) ans. Vantage ne peut être tenu responsable de tout dommage consécutif causé par ou lié à l'utilisation ou à la performance de ce produit ou tout autre dommage indirect lié à la perte de propriété, de revenus, ou de profits, ou aux coûts d'enlèvement, d'installation ou de réinstallation.

INFORMACIÓN DE LA GARANTÍA

Vantage garantiza que sus productos están libres de defectos en materiales y mano de obra por un período de cinco (5) años. No existen obligaciones ni responsabilidades por parte de Vantage por daños consecuentes que se deriven o estén relacionados con el uso o el rendimiento de este producto u otros daños indirectos con respecto a la pérdida de propiedad, renta o ganancias, o al costo de extracción, instalación o reinstalación.