

Features:

- Supports 425Gbps
- Single 3.3V Power Supply
- Power dissipation < 10W
- Up to 10km over SMF
- RoHS compliant
- Commercial case temperature range: 0°C to 70°C
- QSFP-DD MSA Compliant
- 8x53.125Gbps(PAM4) electrical interface
- MPO-12 connector
- PIN and TIA array on the receiver side
- I2C interface with integrated Digital Diagnostic Monitoring



- Safety Certification: TUV/UL/FDA

Applications:

- 4 x 100G LR applications
- Data center
- Enterprise networking
- Infiniband interconnects

1. Absolute Maximum Ratings

Exceeding the absolute maximum ratings table may cause permanent damage to the device. This is just an emphasized rating, and does not involve the functional operation of the device that exceeds the specifications of this technical specification under these or other conditions. Long-term operation under absolute maximum ratings will affect the reliability of the device.

Parameter		Symbol	Min.	Typ.	Max.	Unit	Note
Storage Temperature		Ts	-40		+85	°C	
Relative Humidity		RH	-0.5	3.3	3.6	V	
Supply Voltage		Vcc	-0.5	3.3	3.6	V	
Data Input Voltage	Single Ended	Rxdmg	5.5			dBm	
	Differential				0.8	V	1

Note:

1. This is the maximum voltage that can be applied across the differential inputs without damaging the input circuitry. The damage threshold of the module input shall be at least 1600 mV peak to peak differential.

2. Recommended Operating Conditions

For operations beyond the recommended operating conditions, optical and electrical characteristics are not defined, reliability is not implied, and such operations for a long time may damage the module. Power Supply specifications, Instantaneous, sustained and steady state current compliant with QSFP-DD MSA Power Classification.

Parameter	Symbol	Min.	Typ.	Max.	Unit	Note
Operating Case Temperature	T _c	0		70	°C	1
Power Supply Voltage	V _{cc}	3.135	3.3	3.465	V	
Power Supply Noise				50	mVpp	2
Power Dissipation	P _D			10	W	
Electrical Signal Rate Per Channel			26.5625		GBd	3
Optical Signal Rate Per Channel			53.125		GBd	4
Receiver Differential Data Output Load		100			Ohm	
Fiber Length				10000	m	5

Notes:

1. The position of case temperature measurement is shown in Figure 9. Continuous operation at the maximum Recommended Operating Case Temperature should be avoided in order not to degrade reliability.
2. Power Supply Noise is defined as the peak-to-peak noise amplitude over the frequency range at the host supply side of the recommended power supply filter with the module and recommended filter in place. Voltage levels including peak-to-peak noise are limited to the recommended operating range of the associated power supply. See Figure 9 for recommended power supply filter.
3. 400GAUI-8 operation with Host generated FEC. The transmitter must receive pre-coded FEC signals from the host ASIC.
4. 400G LR4 operation with Host generated FEC. The transmitter must receive pre-coded FEC signals from the host ASIC.
5. 9µm SMF. The maximum link distance is based on an allocation of 1dB of attenuation and 3dB total connection and splice loss. The loss of a single connection shall not exceed 0.5dB.

3. General Electrical Characteristics

Unless otherwise stated, the following characteristics are defined under recommended operating conditions. For control signal timing including LPWn/PRSn, INT/RSTn, SCL and SDA see Control Interface Section.

Parameter	Symbol	Min.	Typ.	Max	Unit
Transceiver Power Consumption			8	10	W
Transceiver Power Supply Total Current			2600	3200	mA
AC Coupling Internal Capacitor			0.1		µF

4. Reference Points

Test Point	Description
TP0 to TP5	This channel includes transmitter and receiver differential control impedance printed circuit board insertion loss and cable assembly insertion loss.
TP1 to TP4	All cable assembly measurements are made between TP1 and TP4 as illustrated in Figure 3.
TP0 to TP2 TP3 to TP5	A mated connector pair has been included in both the transmitter and receiver specifications defined in 802.3cd 136.9.3 and 136.9.4. The recommended maximum insertion loss from TP0 to TP2 or from TP3 to TP5 including the test fixture is provided in 802.3cd 136.9.3.2
TP2	Unless specified otherwise, all transmitter measurements defined in 802.3cd 136.9.3 are made at TP2 utilizing the test fixture specified in Annex 136B.
TP3	Unless specified otherwise, all receiver measurements and tests defined in 802.3cd 136.9.4 are made at TP3 utilizing the test fixture specified in Annex 136B.

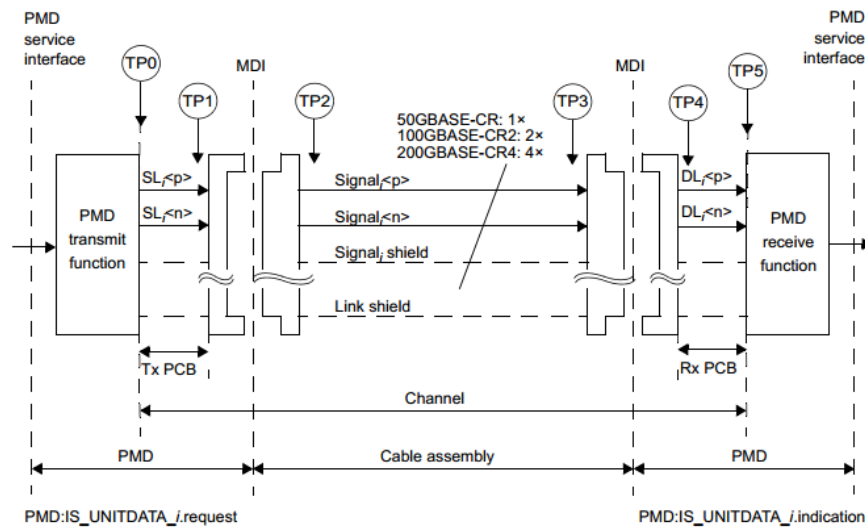

Figure 3: IEEE 802.3cd 50GBASE-CR, 100GBASE-CR2 or 200GBASE-CR4 link

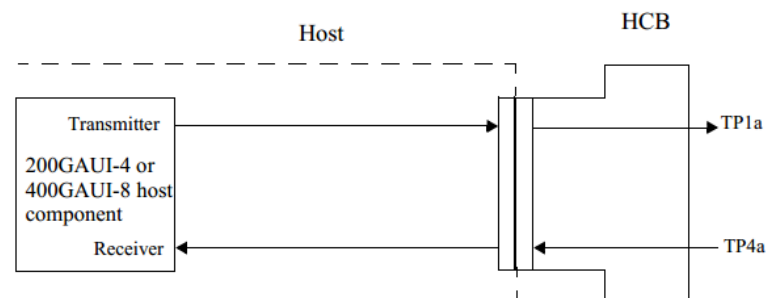

Figure 4: IEEE 802.3bs 400GAUI-8 compliance points TP1a, TP4a

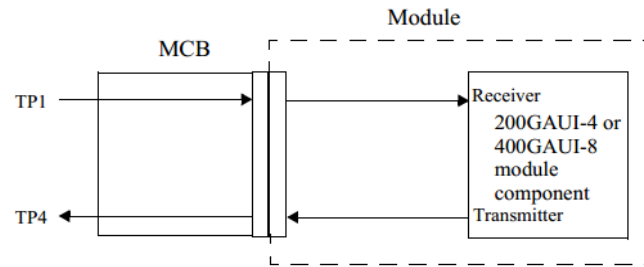

Figure 5: IEEE 802.3bs 400GAUI-8 compliance points TP1, TP4

5. High Speed Electrical Input Characteristics

Unless otherwise stated, the following characteristics are defined under recommended operating conditions.

Parameter	Test Point	Min.	Typical	Max.	Unit	Conditions	Note
Signaling Rate, Per Lane (PAM4 encoded)	TP1		26.5625		GBd	+/- 100 ppm	
Differential pk-pk Input Voltage Tolerance	TP1a	900			mV		
Differential input Return Loss (min)	TP1		Equation (83E-5)		dB	802.3bs	
Differential to common mode input return loss (min)	TP1		Equation (83E-6)		dB	802.3bs	
Differential Termination Mismatch	TP1		10		%		
Single-ended voltage tolerance range	TP1a	-0.4		3.3	V		
DC common-mode output voltage	TP1	-350		2850	mV		1
Module stressed input test							2
Eye width			0.22		UI		
Applied pk-pk sinusoidal jitter			Table 120E-6			802.3bs	
Eye height			32		mV		
Applied pk-pk sinusoidal jitter			Table 120E-6			802.3bs	

Note:

- DC common mode voltage generated by the host. Specification includes effects of ground offset voltage.
- Module stressed input tolerance is measured using the procedure defined in 120E.1.1.

6. High Speed Electrical Output Characteristics

Unless otherwise stated, the following characteristics are defined under recommended operating conditions.

Parameter	Test Point	Min.	Typical	Max.	Unit
Signaling Rate Per Lane(Range)	TP4a		26.5625		GBd
Differential peak-to-peak input voltage tolerance	TP4	900			mV
Differential input Return Loss (min)	TP4a		Equation (83E-2)		dB
Differential to common mode input return loss (min)	TP4a		Equation (83E-3)		dB
Differential termination mismatch	TP4a			10	%
Common mode voltage	TP4a	-0.35		2.85	V
Transition time (20% to 80%)	TP4	9.5			ps

7. High Speed Optical Transmitter Characteristics

Unless otherwise stated, the following characteristics are defined under recommended operating conditions.

Parameter	Symbol	Min.	Typical	Max.	Unit	Note
Optical Characteristics @TP2 Test Point						
Signaling Speed Per Lane			106.25		Gbps	
Modulation Format			PAM4			
Center Wavelength	λ	1304.5	1311	1317.5	nm	
Side-Mode Suppression Ratio	SMSR	30			dB	
Extinction Ratio	ER	3.5			dB	
Average Launch Power		-1.4		4.5	dBm	1
OMA Per Lane		0.7		4.7	dBm	
Launch Power in OMA-TDECQ for extinction ratio ≥ 4.5 dB for extinction ratio < 4.5 dB		-0.7 -0.6			dBm	
Transmitter and dispersion eye closure for PAM4 (TDECQ)				3.4	dB	
TECQ (PAM4)				3.4	dB	
TDECQ - $10 \cdot \log_{10} (C_{eq}) \cdot 15$				3.4	dB	2
RIN15.6 OMA				-136	dB/Hz	
Average launch power of OFF transmitter				-15	dBm	
Optical return loss tolerance				15.6	dB	

Transmitter Reflectance				-26	dB	
Transmitter transition time				17	ps	
Transmitter over/under-shoot				22	%	

Note:

1. Average launch power, each lane (min) is informative and not the principal indicator of signal strength. A transmitter with launch power below this value cannot be compliant; however, a value above this does not ensure compliance.
2. Ceq is a coefficient defined in IEEE Std 802.3-2018 clause 121.8.5.3 which accounts for reference equalizer noise enhancement.

8. High Speed Optical Receiver Characteristics

Unless otherwise stated, the following characteristics are defined under recommended operating conditions.

Parameter	Symbol	Min.	Typical	Max.	Unit	Note
Optical Characteristics @TP3 Test Point						
Signaling Speed Per Lane			106.25		Gbps	
Center Wavelength	λ	1304.5	1311	1317.5	nm	
Damage threshold		5.5			dBm	
Average receiver power per lane		-7.7		4.5	dBm	
Saturation receive power (OMA) per Lane				4.7	dBm	
Unstressed receiver sensitivity (OMA) per Lane for TECQ < 1.4 dB for 1.4 dB ≤ TECQ ≤ 3.4 dB	Sen			-6.1 TECQ- 7.5	dBm	1
LOS Assert (Avg.)	LOSA	-15			dBm	
LOS De-Assert (Avg.)	LOSD			-10	dBm	
LOS Hysteresis		0.5			dB	
RSSI accuracy		-2		+2	dB	
Receiver reflectance				-26	dB	

Note:

1. Measured with conformance test signal at TP3 for the BER specified in IEEE Std 802.3cd clause 140.1.1.

9. Mechanical Diagram

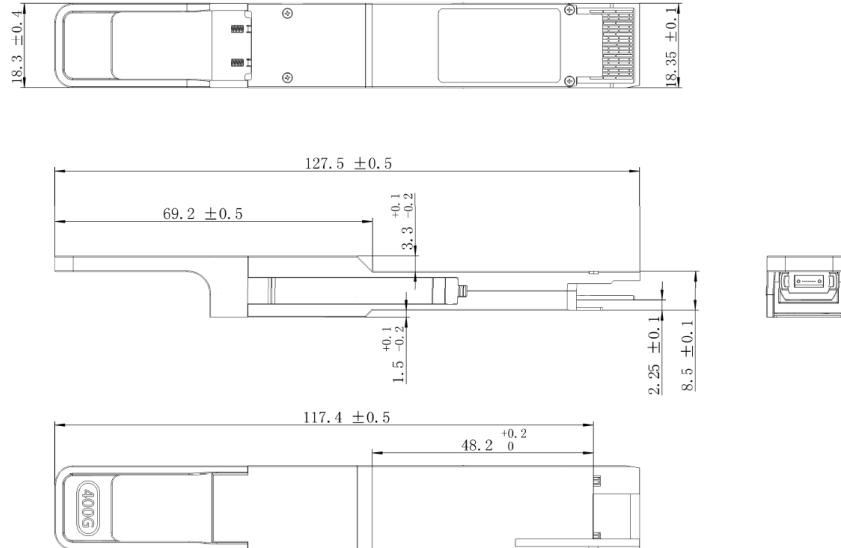

Note: External physical characteristics are subject to variation. This may include, but is not limited to, external case designs, pull tab colors and/or shapes, removal latch styles or colors, and label sizes and placement. These variations do not affect the function or characteristics of the transceivers.

The below picture shows the location of the hottest spot for measuring module case temperature. In addition, the digital diagnostic monitors (DDM) temperature is also calibrated to this spot.

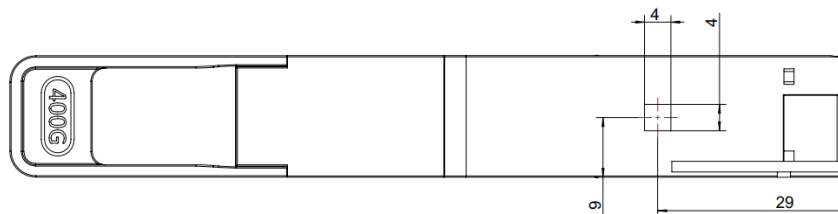

The optical interface port is a male MPO-12 connector as specified in TIA-604-5.

MPO-12

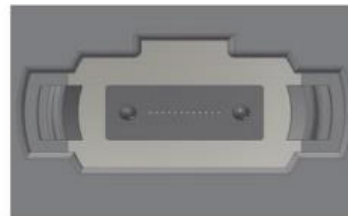
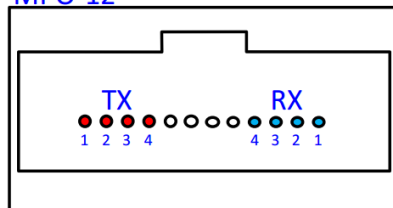

10. Ordering Information

OEM	Part Number	OEM	Part Number
Arista	QDD-400G-PLR4-A	Cisco	QDD-4X100G-LR-S-A
Juniper	QDD-4X100G-LR-A		

11. Contact Information

Tel: 800.590.9535

Web: <http://www.approvednetworks.com>