

Catalog Number • Le Numéro de Catalogue • Número de Catálogo: LMGS-150-PB

Country of Origin: Made in China • Pays d'origine: Fabriqué en Chine • País de origen: Hecho en China

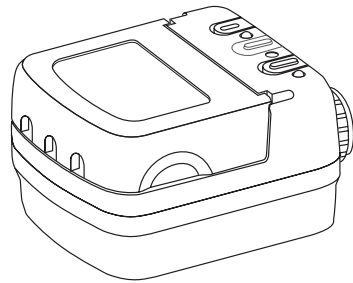
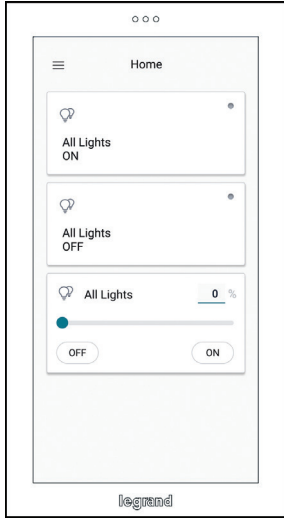

DESCRIPTION AND OPERATION

The LMGS-150 graphic switch is a native DLM wired device with a 5.7" capacitive touch LCD display that enables simple control of lights, shades, and scenes. The LMGS-150 is compatible with wired DLM rooms, LMCP panels, and LMZC-301 zone controllers and connects to the DLM local network using a single Cat5e cable for communication and 24VDC low voltage power. For ease of installation, each LMGS-150 includes a plenum rated KO mount power supply (LMPB-100). Wattstopper Plug n Go™ (PnG) automatically configures the user interface with default screen settings without requiring any programming. The device is fully programmable and field upgradeable using LMCS-100 5.13 or later.

SPECIFICATIONS

Voltage	24VDC
Current Consumption	150 mA
Power Supply	DLM Power Booster (LMPB-100 included)
Display.....	5.7" Diagonal, Full Color, High Resolution, TFT Capacitive Touch LCD, 1440x720, 282ppi , 18:9 Aspect Ratio
Mounting Orientation	Portrait
Connection to the DLM Local Network.....	1 RJ-45 Port
DLM Local Network characteristics:	
Low voltage power provided over Cat 5e cable (LMRJ).	
Max current: 800mA. Max total cable: 1000' Cable added per device: 150'. Max loads: 64. Max communicating devices: 24 if all power supplies are 10X-Series, 48 otherwise.	
Max 10X-Series power supplies: 5.	
Communications.....	1 USB-C Programming port (for field upgrades)
Finishes	Glass, Aluminum Alloy, Plastic
Operating Temperature	32°F to 122°F (0°C to 50°C)
Storage Temperature.....	-4°F to 140°F (-20°C to 60°C)
Operating Humidity.....	5% to 85% Non-condensing
Weight	6.4 oz.
Certifications.....	CE, FCC, RoHS
Warranty	Five years

CONNECTIVITY

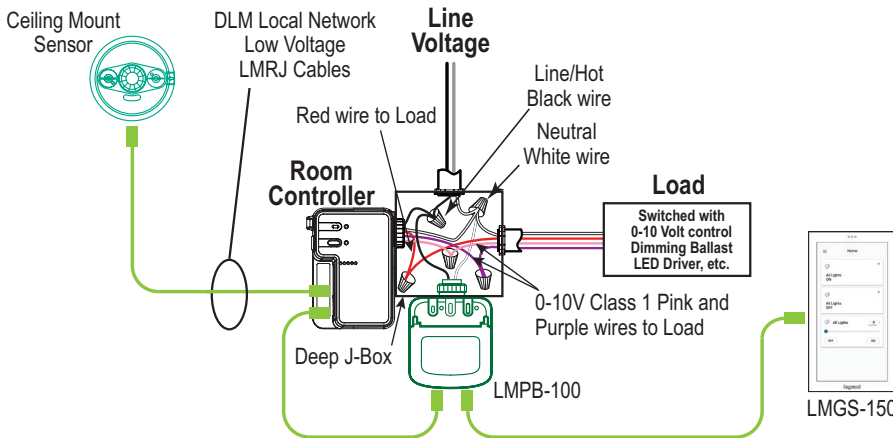

The LMGS-150-PB-x comes with an LMPB-100.

Maximum cable distance between the LMGS-150 and the LMPB-100 is 100 ft.

NOTE: After a power loss event, the LMGS-150 will automatically restart when power is restored to the IRB local network. The LMGS-150 takes approximately 90 seconds to restart before the user interface is available to control loads. After a power loss all loads will return to their previous state by default. By using LMCS, loads can be individually configured to turn On or Off.

CAUTION: TO CONNECT A COMPUTER TO THE DLM LOCAL NETWORK USE THE LMCI-100. NEVER CONNECT THE DLM LOCAL NETWORK TO AN ETHERNET PORT – IT MAY DAMAGE COMPUTERS AND OTHER CONNECTED EQUIPMENT.

FRONT AND BACK VIEW

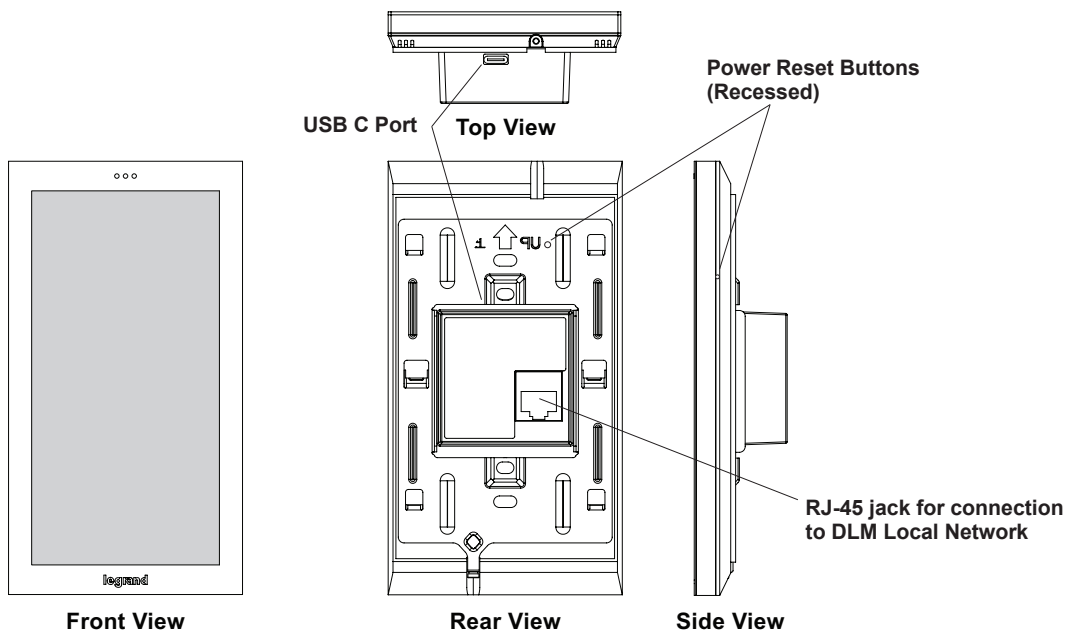

MOUNTING

The LMGS-150 Graphic Switch is designed to mount onto a standard single-gang junction box or low voltage ring, using the supplied mounting plate with security screw. The LMGS-150 then attaches to the mounting plate via tabs and slots. The mounting plate includes screw holes for both U.S. (83.5mm) and International (60mm) J-Boxes. Minimum recommended junction box depth is 1 -7/8".

Recommended mounting height per ADA 2010 Design Standards is no higher than 48" above finished floor.

WARNING: Do not install to cover a junction box having Class 1, 3, or Power and Lighting Circuits.

Attach Mounting Plate to JBox

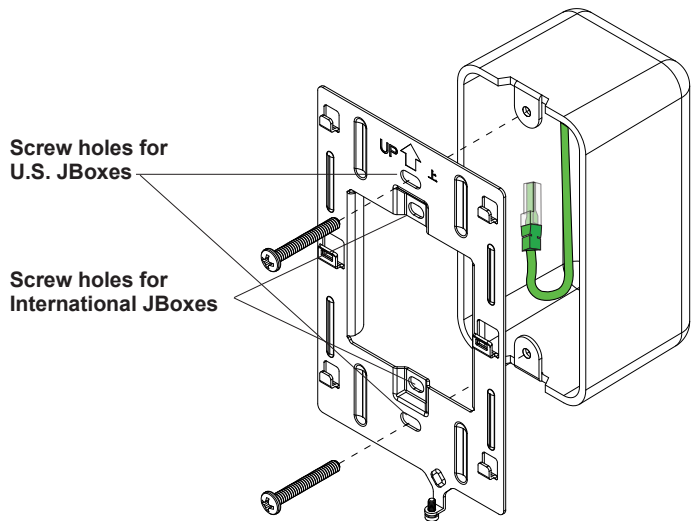

Attach LMGS-150 to Mounting Plate

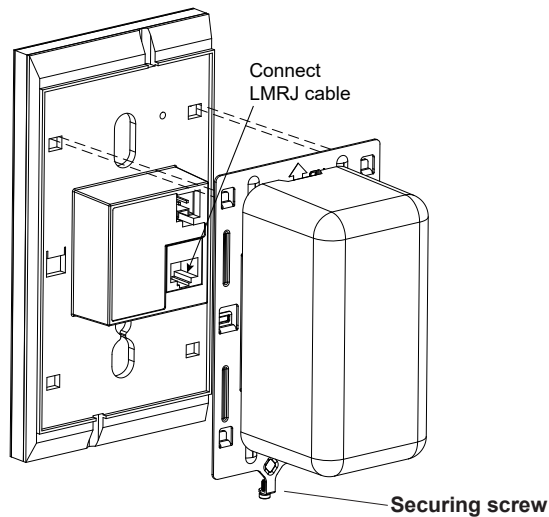

Insert tabs into slots, then slide down to lock in place. Secure the LMGS-150 to the mounting plate by tightening the screw

PLUG N' GO OPERATION (PNG)

The DLM Graphic Switch supports PnG to automatically create default screens and graphical buttons based on the load types in the room. All supported lighting loads are bound to lighting buttons and sliders on the Home, Lights, and Scenes pages. All supported shade loads are bound to shading buttons on the Home and Shades pages. Tap the Hamburger menu ☰ to navigate between the available screens.

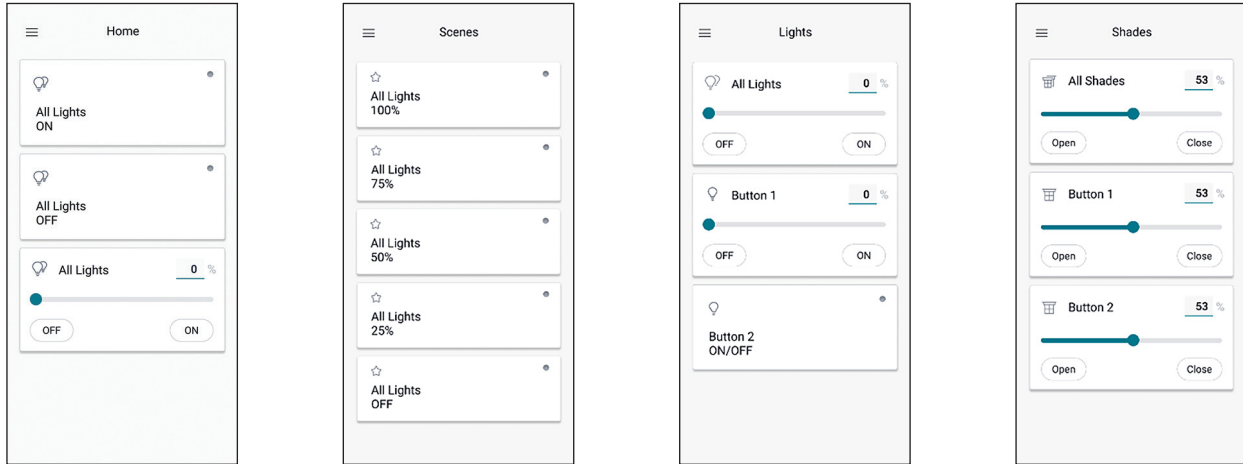

NOTE: All user interface customization is done using LMCS-100. Visit www.legrand.us/wattstopper/software for more information.

NOTE: LMCP panels and LMZC-301 zone controllers do not support PnG.

PROGRAMMING OVERVIEW

The LMGS-150 is programmed by authorized technicians using the LMCS-100 software version 5.13 or later. Programming steps are outlined in the LMCS user guide.

NOTE: The USB-C port is required when updating the LMGS APP UI version. The USB-C cable must support power and data. All other programming can be done using the LMCI-100.

NOTE: The LMCT-100-2 wireless configuration tool does not support the LMGS-150.

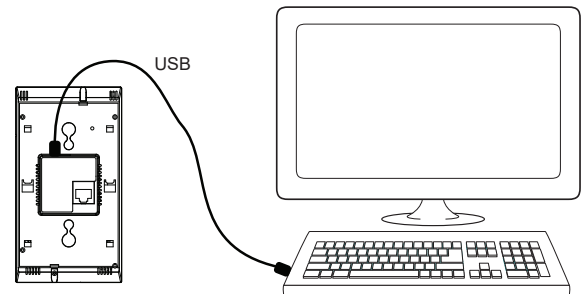

TROUBLESHOOTING

The LMGS-150 does not operate as expected.

The LMGS device does not power on	<ol style="list-style-type: none"> 1. Check to make sure the RJ45 is fully plugged into the LMGS and LMPB. 2. Test the cable to make sure the RJ45 terminations are correct. 3. Connect a known good device to the DLM local network to verify power.
The user interface is displaying “No loads Found”	<ol style="list-style-type: none"> 1. LMGS-150 does not support PnG when connected to an LMCP panel or LMZC-301. 2. When LMGS is connected to a wired room confirm check to make sure PnG is not locked.
The wrong loads are controlled	<ol style="list-style-type: none"> 1. Use LMCS-100 to configure the correct button load bindings.
The user interface isn't responding	<ol style="list-style-type: none"> 1. Locate the recessed reset button on the right side of the unit, press and release to power cycle the unit.

FCC REGULATORY STATEMENTS

This equipment has been tested and found to comply with the limits for a Class A digital device, pursuant to part 15 of the FCC Rules. These limits are designed to provide reasonable protection against harmful interference when the equipment is operated in a commercial environment. This equipment generates uses, and can radiate radio frequency energy and, if not installed and used in accordance with the instruction manual, may cause harmful interference to radio communications. Operation of this equipment in a residential area is likely to cause harmful interference in which case the user will be required to correct the interference at his own expense.

WARRANTY INFORMATION	INFORMATIONS RELATIVES À LA GARANTIE	INFORMACIÓN DE LA GARANTÍA
Wattstopper warrants its products to be free of defects in materials and workmanship for a period of five (5) years. There are no obligations or liabilities on the part of Wattstopper for consequential damages arising out of, or in connection with, the use or performance of this product or other indirect damages with respect to loss of property, revenue or profit, or cost of removal, installation or reinstallation.	Wattstopper garantit que ses produits sont exempts de défauts de matériaux et de fabrication pour une période de cinq (5) ans. Wattstopper ne peut être tenu responsable de tout dommage consécutif causé par ou lié à l'utilisation ou à la performance de ce produit ou tout autre dommage indirect lié à la perte de propriété, de revenus, ou de profits, ou aux coûts d'enlèvement, d'installation ou de réinstallation.	Wattstopper garantiza que sus productos están libres de defectos en materiales y mano de obra por un período de cinco (5) años. No existen obligaciones ni responsabilidades por parte de Wattstopper por daños consecuentes que se deriven o estén relacionados con el uso o el rendimiento de este producto u otros daños indirectos con respecto a la pérdida de propiedad, renta o ganancias, o al costo de extracción, instalación o reinstalación.