

# HIGH/LOW/OFF PIR FIXTURE INTEGRATED OUTDOOR PHOTO/MOTION SENSOR

FSP-2X1 SERIES



## PRODUCT OVERVIEW

The FSP-2x1 series are passive infrared (PIR) outdoor sensors that raise or lower the electric lighting level to high, low or off based on motion and/ or daylight contribution. Typically, once the sensor stops detecting movement and the time delay elapses, lights will first fade to low mode, and eventually switch off. When motion is detected, the sensor ramps the light level to high mode unless the daylight contribution is sufficient. The integral photocell can also switch the lights on and off for dusk to dawn control so that lighting remains on overnight even without motion detection.

These slim, low-profile sensors are designed for installation inside the bottom of a light fixture body and is UL listed for use in wet and cold locations.

Initial setup and subsequent sensor adjustments are made using a wireless handheld configuration tool (FSIR-100). This tool enables adjustment of sensor parameters including high/low mode, sensitivity, time delay, cut off and more.

The FSIR-100 can read current parameter settings and stores up to six sensor parameter profiles to speed commissioning of multiple sensors.

### FSP-2x1 sensor module

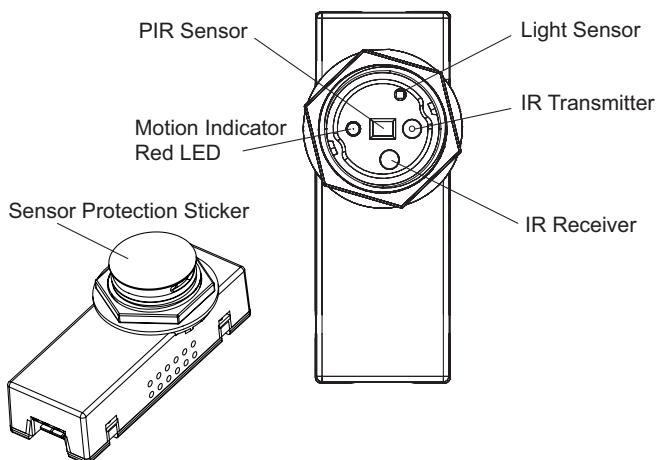

**NOTE: Remove Sticker before use**

## MODELS

FSP-201, 12–32VDC

Use with dim-to-off driver or ballast or with Wattstopper power pack

FSP-211, 120/277VAC, 230–240VAC (single phase), 50/60Hz

FSP-221, 100–347VAC (single phase) or 208/230/480VAC (phase-to-phase)

## SPECIFICATIONS & FEATURES

Load Ratings (FSP-211, FSP-221):

@ 120V 0–800W tungsten, ballast, LED driver; 1/6hp motor

@ 230–240V 0–300W ballast, LED driver

@ 277V 0–1200W ballast, LED driver; 1/6hp motor

@ 347V 0–1200W ballast, LED driver, (FSP-221 only)

@ 480V 0–1200W ballast, (FSP-221 only)

Current consumption (FSP-201):

Normal Operation: 15mA

IR Programming: 45mA

0–10V sinking current: 50mA

Three interchangeable lenses for mounting between 8' and 40'

Remote setup and adjustment with handheld wireless configuration tool

Adjustable high and low modes (high: 0 to 10V, low: off, 0 to 9.8V)

Adjustable time delay (30 seconds, 5 to 30 minutes)

Adjustable cut off delay (none, 1 to 59 minutes, 1 to 5 hours)

Adjustable sensitivity (low, med, max)

Adjustable setpoints: hold off setpoint (none, 1 to 250 fc, auto); photocell on/off setpoint (1 to 250 fc)

Adjustable ramp and fade times (1 to 60 seconds)

Lead length (FSP-221): 12" (30.5cm)

Operating temperature: -40°F to +167°F (-40°C to +75°C)

Weight: FSP-201, 2.1 oz (59 g);  
FSP-211 2.8 oz (80 g),  
FSP-221, 5.5 oz (155 g)

UL and cUL listed; CE; TUV listed

IP66 rated

FSIR-100 is FCC Part 15 compliant

Five year warranty

## MATERIALS

Polycarbonate, flame retardant, UV resistant, impact resistant, recyclable

Meets materials restrictions of RoHS

\*PEP designation applies to FSP-211 only

**DIMENSIONS**

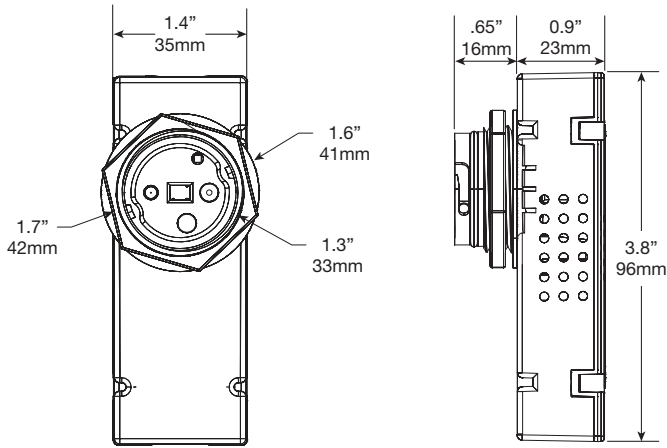

**FSP-201 & FSP-211**

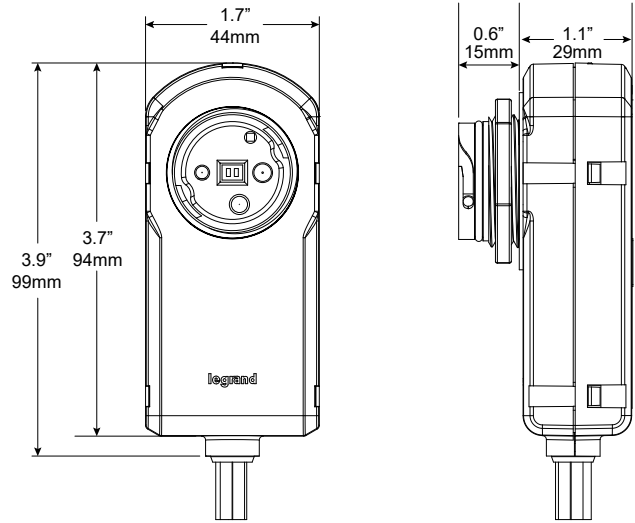

**FSP-221**

**COVERAGE**

**FSP-L2 top and side coverage patterns**

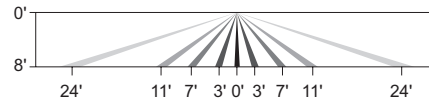
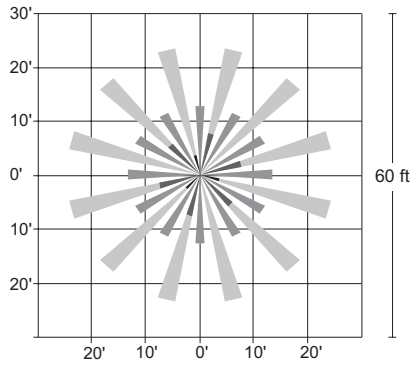

**FSP-L3 top and side coverage patterns**

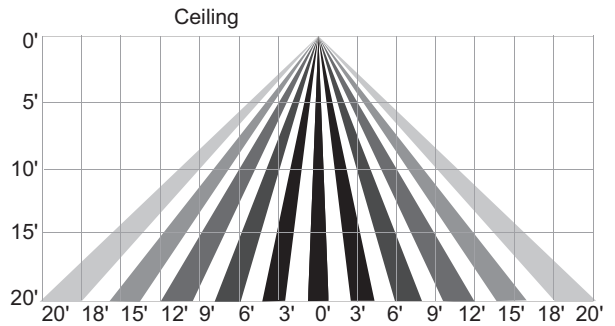
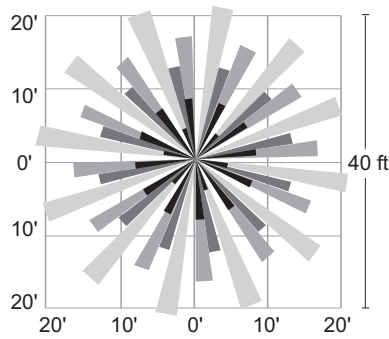

**FSP-L7 top and side coverage patterns**

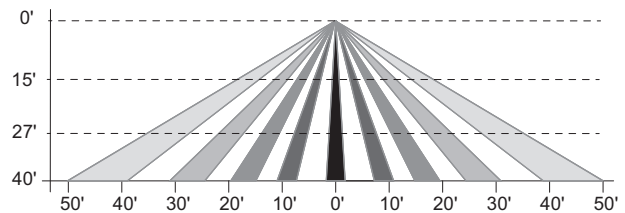
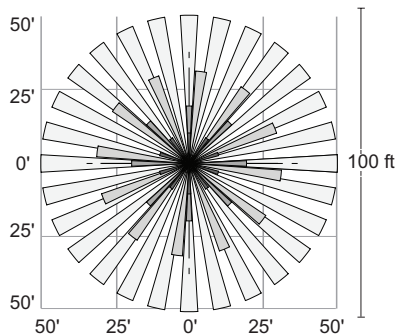

## DIMENSIONS OF LENS OPTIONS

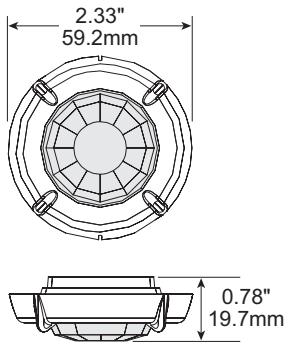

FSP-L2 dimensions

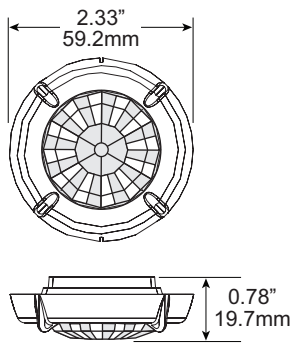

FSP-L3 dimensions

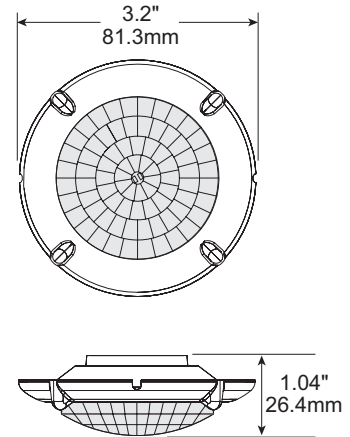

FSP-L7 dimensions

### FSP-L2-S, FSP-L3-S, and FSP-L7-S Dimensions

The FSP-Lx-S models include a shroud, which blocks high-angle light coming from the fixture, to improve photocell performance. With the shroud attached, the dimensions for all three lenses are identical

#### FSP-L2-S and FSP-L3-S

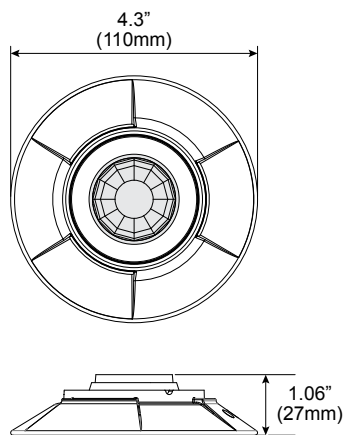

#### FSP-L7-S

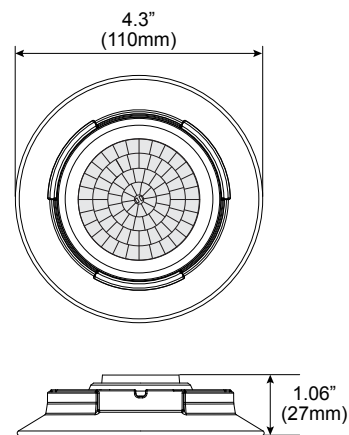

## INSTALLING THE FSP-2X1 SENSOR IN LIGHT FIXTURE

1. Determine an appropriate mounting location inside the light fixture. Allow a minimum distance of 0.2" (5.1mm) from the end of the sensor to the wall of the fixture.
2. Drill a 1.31" (33.3mm) diameter hole through the sheet metal in the bottom of the fixture.
3. Place the rubber gasket on the threaded collar, and install the sensor face down, parallel to the mounting surface. Ensure the rubber gasket touches the inside surface of the fixture. Install the tightening nut securely against the fixture and torque to 25-30 in-lbs to maintain IP rating.
4. Align the locking features between the sensor and lens module and push the lens module forward until the O-ring seals firmly. Turn the lens module clockwise to lock in place.

5. Connect load, supply and control wires
6. Restore power from the circuit breaker.

**NOTE:** An optional collar can be installed in place of the tightening nut on the FSP-2x1

**NOTE:** An optional shroud with integrated lens can be installed instead of the collar and a regular lens. The shroud blocks high-angle light coming from the fixture, to improve photocell performance.

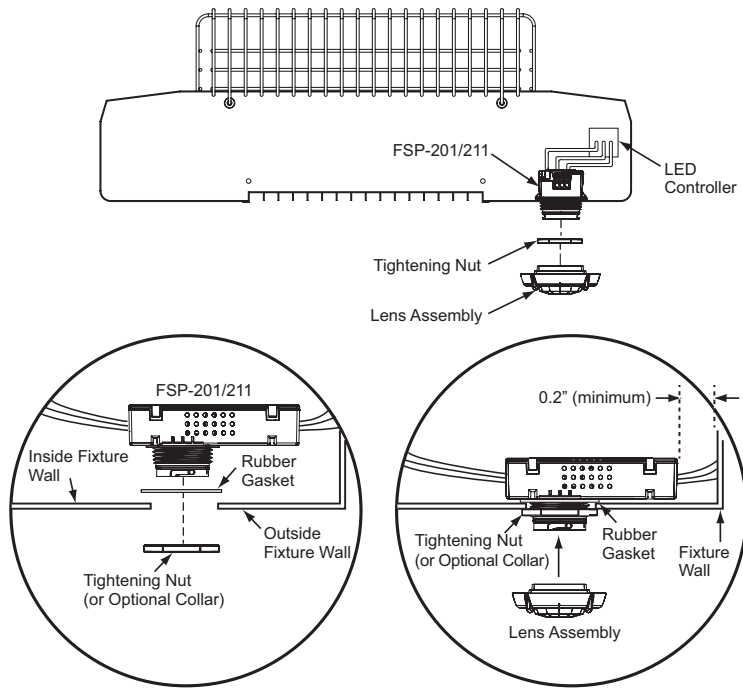

FSP-201 & FSP-211

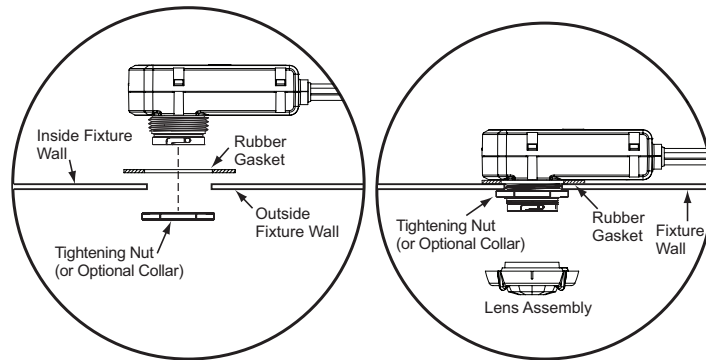

FSP-221

**NOTE:** The outside fixture wall thickness should be no greater than 0.125" (3.18mm) for optimal sensor mounting and security.

## SEQUENCE OF OPERATION

1. **Dimming:** When motion is detected within the sensor's coverage area, the sensor sends a signal to ramp the load up to the selectable High Mode level unless the ambient light level is higher than the selected setpoint. When no motion is detected for the duration of the time delay setting (factory preset at 5 minutes), the lights will go to the selectable Low Mode level based on the signal from the sensor. If desired, a cut off time delay (factory preset at 1 hour) will trigger to eventually turn the lights OFF.
2. **Non dimming:** When motion is detected within the sensor's coverage area, the sensor sends a signal to turn the load ON unless the ambient light level is higher than the selected setpoint. When no motion is detected for the duration of the time delay setting (factory preset at 5 minutes), the lights will go OFF based on the signal from the sensor.
3. **Dusk to dawn control:** When photocell on/off is enabled, and the ambient light falls below the photocell setpoint, the sensor ramps the load up to the selectable High Mode level. If no motion is detected for the duration of the time delay setting (factory preset at 5 minutes), the lights will go to the selectable Low Mode level. If the cut off time delay is disabled, the load will remain on, at High or Low level, based on motion detection, until the ambient light increases above the photocell setpoint.

## ADJUSTABLE CONTROL PARAMETERS

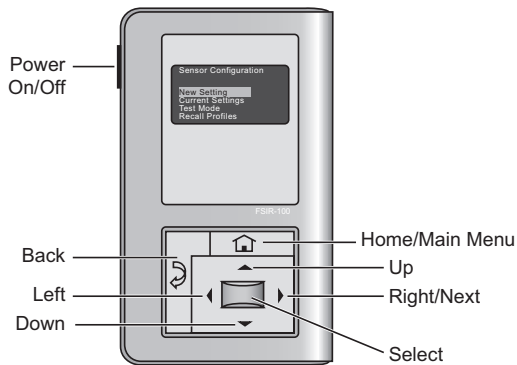

The FSIR-100 is a convenient handheld remote tool for setting up the FSP-2x1. Adjustable settings can be changed as needed for specific applications.

1. High Mode: When the sensor detects motion the dimming control output ramps up to the selected HIGH light level (default is 10V).
2. Low Mode: After the sensor stops detecting motion and the time delay expires the dimming control output fades down to the selected LOW light level (default is 1V).
3. Time Delay: The selected time period that must elapse after the last time the sensor detects motion for the electric lights to fade to LOW mode (default is 5 minutes).
4. Cut Off: The time period that must elapse after the lights fade to LOW mode and the sensor detects no motion for the electric lights to turn OFF (default is 1 hour).
5. Sensitivity: The response of the PIR detector to motion within the sensor's coverage area (default is max).
6. Setpoint: When enabled, the selectable ambient light level threshold that will hold the electric lights off or at LOW level when the sensor detects motion (default is disabled).

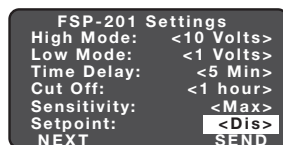
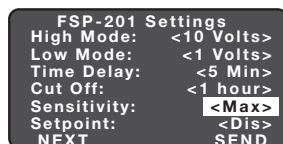
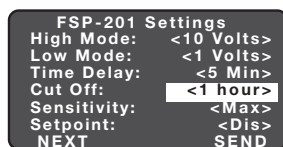
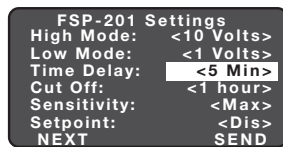
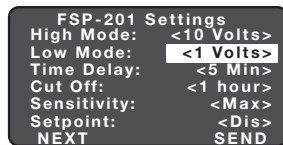
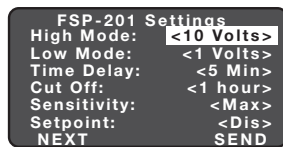

The Auto option invokes an automatic calibration procedure to establish an appropriate setpoint based upon the contribution of the electric light. As part of this procedure, the controlled load is turned on for two minutes to warm up the lamp, and then switched off and on eight times, terminating in an off state. After this process, a new setpoint value is automatically calculated.

7. Photocell On/Off: When enabled, the sensor will force the load OFF after the light level has exceeded the selected photocell setpoint for at least a minute. It will also force the load ON when the light level goes below the setpoint, even if no motion is detected (default if disabled). Once ON (initially at High), the load will dim to Low following the Time Delay, and to OFF following the Cut Off time. To ensure dusk to dawn control, Cut Off must be disabled.

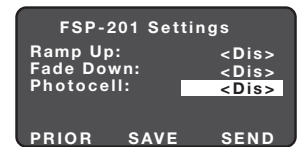

The photocell On/Off setpoint is automatically set to maintain a deadband of at least 10 fc above the Hold Off Setpoint to prevent cycling if the two features are used together.

8. Ramp Up Time: Time period for light level to increase from LOW to HIGH (default is disabled; lights switch instantly).
9. Fade Down Time: Time period for light level to decrease from HIGH to LOW (default is disabled; lights switch instantly).
10. Lock Settings: Time delayed IR communication lock initiated from the FSIR-100 to prevent unauthorized changes of FSP-2x1 parameters until power is cycled to the sensor (default is disabled).

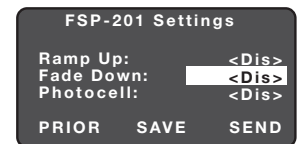
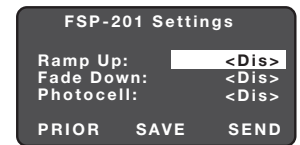

To lock settings, select Lock Delay, set a time, and press SEND to send the parameter change to FSP-2x1. After the countdown, FSP-2x1 will no longer respond to the FSIR-100. If additional configuration is required, cycle the power to the FSP-2x1 off and then back on. To disable the lock parameter after the power cycle, select Lock Delay, select Disable, and press SEND.

WIRING DIAGRAMS

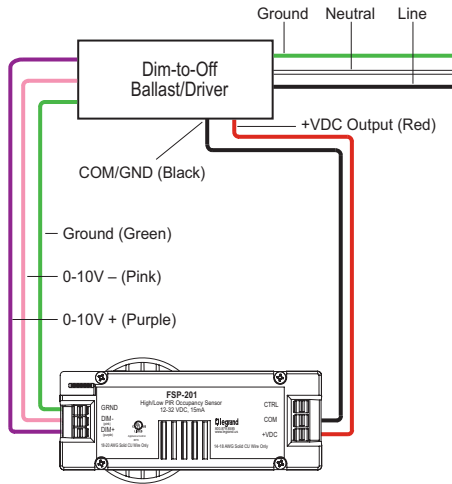

FSP-201 typical wiring with dim-to-off ballast or LED driver with auxiliary output.

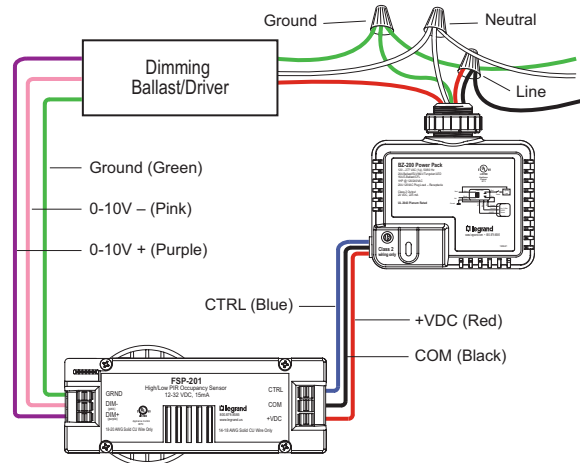

FSP-201 wiring with dimming ballast or LED driver and power pack for on/off control.

**NOTE:** Per UL, the 0-10V negative dimming wire color has been changed from gray to pink.

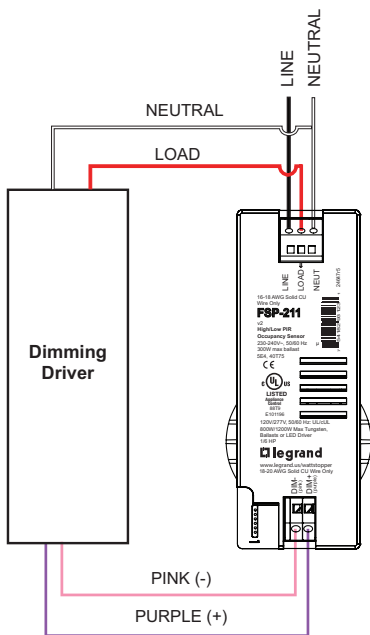

FSP-211 wiring with dimming ballast or LED driver.

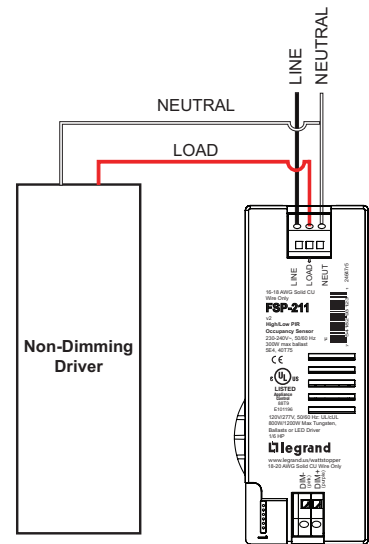

FSP-211 wiring with non-dimming ballast or LED driver.

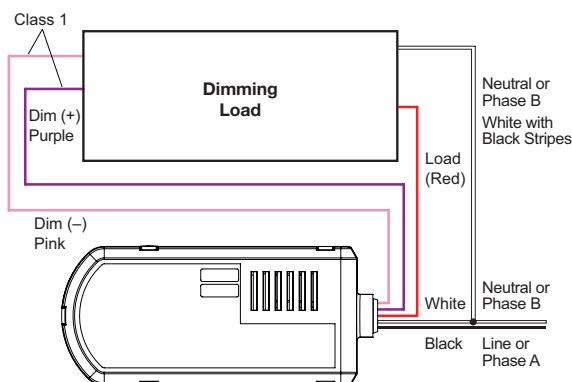

FSP-221 wiring with dimming ballast or LED driver

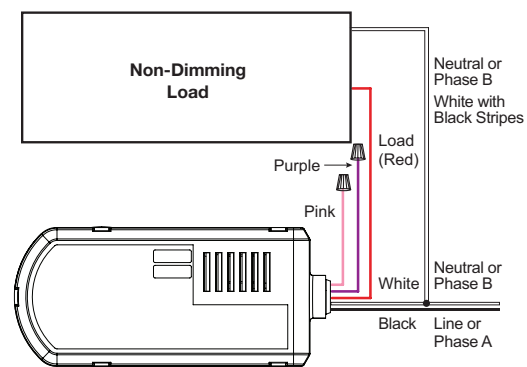

FSP-221 wiring with non-dimming load

## ORDERING INFORMATION

Catalog #	Master Pack Details					Inner Pack Details				
	Master Pack Quantity	Case dimensions (inches)			Weight (pounds)	Inner Pack Quantity	Case dimensions (inches)			Weight (pounds)
		Length	Width	Height			Length	Width	Height	
FSP-201	100	23.15	12.5	11.2	24	50	11.8	11.3	10	10.6
FSP-211	100	18.1	10.7	9.4	20.1	50	17.2	10.4	4.1	9.7
FSP-221	40	19.3	12.8	11.7	19.4	20	18.8	12.3	5.3	9
FSIR-100	40	12.8	14	10	17.3	10	9.4	6.1	6.7	4.1
FSP-L2	400	24.8	13.4	12.6	26.2	100	12.8	11.9	5.8	6.1
FSP-L3	400	24.8	13.4	12.6	26.2	100	12.8	11.9	5.8	6.1
FSP-L7	100	23.	15.4	9.3	13.7	50	22.8	7.1	8.1	5.95

Catalog #	Color	Description	Voltage
<input type="checkbox"/> FSP-201	White	Fixture mount, passive infrared motion sensor, low voltage	12-32 VDC
<input type="checkbox"/> FSP-211	White	Fixture mount, passive infrared motion sensor	120-277VAC, 50/60Hz
<input type="checkbox"/> FSP-211-U	White	Fixture mount, passive infrared motion sensor, BAA/TAA compliant*	
<input type="checkbox"/> FSP-221	White	Fixture mount PIR sensor, extended voltage	100-347VAC or 208/230/480VAC
<input type="checkbox"/> FSIR-100	Black	Remote Handheld Configuration Tool	Three standard 1.5 AAA alkaline batteries (included)
<input type="checkbox"/> FSP-L2	White	360° lens, maximum coverage 48' diameter from 8' height	
<input type="checkbox"/> FSP-L2-B	Black		
<input type="checkbox"/> FSP-L2-BR	Bronze		
<input type="checkbox"/> FSP-L2-G	Grey		
<input type="checkbox"/> FSP-L2-S	White	360° lens, maximum coverage 48' diameter from 8' height, with shroud; Minimizes high-angle light contribution to photocell	
<input type="checkbox"/> FSP-L3	White	360° lens, maximum coverage 40' diameter from 20' height	
<input type="checkbox"/> FSP-L3-B	Black		
<input type="checkbox"/> FSP-L3-BR	Bronze		
<input type="checkbox"/> FSP-L3-G	Grey		
<input type="checkbox"/> FSP-L3-S	White	360° lens, maximum coverage 40' diameter from 20' height, with shroud; Minimizes high-angle light contribution to photocell	
<input type="checkbox"/> FSP-L7	White	360° lens, maximum coverage 100' diameter from 40' height	
<input type="checkbox"/> FSP-L7-B	Black		
<input type="checkbox"/> FSP-L7-BR	Bronze		
<input type="checkbox"/> FSP-L7-G	Grey		
<input type="checkbox"/> FSP-L7-S	White	360° lens, maximum coverage 100' diameter from 40' height, with shroud; Minimizes high-angle light contribution to photocell	
<input type="checkbox"/> FSP-C1-W	White	Small collar, for use with FSP-L2 and FSP-L3 lenses (Optional aesthetic collar to transition from fixture housing to lens) Note: Not used with lenses that include shroud	
<input type="checkbox"/> FSP-C2-W	White	Large collar, for use with FSP-L7 lens (Optional aesthetic collar to transition from fixture housing to lens) Note: Not used with lens that includes shroud	

Note: Unless used with a driver or ballast with a low voltage power supply, the FSP-201 requires a Wattstopper power pack (ordered separately) to operate.

FSP-Lx series lens required for operation; order lens separately.

FSIR-100 required for configuration; order separately.

\*Product is compliant with Buy American Act and Trade Agreement Act

Information supplied above is subject to change.

Harmonization code: 8538908080. Country of origin: China or Mexico.

28373r9 Rev 01/2026