

MULTI-ZONE SWITCHING AND DIMMING OPEN LOOP PHOTOSENSOR

LMLS-500

Daylight responsive on/off, bi-level, tri-level or dimming control for up to three lighting zones

Extended tube model accommodates thicker ceiling materials

60 degree spatial response for optimal detection of daylight contribution



Automatic setpoint recommendations; optional hold off setting to maximize energy savings

Photodiode corrected to match the photopic response of the human eye

Can be calibrated in any daylight condition



DESCRIPTION

The LMLS-500 is an open loop, multi-zone photosensor that measures the daylight contribution in order to automatically switch or dim up to three zones of lighting. It is part of a Digital Lighting Management (DLM) system and sends light level signals to control loads connected to DLM on/off or dimming room controllers. The LMLS-500 has a photodiode with an extended range of 1–1,500 footcandles (fc), and photopic correction to mimic the human eye, for precise measurement of visible light.

OPERATION

The LMLS-500 operates on Class 2 power supplied to a DLM local network by one or more DLM room controllers. Daylighting loads are assigned using an LMCT-100-2 wireless configuration tool. Following a quick initial setup, the LMLS-500 monitors the daylight contribution through a window or skylight and works with the room controller(s) to maintain design light levels in each lighting zone. Wattstopper's exclusive control algorithm uses on/off or dimming setpoints and other control parameters to establish the correct light levels throughout the day regardless of changing daylight contribution.

FEATURES

- Digital Lighting Management components plug together on a free-topology Cat 5e DLM local network
- Test mode override of programmed time delay allows easy verification of selected settings
- Load status verification allows confirmation and testing of controlled load
- Compatible with DLM wall switches for manual override, if desired
- Infrared (IR) transceiver for wireless configuration and control
- LED status indicators
- Mounting options for toplit or sidelit applications
- Complies with California Title 24, Section 119 requirements
- The product meets the materials restrictions of RoHS
- BAA/BABA-compliant models available

SIMPLIFIED SETUP AND CONFIGURATION

The LMLS-500 is set up by entering the daylight and the workplane illuminance into an LMCT-100-2 wireless configuration tool. This handheld device then automates the calibration process, and recommends setpoints for easy completion of the setup process. The LMCT-100-2 may be used to adjust setpoints and other parameters including hold off functionality. Adjustable switching parameters include on and off setpoints and time delays. The off setpoint can be adjusted to a value of 25, 50 (default), 75, or 100 percent above the on setpoint. Adjustable dimming parameters include a setpoint, ramp up and down rates and a cut-off time delay. Electric lights can be turned off (default) or dimmed to a user-selectable minimum level when daylight contribution is abundant.

APPLICATIONS

The LMLS-500 photosensor is recommended for open offices, cafeterias, classrooms, warehouses and any other indoor spaces with daylight contribution. It is designed to measure only daylight, not electric light, and can be mounted in a light well under a skylight, or on a ceiling for sidelighting applications. Each of the three control zones can initiate on/off switching, bi-level or tri-level step switching or step dimming, or continuous dimming.

PROJECT

LOCATION/
TYPE

SPECIFICATIONS

- Input voltage: 24VDC from DLM local network
- Current consumption: 7mA
- DLM local network connection: 1 RJ45 port
- Digital multi-band photodiode with extended range: 1-1,500 fc (10-16,145 lux)
- Spatial response: 60°
- LED status and configuration indicators
- Infrared (IR) transceiver
- Weight: 1.4 oz (40 g)
- Operating conditions: for indoor use only; 32-131°F (0-55°C); less than 90% RH, non-condensing
- UL and cUL listed
- FCC part 15 compliant
- Five year warranty

DIMENSIONS & MOUNTING

Product Dimensions

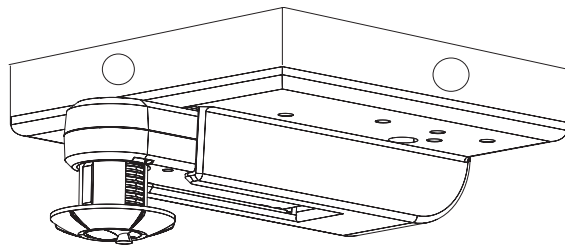
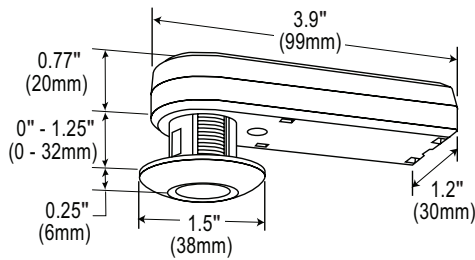

Mount to J-box with LMLS-MB1 bracket

Mounting

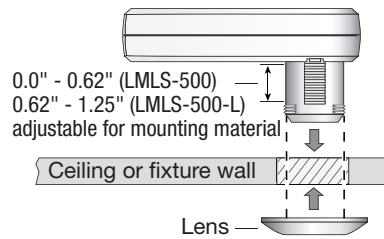

Mount in Ceiling

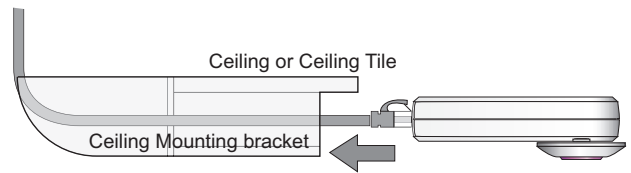

Mount to Ceiling with LMLS-MB2 bracket

PLACEMENT

Sidelight Applications

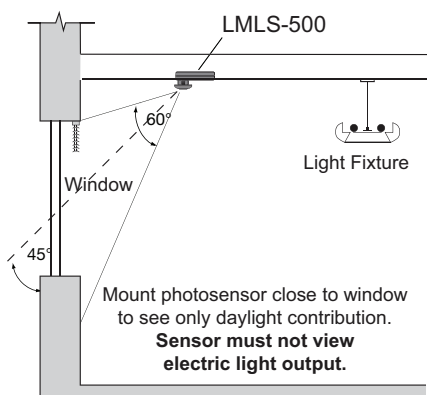

Skylight Applications

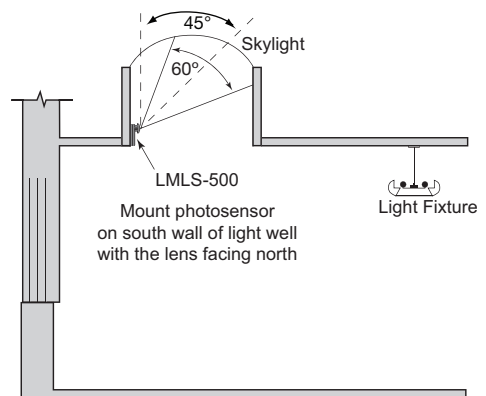

PHOTODIODE RESPONSE

Spectral Response

The photodiode detects just visible light, which ensures accurate lighting control.

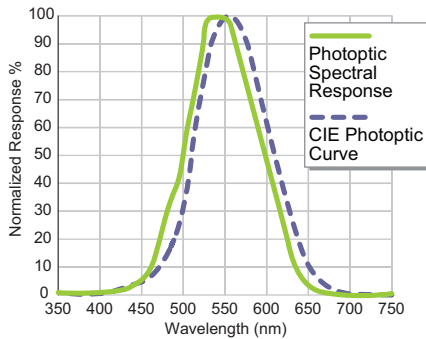

Spatial Response

Focused response allows detection of daylight only.

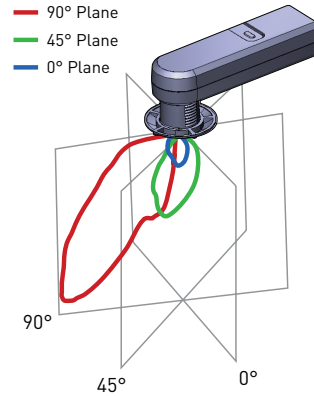

CONNECTING

Sample Connection Diagram for Three Zone On/Off Switching Application

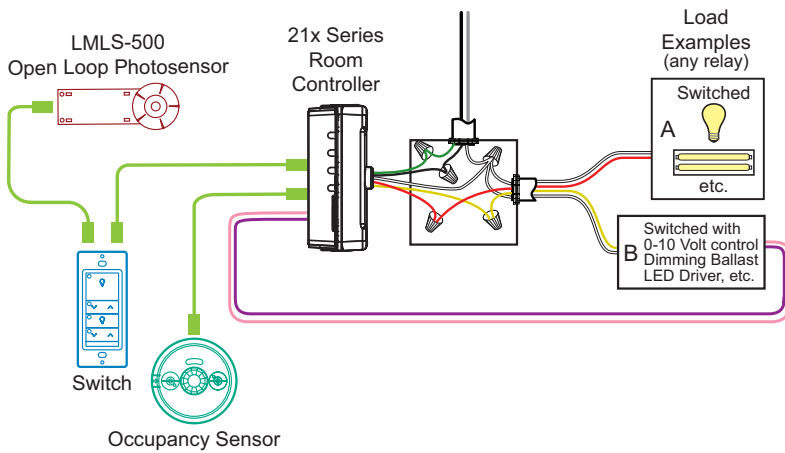

Plug DLM local network components together in any configuration using Cat 5e cables with RJ45 connectors.

ORDERING INFORMATION

Catalog #	Description
<input type="checkbox"/> LMLS-500	Digital Multiple Zone On/Off and Dimming Open Loop Photosensor
<input type="checkbox"/> LMLS-500-U	Digital Multiple Zone On/Off and Dimming Open Loop Photosensor, BAA/BABA compliant*
<input type="checkbox"/> LMLS-500-L	Digital Multiple Zone On/Off and Dimming Open Loop Photosensor with extended tube,
<input type="checkbox"/> LMLS-500-L-U	Digital Multiple Zone On/Off and Dimming Open Loop Photosensor with extended tube, BAA/BABA compliant*
<input type="checkbox"/> LMLS-MB1	Photosensor mounting bracket for J-box mounting
<input type="checkbox"/> LMLS-MB2	Photosensor mounting bracket for wall mount applications
<input type="checkbox"/> LMCT-100-2	Digital Wireless Configuration Tool with USB
<input type="checkbox"/> LMCT-100-2-U	Digital Wireless Configuration Tool with USB, BAA/BABA compliant*

*Product is compliant with the Buy American Act and Build America, Buy America Act