

Catalog Number • Numéro de Catalogue • Número de Catálogo: LMDM-601

Country of Origin: Made in China • Pays d'origine: Fabriqué en Chine • País de origen: Hecho en China

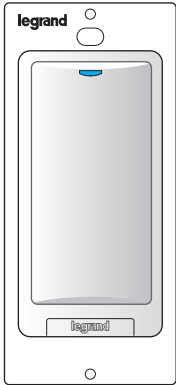

Once paired to an LMRC-611 wireless room controller or LMBC-650 wireless bridge, this unit is set for Plug n' Go operation, adjustment via the DLM Configuration App is recommended to meet the local energy code where installed.

The DLM Wireless 1-Button dimmer switch is a wireless battery powered wall switch intended for operation with wireless room controllers.

Do not apply cleaning solvent directly onto unit. Apply cleaning solvent onto a cloth, then wipe the unit to clean it.

NOTE: Installation shall be in accordance with all applicable regulations, local, and NEC codes

INSTALLING THE BUTTON

The LMDM-601-W (White) ships with the button installed. All other switch colors ship with our quick install button kit. To install:

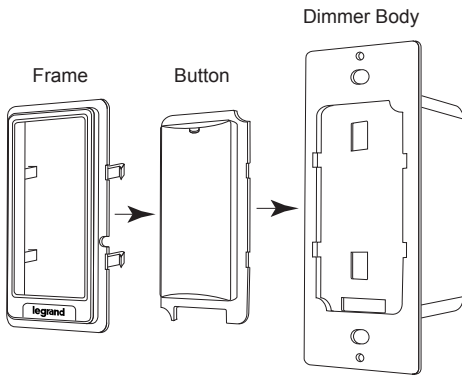

Place button into Body, then snap-on frame, pressing down till tabs click.

INSTALLING THE SWITCH

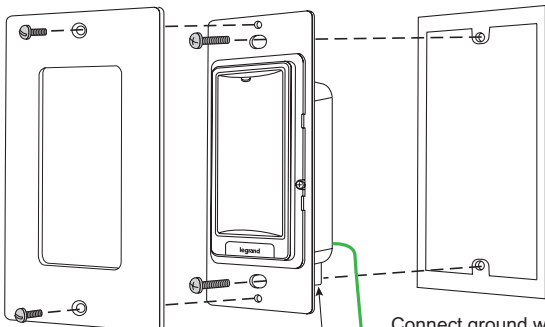

Pull to remove battery protection tab before use. Connect ground wire if installing next to Class 1 power. If not, there is no need to connect the ground wire (please comply with local code).

SPECIFICATIONS

- Power Supply Battery powered, CR123A Lithium Ion, 3 VDC
- Connection to DLM Network..... Wireless via LMRC-611 room controllers or LMBC-650
- Wireless Radio Single, Concurrent 802.15.4 andBluetooth Low Energy, 2.4GHz
- Wireless Communication
 - IPv6 Mesh (6LoWPAN) Range..... up to 60 ft.
 - Bluetooth low energy Range up to 30 ft.
 - 60 ft. max. between LMDM-601 and room controller or bridge
- Wireless Encryption.....AES-128 bit symmetric key
- Environment For Indoor Use Only
 - Operating Temperature 32° to 104°F (0° to 40°C)
 - Storage Temperature 23° to 140°F (-5° to 60°C)
 - Relative Humidity 5 to 95% (non condensing)
- Compliance/Regulatory
 - FCC, RoHS,
 - Bluetooth certified
 - UL and cUL listed (E101196)
- Patent Pending

BUTTONS AND INDICATORS

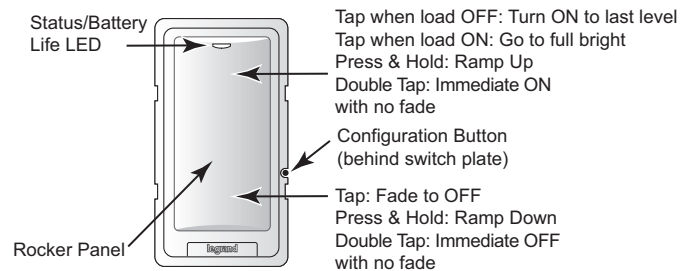

LED Color	Function
White	Unit Boot Up
Green, 1 Blink	Config Button Pressed
Blinking Green	Push to Pair Mode
Red, 1 Blink	In normal operation, if any button press, indicates low battery Also blinks if Reset button on back is pressed
Blinking Red	Push n' Learn Mode
Blue	Paddle pressed during normal operation

WIRELESS ROOM CONNECTION

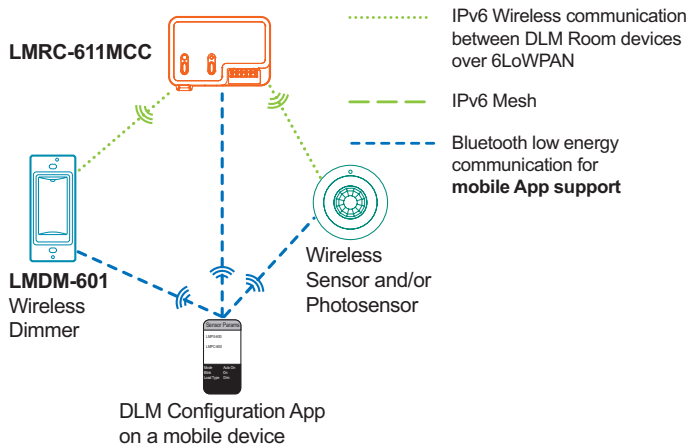

Distance Recommendations:

- 30' max between LMDM-601 and mobile device
- 60' max. between LMDM-601 and room controller or bridge

HYBRID ROOM CONNECTION

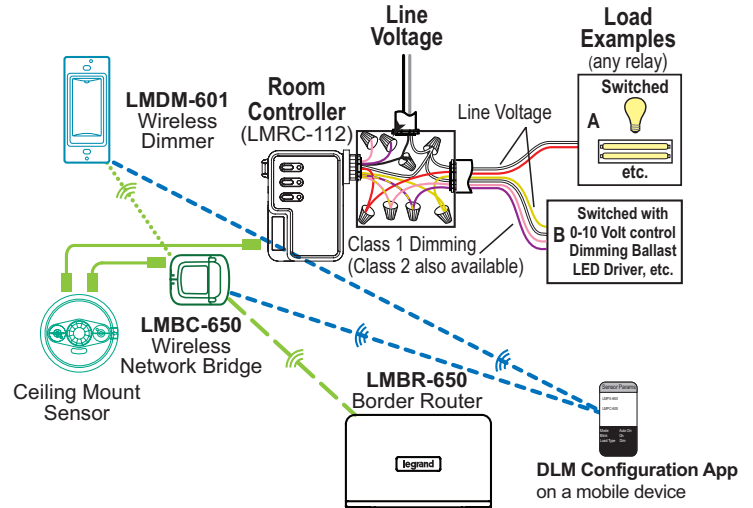

- Note:** For a single (non-networked) hybrid room, the LMBR-650 is not required.
- Note:** The DLM Config App can only connect with the LMBC-650 to update firmware or pair devices. You need an LMBR-650 and LMCS to commission a Hybrid room. For a single room, without an LMBR-650, LMCS can connect to the LMBC-650 via the LMCI.

IMPORTANT INSTALLATION INFORMATION

To ensure a successful installation and startup of a wireless system, the following steps must be taken by the installing contractor. **Failure to document all device address and locations may delay completion of startup and result in additional startup charges.**

Key Requirement: Document **every** Device's MAC Address (at least the last 4 alphanumeric characters). An additional MAC address label is included for the installer to use on a floor plan map. The last four characters are repeated in a larger font, in bold. Keep this document so that the commissioning tech has access at a later date.



Examples of labels

SETTING UP A ROOM NETWORK BY PAIRING DEVICES

Pair wireless devices to a room controller to create an individual room network and enable Plug N' Go operation.

Device pairing can be done by using Push-to-Pair (PtP) mode on the room controller and all other wireless devices, or by using the DLM Config App.

To pair devices in a network, they must all have the same wireless channel and Network ID. By default the channel is 15 and the Network ID is 1. Using Push-to-Pair mode, the Network ID for all devices being paired is migrated to a new number, so that only those device communicate with each other. The channel number will remain at 15.

DEVICE PAIRING USING PUSH-TO-PAIR MODE

Push-to-Pair in a room with a single LMRC-611 Room Controller

NOTE: Once you enter PtP mode on the room controller, a three minute timer begins. If the Config button on any device in the room is pressed, the timer resets and begins the three minute countdown again. If no Config button is pressed within three minutes, the room controller will exit PtP mode.

1. **Enter PtP mode on the room controller.** Press the Config button three times (within three seconds) until the LED on the room controller flashes green.
2. **Enter PtP mode on the LMDM-601.** Using a pointed tool, press the Config button three times. As with the room controller, the LED on the switch will flash green.
3. **Pair the LMDM-601.** Press the Config button on the LMDM-601 one more time to pair it to the room controller. The load connected to the room controller will toggle once (if the load is OFF, it will turn ON; if ON, it will turn OFF) to indicate that pairing was successful. Also, the LMDM-601's blinking LED will turn to solid green as another indicator of a successful pairing.

NOTE: If there are any wireless sensors, dimmers, or additional switches in the room, repeat steps 2 and 3 for each of those devices so that all devices are paired together in the same network. For each device, the load will toggle during step 3 and its config LED will turn solid green.

4. **Exit PtP mode.** From any device, press the Config button 3 times. After a few seconds, the LED on each Room controller, switch or sensor currently in PtP mode will flash white and reboot, leaving the default network and migrating to the new network. Then, the LED on the room controller will flash blue and the pairing process finishes. The default Network ID on all devices will change to a new number, based on the last four digits of the Mac address on the room controller, and now those devices will communicate only with each other and not any devices which have not been paired.

NOTE: It is important to exit PtP mode within the three minute time limit mentioned above. If you do not, none of the device pairings will be remembered and you have to start the process over from the beginning.

Push-to-Pair in a room with multiple LMRC-611s

In a room with multiple loads, there may be more than one LMRC-611. They can all be paired to the same room network, allowing the scene switch to set each load to different levels per scene. One of the room controllers will become the primary, determining the Network ID and channel settings for all the devices in the network.

1. **Enter wireless Push-to-Pair (PtP) mode on all room controllers.** Press the Config button three times on each LMRC-611 to put them all in PtP mode. The green LEDs will flash on all room controllers. The **first** room controller placed into PtP will become the **primary**.
2. **Pair the room controllers together.** Press the Config button one more time on each room controller **except** for the primary. This indicates to the rooms controllers that they will be paired with each other.

The primary room controller's LED blink rate will double once the first device is paired to it. This faster blink rate is convenient when multiple room controllers are present on the same network. The LED will turn solid on the other controllers being paired.

NOTE: If there are more than two room controllers, you have the choice of either placing them all in PtP mode and then pairing them, or pairing the first two controllers and then repeating steps 1 and 2 for each additional controller, leaving the primary controller in PtP mode the entire time.

3. **Enter PtP mode on the LMDM-601.** Using a pointed tool, press the Config button three times. As with the room controller, the LED on the switch will flash green. Also, the LMDM-601's blinking LED will turn to solid green as another indicator of a successful pairing.
4. **Pair the LMDM-601.** Press the Config button on the LMDM-601 one more time to pair it to the room controllers. The loads connected to the room controllers will toggle once (if the load is OFF, it will turn ON; if ON, it will turn OFF) to indicate that pairing was successful.

NOTE: If there are any wireless sensors, dimmers, or additional switches in the room, repeat steps 3 and 4 for each of those devices so that all devices are paired together in the same network. For each device, the load will toggle during step 4.

5. **Exit PtP mode.** From any device, press the Config button 3 times. After a few seconds, the LED on each Room controller, switch or sensor currently in PtP mode will flash white and reboot, leaving the default network and migrating to the new network. Then, the LED on the room controller will flash blue and the pairing process finishes. The default Network ID on all devices will change to a new number, based on the last four digits of the Mac address on the primary room controller, and now those devices will communicate only with each other and not any devices which have not been paired.

NOTE: It is important to exit PtP mode within the three minute time limit mentioned above. If you do not, none of the device pairings will be remembered and you have to start the process over from the beginning.

Pairing a device to an existing network

If you need to add the LMDM-601 to an existing in room network, follow the procedure below:

1. **Enter wireless Push-to-Pair (PtP) mode on the room controller or any currently paired battery device.** Press the Config button three times (within three seconds). The LED on the room controller and any paired battery devices that are currently awake will flash green.
2. **Enter PtP mode on the LMDM-601.** Using a pointed tool, press the Config button three times. As with the room controller, the LED on the switch will flash green.
3. **Pair the devices.** Press the Config button on the LMDM-601 one more time to pair the LMDM-601 to the room controller. The load connected to the room controller will toggle once (if the load is OFF, it will turn ON; if ON, it will turn OFF) to indicate that pairing was successful and its config LED will turn solid green.
4. **Exit PtP mode.** From any device, press the Config button 3 times. After a few seconds, the LED on the LMDM-601 will flash white and reboot, leaving the default network and migrating to the new network. Then the LED on the room controller will flash blue while it completes the pairing process. The Network ID of the LMDM-601 will change to the value used by the previously paired devices and the room controller also returns to that value.

DEVICE PAIRING AND UNIT ADJUSTMENT USING THE DLM CONFIG APP

The DLM Config App is available for both iOS® and Android® devices. Search "DLM Config" on your device to download.

The app provides the ability to pair various devices in a room. Additionally, you can modify load binding and edit various DLM parameters for each device.

For details on the features and operation, download the DLM Config App User Guide from the wattstopper web site at :

<https://www.legrand.us/wattstopper/software>



PLUG N' GO OPERATION (PNG)

All loads are automatically bound to the LMDM-601.

The rocker paddle on the LMDM-601 controls all loads on the DLM Local Network. Tap the top of the rocker to turn ON all loads to the last light level. Tap the bottom to turn OFF all loads. Dimmable loads dim (ramp down or up) in response to a press and hold of the appropriate portion of the rocker paddle. Switched loads turn OFF when ramped down below 50% and turn ON when ramped up above 50%.

UNIT ADJUSTMENT USING PUSH N' LEARN

NOTE: Although Push n' Learn™ can be used to modify load binding for wireless switches, Wattstopper recommend using the DLM Config App for ease of use and available features.

Load Selection Procedure

In situations in which there is more than one load in a room, the configuration button allows access to Push n' Learn™ technology to change the binding relationship between control devices and loads.

NOTE: PnL cannot be used to change the binding on wireless sensors, although it is possible to enter PnL mode from a sensor.

Step 1 Enter Push n' Learn

Press and hold the Config button (on any DLM device) for 3 seconds.

The LED on the LMDM-601 begins to blink red. The LED on all switches and sensors, and the Config LED on room controllers in the local room network will also blink red. The LEDs will continue to blink until you exit PnL mode.

NOTE: If a switch or sensor is currently "asleep", it will not blink. To ensure the switch is currently awake before initiating PnL, press a button first, or initiate PnL from that switch.

All loads in the room turn OFF immediately after entering PnL, then one load will turn ON. This is Load #1. On the LMRC-611 for that load, the blue Load LED will also be ON.

Step 2 Load selection

Press and release the Config button to step through the loads connected to the DLM Local Network. Each time you press the Config button, the next load in the series will turn ON along with its Load LED, and the previous load will turn OFF.

To view the current status of the button or paddle, press the button or paddle once. The LED on the paddle will blink once blue or red, and then revert to blinking red. To bind or unbind a button or paddle from the load press **and hold** that button or paddle on the LMSW-605 or LMDM-601. The LED will switch to the other color and stay lit for one second and then resume blinking red. Each time you press and hold the paddle or button, it will cycle to the next option:

- **Blue** – The button or paddle is bound to the load.
- **Red** – The button or paddle is not bound to the load.

Step 3 Exit Push n' Learn

Press and hold the Config button until the red LED turns OFF, approximately 3 seconds.

RESETTING THE LMDM-601

When you reset the LMDM-601, the Channel and Network ID will return to their default values, and if the switch was previously paired, it will no longer be connected to that room network. All DLM parameters are also returned to their default values.

There are two ways to reset the LMDM-601:

- Press the Config button (behind the wall plate) 10 times. The LED will blink green each time the Config button is pressed (except for the 7th press which will blink blue). On the 10th press, the LED will blink red. Then it will turn red again and then briefly turn white indicating it is rebooting.
- Remove the battery cover on the back to expose the recessed reset button. Use a paper clip to press and hold the reset button for 10 seconds. When you first press the reset button, the LED will blink red once, then after the 10 seconds will reboot and the LED will briefly turn white, indicating it is rebooting.

NOTE: You can also reset the LMDM-601 from the DLM Config App (the LMDM-601 must be woken up before resetting).

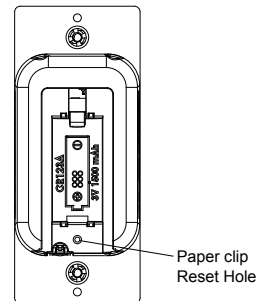

FCC REGULATORY STATEMENTS

This device complies with part 15 of the FCC Rules. Operation is subject to the following two conditions: (1) This device may not cause harmful interference, and (2) this device must accept any interference received, including interference that may cause undesired operation.

NOTE: This equipment has been tested and found to comply with the limits for a Class B digital device, pursuant to part 15 of the FCC Rules. These limits are designed to provide reasonable protection against harmful interference in a residential installation.

This equipment generates uses and can radiate radio frequency energy and, if not installed and used in accordance with the instructions, may cause harmful interference to radio communications. However, there is no guarantee that interference will not occur in a particular installation. If this equipment does cause harmful interference to radio or television reception, which can be determined by turning the equipment off and on, the user is encouraged to try to correct the interference by one or more of the following measures:

- Reorient or relocate the receiving antenna.
- Increase the separation between the equipment and receiver.
- Connect the equipment into an outlet on a circuit different from that to which the receiver is connected.
- Consult the dealer or an experienced radio/TV technician for help.

RF exposure warning

This equipment complies with FCC radiation exposure limits set forth for an uncontrolled environment. At least 20 cm of separation distance between this device and the user's body must be maintained at all times.

Any changes or modifications not expressly approved by The Watt Stopper Inc. could void the user's authority to operate the equipment.

IC Caution:

This device complies with Industry Canada license-exempt RSS standard(s). Operation is subject to the following two conditions:

- (1) This device may not cause interference, and
- (2) This device must accept any interference, including interference that may cause undesired operation of the device.

Le présent appareil est conforme aux CNR d'Industrie Canada applicables aux appareils radio exempts de licence. L'exploitation est autorisée aux deux conditions suivantes:

- (1) l'appareil ne doit pas produire de brouillage, et
- (2) l'utilisateur de l'appareil doit accepter tout brouillage radioélectrique subi, même si le brouillage est susceptible d'en compromettre le fonctionnement.

RF exposure warning

This equipment complies with IC radiation exposure limits set forth for an uncontrolled environment. This equipment should be installed and operated with minimum distance 20cm between the radiator & your body.

Cet équipement est conforme aux limites d'exposition aux radiations de la IC définies pour un environnement non contrôlé. Cet équipement doit être installé et utilisé à une distance minimale de 20 cm entre le radiateur et votre corps.

NOTE: No rights or licenses under patents owned or controlled by third parties, express or implied, are granted to use third-party devices in combination with these products in a wireless mesh network, or to use third-party services to access, monitor or control these products in a wireless mesh network via the internet or another external wide area network. Separate license rights may need to be obtained from such third parties for such devices, combinations and services.

WARRANTY INFORMATION

Wattstopper warrants its products to be free of defects in materials and workmanship for a period of five (5) years. There are no obligations or liabilities on the part of Wattstopper for consequential damages arising out of, or in connection with, the use or performance of this product or other indirect damages with respect to loss of property, revenue or profit, or cost of removal, installation or reinstallation.

INFORMATIONS RELATIVES À LA GARANTIE

Wattstopper garantit que ses produits sont exempts de défauts de matériaux et de fabrication pour une période de cinq (5) ans. Wattstopper ne peut être tenu responsable de tout dommage consécutif causé par ou lié à l'utilisation ou à la performance de ce produit ou tout autre dommage indirect lié à la perte de propriété, de revenus, ou de profits, ou aux coûts d'enlèvement, d'installation ou de réinstallation.

INFORMACIÓN DE LA GARANTÍA

Wattstopper garantiza que sus productos están libres de defectos en materiales y mano de obra por un período de cinco (5) años. No existen obligaciones ni responsabilidades por parte de Wattstopper por daños consecuentes que se deriven o estén relacionados con el uso o el rendimiento de este producto u otros daños indirectos con respecto a la pérdida de propiedad, renta o ganancias, o al costo de extracción, instalación o reinstalación.