

# PLUG LOAD CONTROLLER

LMPL-111-20M

Plenum-rated controller with line voltage relay and intelligent switching power supply

Knockout mounting for easy installation

Advanced real time metering of voltage and current (+/- 2% accuracy)

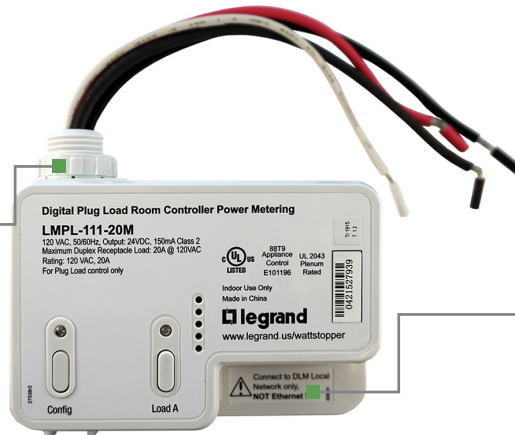

Plug n' Go™ automatic configuration for quick installation and maximum energy efficiency

Accepts occupancy sensor signal or schedule events for energy saving control of plug load

Plugs to other components using Cat 5e cable and RJ45 connectors eliminating wiring errors

## DESCRIPTION

The LMPL-111-20M Plug Load Controller contains a 20 amp relay for on/ off control of connected outlets, and a high-efficiency intelligent switching power supply. This plug load controller works as part of the Wattstopper Digital Lighting Management (DLM) system and enables energy-efficient control of plug loads.

## OPERATION

LMPL-111-20M Plug Load Controllers operate on 120 volts and provide Class 2 power to sensors and switches via the DLM local network. Once powered up, Plug n' Go automatically configures system components for the most energy-efficient operation. The plug load controller switches controlled outlets on and off in response to input from any communicating occupancy sensors. The DLM system may be reconfigured using Push n' Learn without the need for tools or a PC.

## PLUG N' GO AUTOMATIC CONFIGURATION

Plug n' Go automatic configuration establishes system functionality based on the installed components. If present, Plug Load Controllers are initially controlled by all the occupancy

sensors on the DLM local network, and default to automatic on/off operation whether there is a switch on the local network or not. DLM system operation may be reconfigured using Push n' Learn. As an example, a selected switch button may be bound to a plug load controller and it's operation changed to manual-off control of outlets. Similarly, the plug load controller could be bound only to selected occupancy sensors, or controlled by a schedule (if a system timeclock is present).

## APPLICATIONS

LMPL-111-20M Plug Load Controllers should be installed so they control outlets used for task lighting and non-essential equipment in private offices, open offices, lunch rooms and break rooms and other areas in commercial buildings. They are appropriate for LEED projects and help building owners realize a higher return on investment on energy code-required occupancy sensors. They are also ideal for facility managers who want to track building power usage. A network bridge, either wireless or wired (LMBC-650 or LMBC-300), is required to expose DLM local network power data readings to a Segment Manager or LMBR-650 Border Router, so they can be shared with a BAS.

## FEATURES

- Knockout mounting for easy installation
- Advanced real time metering of voltage and current (+/- 2% accuracy)
- Plug n' Go™ automatic configuration for quick installation and maximum energy savings
- Push n' Learn™ functionality for personalization without the need for tools or a PC
- Load On/Off local override button
- LED indicates status of connected load
- Digital Lighting Management components plug together on a free-topology Cat 5e DLM local network
- Integral current monitoring of connected load
- 2 RJ45 ports with integral strain relief and hinged dust cover
- Zero-crossing circuitry for reliability and increased product life
- UL2043 plenum rated
- The product meets the materials restrictions of RoHS
- BAA/BABA-compliant model available

PROJECT		LOCATION/ TYPE	
---------	--	-------------------	--

## SPECIFICATIONS

- Voltage: 120VAC; 50/60Hz
- Load ratings:
  - Ballast or incandescent: 20A
  - Motor load: 1Hp
- DLM local network parameters:
  - Maximum current: 800mA
  - Maximum cable (Cat5e): 150' per intelligent device on local DLM network, up to 1,000' max.
  - Up to 64 loads
  - Communicating Device Limitation:
    - When all power supplies are 10X-Series: 24 Devices.
    - When other power supplies are present: 48 Devices.
  - Maximum of (5) 10X-Series power supplies (LMRC-10X, LMPL-101, LMPB-100) per local network.
- Class 2 output to DLM local network: 24VDC. In VDC, intelligently provides 150mA across 2 RJ45 ports (communicates with other DLM load controllers to avoid exceeding max mA allowed)
- Operating conditions: for indoor use only; 32-131°F (0-55°C); 5-95% RH, non-condensing
- UL and cUL listed
- FCC part 15 compliant
- Five year warranty

## CONTROLS & MOUNTING

### Controls and Dimensions

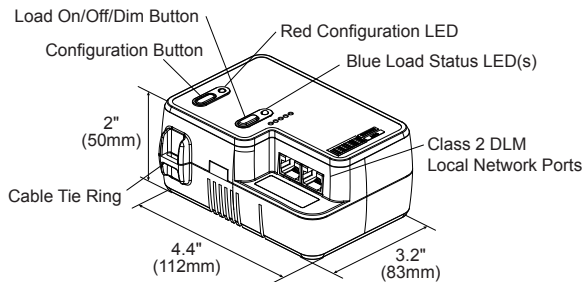

### Mounting

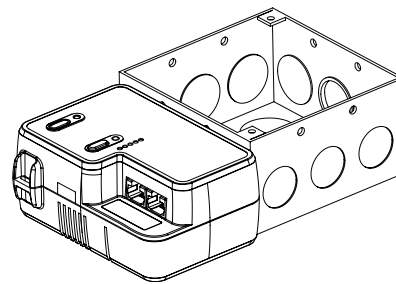

Mount to 1/2" KO on a deep J-box

## SAMPLE CONNECTION AND WIRING DIAGRAM

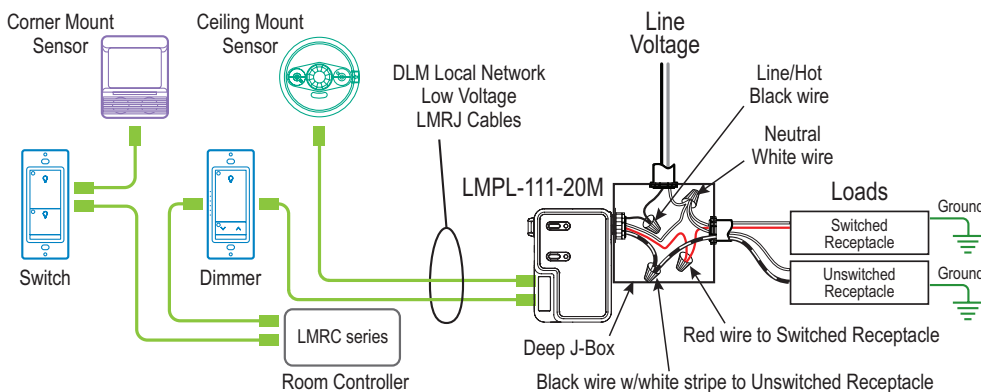

Plug DLM local network together in any configuration using Cat 5e cables with RJ45 connectors.

## ORDERING INFORMATION

			Load Rating			
Catalog #	Description	Single Phase Voltage 50/60Hz	Ballast	Incan	Motor	Class 2 Outputs
<input type="checkbox"/> LMPL-111-20M	Plug Load Controller	120VAC; 50/60Hz	20A	20A	1 Hp	24 VDC; 150 mA
<input type="checkbox"/> LMPL-111-20M-U	Plug Load Controller, BAA/BABA compliant*					
<input type="checkbox"/> LMCT-100-2	Digital Wireless Configuration Tool					
<input type="checkbox"/> LMCT-100-2-U	Digital Wireless Configuration Tool, BAA/BABA compliant*					

\*Product is compliant with the Buy American Act and Build America, Buy America Act