



Wattstopper®

Lighting Control Panel

Installation Instructions and Wiring Reference

No: 24278 – 08/25 rev. 3

Catalog Number: LP8

Country of Origin: Made in United States

BAA/TAA Compliant



SPECIFICATIONS

- Supply Voltages.....per selected power supply
 - P115/277 Power Supply115 or 277VAC
 - P115/347 Power Supply115 or 347VAC
 - Load Ratings
 - @120VAC, 50/60Hz20A Tungsten or Ballast
 - @277/347VAC, 50/60Hz20A Ballast
 - @250VAC1HP
 - Accessory Power Output..... 800mA @24VDC/VAC/ACR
 - Environmental
 - Maximum Ambient Temperature60°C
 - Maximum Humidity 5% to 90% RH, non-condensing
- UL & CUL Listed for receptacle rated circuit control.

DESCRIPTION AND OPERATION

The LP panels contain up to 8 relays controlling lighting through automatic scenarios, time schedules, photocells and occupant controlled switches. Scheduling capability is included through a built-in clock with a keypad and display window on the interior. The interior provides isolation between the line- and low-voltage sections of the panel, as well as the mounting frame for relays, the power supply and the circuit board assemblies.

LP panels are shipped with all their components installed in a locking enclosure. The LP8's enclosure is compact, measuring only 16.5" x 15.1". A secure outer cover protects the user from the high voltage area. A separate interior enclosure protects the low voltage wiring and components while allowing easy user access to the time clock scheduling controls.

If you have any questions, call technical support at: 888.852.2778. Use the plastic sleeve affixed inside the enclosure cover door to keep these instructions and the completed system documentation forms for future reference.

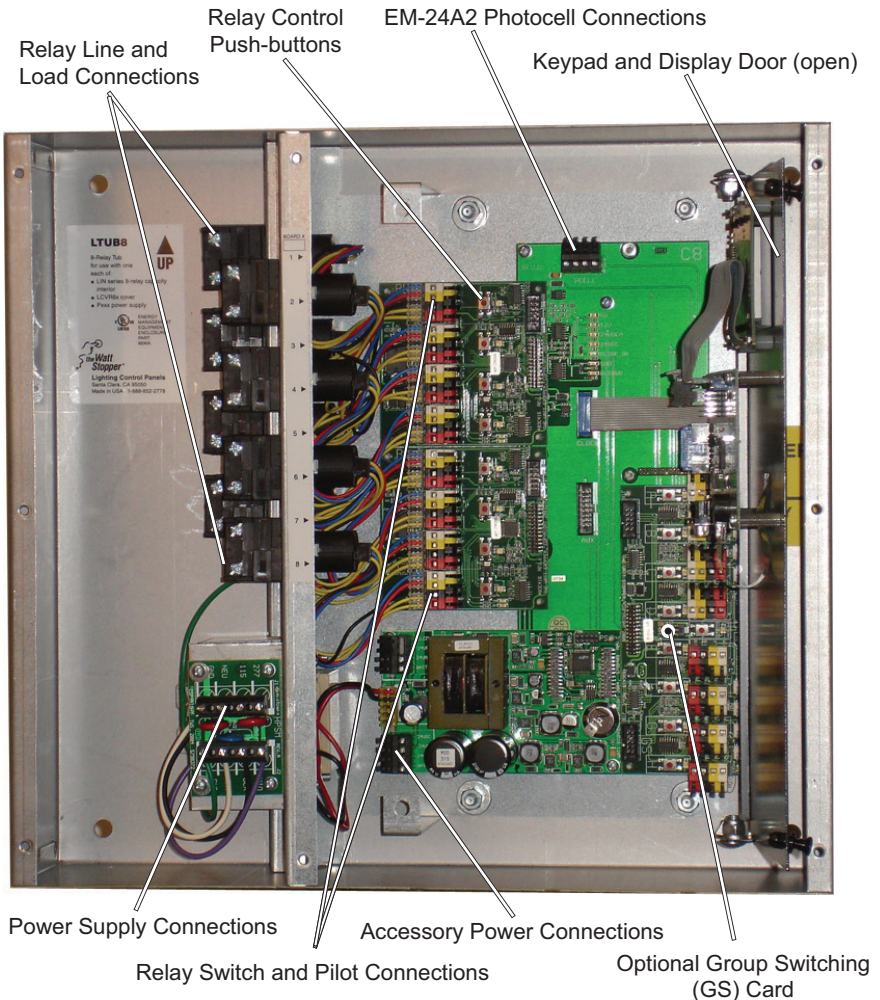

**Figure 1: LP8 Components
(enclosure cover removed and interior keypad and display door open)**

INSTALLATION

Some of the procedures in this manual may have been previously completed using the **LP8 Quick Start Installation Guide**. The instructions that follow contain additional details about the installation that may be useful in particular applications. These instructions also provide information about installing optional equipment.



WARNING: TURN THE POWER OFF AT THE CIRCUIT BREAKER BEFORE WIRING.



General Installation Information

- All power must be turned off prior to wiring, installation or service.
- More than one disconnect may be required to de-energize power to the LP8.
- External circuit protection to the LP8 is required (such as a circuit breaker).
- Installation shall be in accordance with all applicable regulations, wiring practices, and codes.
- Care should be taken to separate high voltage power from low voltage (Class 2) control wiring.
- Do not energize wiring until the unit is fully assembled and connected circuits have been tested and found to be free of electrical shorts.



WARNING: IMPROPER INSTALLATION OR CONNECTION OF THE LP8 MAY RESULT IN SERIOUS PERSONAL INJURY AND/OR DAMAGE TO THE LP8 AND OTHER DEVICES.



Mount the Enclosure

1. Place the LP on a sturdy, flat, horizontal surface.
2. Locate and remove the outer cover and set aside.
3. Open the interior door containing the clock keypad and display window by pulling up the two black plastic self-retained pop-fasteners on the left side.
4. Remove the panel interior assembly.
 - a. Remove the serrated flanged nut that attaches the transformer mounting assembly to the back of the enclosure.
 - b. Remove the four sets of serrated flanged nuts that attach the interior assembly to the back of the enclosure.
 - c. Close the interior door and press down on the two black plastic self-retained pop-fasteners on the left side to lock the door.
 - d. Lift the entire interior assembly out of the enclosure and set it aside. Keep the hardware in a safe place until all rough-in conduit and wiring is completed.
5. Attach the enclosure to the wall. The enclosure should be level, plumb and rigidly installed with hardware sufficient to hold 100 pounds (46kg) minimum.
6. Determine the appropriate wire entry locations. Make sure that all line and low voltage wiring entry locations are confined to the appropriate compartments as shown in Figure 2 or 2a as appropriate.

Do not run low voltage wiring with line voltage or power wiring.
7. Drill or knock out openings to bring wiring conduit into the enclosure.

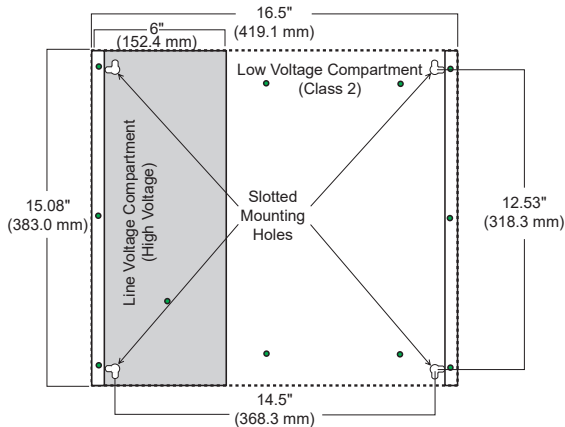

Figure 3: LP8 Enclosure dimensions, mounting holes, location of line and low voltage wiring compartments.

Install Interior

Do not reinstall the interior until after the exterior enclosure has been securely mounted to the wall and the conduit/wiring holes have been drilled or knocked out.

1. Place the interior in the enclosure.
2. Align the interior with the studs provided in the enclosure.
3. Hold the interior in place while you pull up on the black self-retaining pop-fasteners to open the door.
4. Install the four serrated flanged nuts that attached the interior assembly to the back of the enclosure
5. Secure the transformer mounting assembly to the back of the enclosure using a serrated flange nut.
6. Close the interior door and push in the pop-fasteners.
7. Install panel cover to enclosure using the cover screws provided.

CONNECT THE LP8 POWER SUPPLY

The LP8 has several power supply options that allow it to operate with 115VAC, 277VAC, or 347VAC line voltage. These power supplies function with either 50 or 60 Hz. They have internal overcurrent protection. The transformer automatically turns off when overloaded and resets when the fault is removed. The power supply contains MOVs to protect all downstream electronics from powerline voltage spikes.

1. Read and remove the CAUTION label covering the terminals.
2. Note that there are different terminals for supply voltage input. Wire to **only one** of these terminals. Match your input voltage to the correct terminal.

CAUTION

⚡ VERIFY WHETHER YOUR SUPPLY LINE VOLTAGE IS 115VAC, 277VAC, OR 347VAC AND THAT THE POWER SUPPLY IN THE LP8 MATCHES THAT LINE VOLTAGE. WIRING TO THE INCORRECT VOLTAGE TERMINAL MAY RESULT IN DAMAGE TO THE POWER SUPPLY AND/OR THE PANEL, AND WILL VOID THE PRODUCT WARRANTY. ⚡

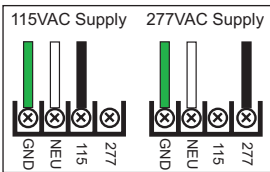

Figure 5: P115/277 wiring

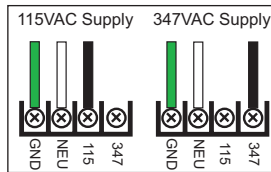

Figure 6: P115/347 wiring

CONNECT LINE VOLTAGE

Before making any connections to the relays, make sure that none of the load circuits are shorted. Wire from the circuit breaker through each relay's SPST output terminals, and from there to the loads. Confirm that each circuit is wired to the relay specified in the electrical construction drawings.

Power Up and Test Relays

1. Apply power to the LP8 power supply **ONLY**. **Do NOT apply power to the controlled circuit loads.**
2. As shown in the illustration, press the Relay Control Button next to each relay's yellow plug-in terminal to toggle it on/off. The relay should "click" and its LED indicator should change state.
3. Confirm the operation by measuring the continuity at the line voltage terminations of each relay.
4. Apply power to the relays.
5. Being careful not to touch any line voltage wiring, toggle each relay on/off again and confirm that each relay controls the appropriate load.

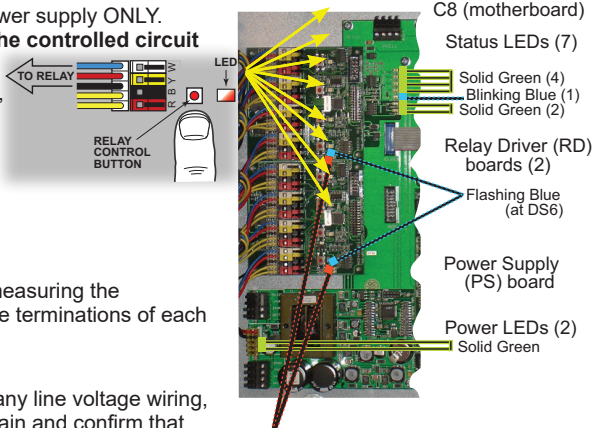

Blinking Amber on RD board (at DS7) = trouble condition

Figure 8: Relay Control Buttons & Status LEDs

Confirm Nominal Operation

With power applied to the LP8 panel, there should be two (2) green LED indicators glowing on the power supply card in the lower left corner of the panel. And, there should be six (6) green LED indicators glowing at the top of the panel below the EM24A2 photocell connector. A single (1) blue LED in this group blinks approximately once per second indicating normal operation.

Each relay driver card (2 cards for 8 relays) has a blue LED that should flash randomly. The group switching card (optional) also has two (2) blue LEDs that flash randomly during normal operation.

If you are having problems with your LP8, please note the condition of all the LEDs before calling Wattstopper technical support.

LOW VOLTAGE WIRING

Open the interior door to access the connectors in the low voltage section. All input/output wiring in this section must be low voltage, Class 2 wiring. Do not use the low voltage wiring compartment as a raceway or junction box. Refer to local codes regarding Class 2 wiring practices.

Hardwire Low Voltage Switches (Optional)

LP panels include a switch input for each relay. These accept any of the dry-contact configurations shown below. Operation of the switch will turn on/off the corresponding relay.

To control multiple relays from a single input device, we recommend using the optional Group Switching Card.

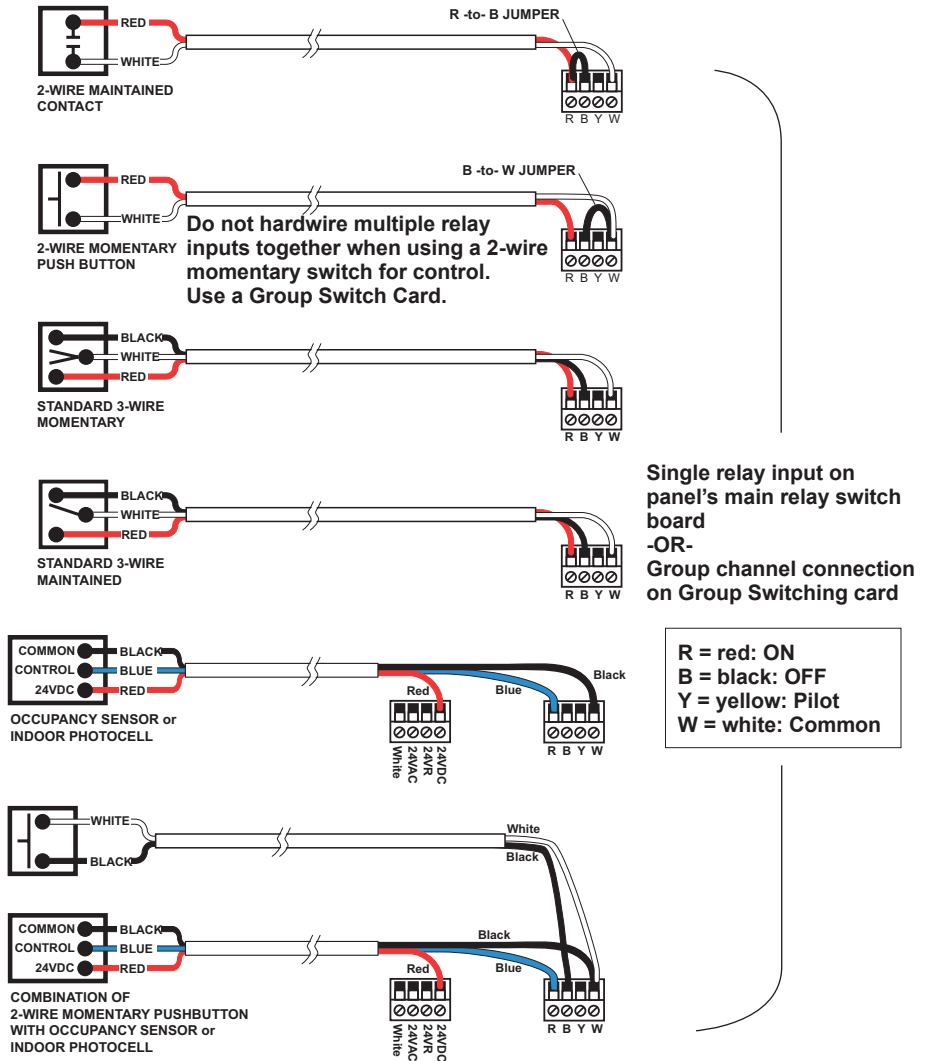

Figure 9: Low voltage switch and sensor wiring.

Install and Wire Exterior Photocell (Optional)

The LP8 has a specific terminal block for connection to a Wattstopper EM-24A2 exterior photocell. This photocell works in conjunction with the clock's automation scenarios to provide automatic exterior lighting control. See the Users Guide for programming information.

1. Mount the EM-24A2 on the building roof or exterior. Mount it so the light sensing window faces North.
2. Connect the two black wires and two red wires on the EM-24A2 to the PCELL terminal block at the top of the "C8" board on the low voltage side of the LP8 interior.

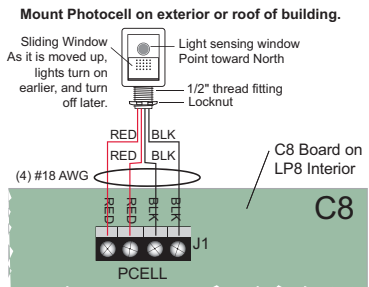

Figure 10: Installing the EM-24A2 Exterior Photocell with the LP8

Using Low Voltage Sensors with LP Panels

When connected as shown in the Low Voltage Wiring section, the sensor is powered by the panel's auxiliary power supply. It controls a relay when connected to a relay input. It controls a group of relays when connected to a GS input. Control behavior depends on the input to which the sensor is connected.

- **Sensor connected to a relay input:** sensor controls the relay based on the scheduled state of the relay
 - Scheduled OPEN: sensor turns relay **ON** but will not turn it **OFF**.
 - Scheduled CLOSED: sensor turns relay **ON** and **OFF**.
- **Sensor connected to a GS card input:** sensor turns the group of relays **ON** and **OFF** regardless of individual relay schedules.

To remove a sensor from the panel system after it has been commissioned, see **Troubleshooting item 7**.

GROUP SWITCHING (GS CARD) AND SMARTWIRE PROCEDURE (OPTIONAL)

The Group Switching card provides eight channels (A-H), which can be Smartwired to relays in the panel. GS channels are used to group relays for common control by switches or sensors. Do not confuse the GS channels with scheduling channels (discussed in the Users Guide). Group channels created using the GS card are used with switches or sensors connected to the card's inputs as shown in Fig. 3. These groups can be set to exactly or partially match the scheduling channels as required.

Smartwire Setup

1. On the Group Switching card, press and hold the Group push-button for several seconds. The red group LED and the LEDs for relays currently controlled by that input will begin to flash.
2. On each Relay Driver card, select the relays to be controlled.

If a relay was previously Smartwired to the group input selected, the LED flashes, otherwise the LED is off. Press the associated Relay Control Button to add/delete that relay to/from the group. The LED for each relay included in the group flashes.

3. On the Group Switching card, press the Group push-button again. All LEDs stop flashing and the input switch will now control the relays selected.

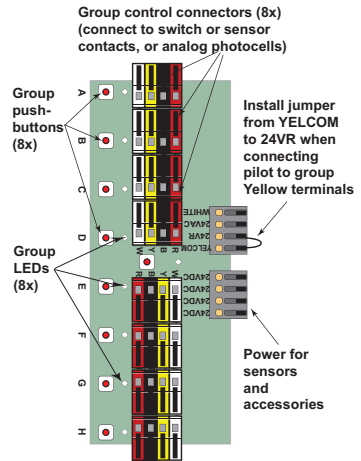
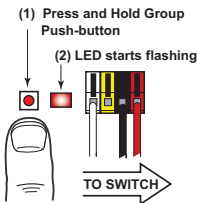
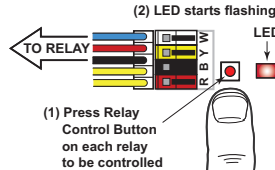

Figure 11: Group Switching

Step 1. GROUP SWITCHING CARD



Step 2. RELAY DRIVER CARD



Step 3. GROUP SWITCHING CARD

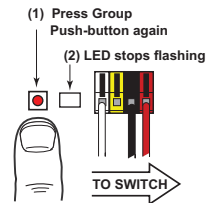

Figure 12: Smartwire Steps

Group LED Status Indicators

Red: All relays in group **ON**

Green: Relay group in mixed state (some **ON**, some **OFF**)

Off: All relays in group **OFF**

Test Smartwired Relay Group Channels

1. Press the Group Push-button **ON/OFF/ON** to toggle the group **ON/OFF/ON**. The input LED will track the last action.
2. With all relays in the group **ON**, turn **OFF** each relay in the group using the individual Relay Control Buttons on the Relay Driver card. When the last relay is turned **OFF**, the Group LED should also go **OFF**.

TROUBLESHOOTING

#	Problem	Test Steps	Next
1	The LV switch does not control the relay or group.	Is it terminated correctly in the panel? See pages 4 & 8.	No – Correct terminations
			Yes – Go to next step
		Is the 12VDC indicating LED on the C8 motherboard solid Green?	No – Cycle power to panel; recheck
			Yes – Go to next step
		Does the board mounted override pushbutton control the relay or group?	No – Call tech support
			Yes – Go to next step
		Disconnect input terminals. Does jumping the Red to White input terminals turn the relay on and does Black to White turn it off?	No – Call tech support
Yes - Verify the LV wiring is not shorted and that the switch is operating correctly			
If using a Group switch, have the relays been assigned to the particular group using the GS card?	No – Make the necessary assignments (refer to page 9)		
	Yes – Go to next step		
2	When I try to turn the relay off it goes off for a second then comes back on.	Is this relay scheduled using the “AS Manual ON/Auto OFF” or the “AS Automatic ON/OFF” scenarios.	No – Go to next Step
			Yes – The relay can only be overridden OFF during unoccupied periods
		Remove any LV switching that is landed at the relay input and attempt to turn relay ON using the board override buttons.	No change in status - Go to next step
			Relay functions normally - Verify the LV wiring is not shorted and that the switch is operating correctly
		Move LV relay connection to a different point on the RD board and attempt to override the relay on.	No change in status - relay needs to be replaced - call tech support
			Relay functions properly – circuit board needs to be replaced - call tech support
3	When I try to turn the relay on it comes on for a second then comes back off.	Remove any LV switching that is landed at the relay input and attempt to turn relay ON using the board override buttons.	No change in status - Go to next step
			Relay functions normally – Verify the LV wiring is not shorted and that the switch is operating correctly
		Move LV relay connection to a different point on the RD board and attempt to override the relay on.	No change in status - relay needs to be replaced - call tech support
			Relay functions properly – circuit board needs to be replaced - call tech support

#	Problem	Test Steps	Next
4	My EM24-A2 photocell does not turn the relay on or off.	Is the relay scheduled using the "Photocell ON/OFF" or "Photocell and Schedule ON/OFF" scenarios?	No – Make the necessary schedule changes and test again. Yes – Go to next step.
		Remove the photocell wires or connector and jumper from Red to Red. Do the relays turn on/off? Note: If using the "Photocell and Schedule ON/OFF" remember to adjust the clock time to be within your occupied times before doing the jumper.	No – Call tech Support Yes – Verify the LV wiring is not shorted and that the photocell is operating correctly on the roof.
5	The Astronomic schedule is turning on the relay too early/late.	Is the relay scheduled using the "Astronomic ON/OFF" or "Astronomic and Schedule ON/OFF" scenarios?	No – make the necessary changes and test again Yes – Go to next step
		Is the panel's location set up for the correct city/state?	No – make the necessary changes and test again Yes – Go to next step
		Is Daylight Savings set up correctly for the panel's location?	No – make the necessary changes and test again Yes – Call tech support
6	I go to enter my on and off times and I get the "You are attempting to enter a ON/ OPEN time that happens after the OFF/Close time. Please correct before moving on." Error message.	Are you entering ON/OFF times using the 24-hour format?	No – Using the 24-hour format make the necessary scheduling corrections Yes – Refer to the "Spanning Midnight With A Schedule" section of the User's Guide and make the necessary scheduling corrections
7	I need to remove a sensor from the system.	Once a sensor has been connected to a relay driver or group switch card low voltage input, the input will remain in the sensor mode even if the sensor is removed. To restore normal operation: 1. Remove the sensor wiring from the panel input. 2. Turn the associated relay or group off using the red override button corresponding to the input where the sensor had been connected. 3. Momentarily jumper the white and red terminals. 4. Does the relay/group turn on?	No – Call tech support Yes – Normal operation is restored. The input is configured for standard low voltage switches.

ORDERING INFORMATION - STANDARD CONFIGURATIONS

Catalog No.	Description of Lighting Control Panel
LP8S-4-115	Surface-mount cover, 4 relay; 115/277VAC
LP8F-4-115	Flush-mount cover, 4 relay; 115/277VAC
LP8S-8-115	Surface-mount cover, 8 relay; 115/277VAC
LP8S-8-347	Surface-mount cover, 8 relay; 115/347VAC
LP8S-8G-115	Surface-mount cover, 8 relay, Group switch card; 115/277VAC
LP8S-8G-347	Surface-mount cover, 8 relay, Group switch card; 115/347VAC
LP8F-8-115	Flush-mount cover, 8 relay; 115/277VAC
LP8F-8-347	Flush-mount cover, 8 relay; 115/347VAC
LP8F-8G-115	Flush-mount cover, 8 relay; 115/277VAC
LP8F-8G-347	Flush-mount cover, 8 relay, Group switch card; 115/347VAC
Optional System Equipment	
EM-24A2	Low voltage exterior photocell
AS-100*	Automatic control switch; 120/277VAC; 50/60Hz
LVS-1*	Standard momentary toggle switch
RS2-3x*	Two button low voltage momentary switch
L1S*	Single button low voltage architectural design toggle switch
LxS*	Multi-button low voltage architectural design toggle switch
DCC2*	Low voltage momentary switch, Miro Decorator style with LED

* Multiple options available, such as color, lighted/unlighted, keyed, number of buttons, etc. Consult **Legrand/Wattstopper Product Selection Guide** for details.

WARRANTY INFORMATION

Wattstopper warrants its products to be free of defects in materials and workmanship for a period of five (5) years. There are no obligations or liabilities on the part of Wattstopper for consequential damages arising out of, or in connection with, the use or performance of this product or other indirect damages with respect to loss of property, revenue or profit, or cost of removal, installation or reinstallation.

No. 24278 – 08/25 rev. 3

© Copyright 2025 Legrand All Rights Reserved.
 © Copyright 2025 Tous droits réservés Legrand.
 © Copyright 2025 Legrand Todos los derechos reservados.



800.879.8585

www.legrand.us/wattstopper