

## PA & PB Series Panel Protection Devices

Sentrex® PA and PB Series surge protection devices protect your sensitive electronic equipment from external or internal transient activity. Units can be customized with remote monitoring, noise filtration and flush mount options.

All PA and PB units are approved for indoor or outdoor use and feature all-mode protection. Units provide excellent protection when placed at branch panels or at specific pieces of equipment. They can also suppress external surges when mounted at the main service panel.

Also, the PA120T and PB120T are ideal for installation in residences to protect the entire home infrastructure, including expensive home appliances and home theater equipment.



**Meets UL1449  
Third Edition**

PA & PB Series provide surge protection at the main service panel, sub panel or at sensitive equipment.

### FEATURES & BENEFITS

- **Up to 160kA maximum surge current protection per phase.**
- **Easy installation.** Enclosure can be easily drilled or punched for conduit/cable access and positioned to the electrical panel at the discretion of the installer.
- **All-mode protection is standard on all units.**
- **NEMA 1, 2, 3, 3S, 4, 4X, 12, 13 rated, water-tight, fire-resistant plastic enclosure.**
- **34mm MOV circuitry.** Well exceeds the capacity of 20mm MOVs in parallel to manage surges over time.
- **Residential infrastructure protection.** PA120T & PB120T are ideal for providing protection for homes.
- **Type 2 Surge Protective Device (SPD).** Nominal Discharge Current (In) Rating of 5kA
- **Short circuit and thermal fusing.**
- **Low impedance circuitry.**
- **Short circuit current rating of 10kA.**
- **Visual indication of protection status.**
- **Ten-year product warranty.**
- **cETLus Listed to UL1449 Third Edition.**

### AVAILABLE OPTIONS

- **Remote diagnostic connection.** Using NO/NC dry contacts via on-board relay. Remote monitoring device sold separately.
- **EMI/RFI noise filter.** Noise attenuation -20dB minimum 100 kHz to 100 MHz.
- **Flush mount cover.** Sold separately.

## PA/PB Series Product Selection Guide

### PB Series – 160kA

CATALOG NUMBER	VOLTAGE (V ac)	PHASE	MCOV*	VOLTAGE PROTECTION LEVEL (VPR)							In RATING
				L-N	L-G	N-G	L-L	H-N	H-G	H-L	
PB-120T	120/240	1	150/300	800	1200	700	1500	–	–	–	5kA
PB-120Y	120/208	3Y	150/300	800	800	700	1500	–	–	–	5kA
PB-240DCT	120/240	3H	150/300	800	1200	800	1500	1200	1500	1800	5kA
PB-277Y	277/480	3Y	320/640	1200	2000	1200	2000	–	–	–	5kA

\* Maximum Continuous Operating Voltage

L – (Line), N – (Neutral), G – (Ground), H – (High Leg), +D – (Delta), Y – (Wye), H – (High Leg Delta)

### PA Series – 80kA

CATALOG NUMBER	VOLTAGE (V ac)	PHASE	MCOV*	VOLTAGE PROTECTION LEVEL (VPR)							In RATING
				L-N	L-G	N-G	L-L	H-N	H-G	H-L	
PA-120T	120/240	1	150/300	800	1200	700	1500	–	–	–	5kA
PA-120Y	120/208	3Y	150/300	800	800	700	1500	–	–	–	5kA
PA-240DCT	120/240	3H	150/300	800	1200	800	1500	1200	1500	1800	5kA
PA-277Y	277/480	3Y	320/640	1200	2000	1200	2000	–	–	–	5kA

\* Maximum Continuous Operating Voltage

L – (Line), N – (Neutral), G – (Ground), H – (High Leg), +D – (Delta), Y – (Wye), H – (High Leg Delta)

**Options:** (select options by adding hyphen and suffix to part number)

**A – Remote Monitoring Capability**

Adds NO/NC dry contacts to PA/PB unit via on-board relay. Dry contacts will allow for connection of remote monitoring unit. Remote monitoring unit itself sold separately under part #ZHRMU. See page 3 for ZHRMU specifications.

**B – Noise Filter**

Provides noise attenuation of -20dB minimum 100kHz to 100 MHz.

**How to Configure A Part Number:**

- 1 Select CATALOG NUMBER.
- 2 Select OPTIONS if desired.
- 3 Part Number is CATALOG NUMBER, followed by HYPHEN, followed by OPTIONS in alphabetical order.

SAMPLE

160kA for 120/208V  
with Noise Filter

SAMPLE

80kA for 277/480V  
with Remote Contacts  
with Noise Filter

SAMPLE

80kA for 120/240V  
No Options Selected

**Part#: PB120Y-B**

**Part#: PA277Y-AB**

**Part#: PA120T**

## PA/PB Series Accessories

Product	Description/Specifications
<p><b>Remote Monitoring Unit</b></p> 	<p>Offers clear audio/visual indication of the status of the surge suppressor unit. The RMU can be installed adjacent to the suppressor or as a remote installation. Can also be used as a standalone diagnostic device using NO/NC dry contacts. Powered by 2 AA alkaline batteries (included) which will power the unit for approximately 2 years. Unit connects with with Cat5 cable (not included).</p> <p><b>SPECIFICATIONS</b></p> <p><b>Dimensions:</b> 5.4" x 2.6" x 1.3" [13.7mm x 6.6mm x 3.3mm]</p> <p><b>Weight:</b> Approx. 0.35lb [0.16kg] including batteries.</p> <p><b>Protection Indication:</b> Bright green LED: Illuminated, flashing</p> <p><b>Fault Indication:</b> Audible alarm. Bright red LED: Illuminated</p> <p><b>Test Functions:</b> Switch tests audible alarm (checks monitoring circuitry)</p> <p><b>Silent Function:</b> Switch silences audible alarm</p> <p><b>Connections:</b> Accepts wires up to #14 AWG (Cat5 recommended)</p>
<p><b>PABFMC</b></p>	<p><b>Flush Mount Cover</b> – For installing PA/PB units on sheetrock or firewall construction. Cover hides the hole cut and gives the unit a finished look. Brushed metal cover can be painted to match any decor.</p> <p><b>SPECIFICATIONS</b></p> <p><b>Dimensions:</b> 9" x 7" [229mm x 178mm]</p>

\* NOTE: ZHRMU can only be used on PA/PB Units with remote contacts (Option A). ZHRMU is also compatible with all ZoneMaster Units (see ED1165 for details).



## PA/PB Series Specifications

### MECHANICAL SPECIFICATIONS:

<b>Enclosure:</b>	Durable, lightweight, corrosion-resistant high impact plastic. Approved for outdoor or indoor use. NEMA 1, 2, 3, 4, 4X, 12, and 13 rated.
<b>Dimensions:</b>	6 5/16" x 4 3/4" x 3 9/16" (160mm x 120mm x 90mm).
<b>Weight:</b>	PB Series: 1.8 lbs. (0.8 kg), PA Series: 1.4 lbs. (0.6 kg).
<b>Operating Environment:</b>	-40°C to 85°C, 95% relative humidity (non-condensing).
<b>Construction:</b>	Low impedance circuitry. Single board system to minimize transient impedance and suppression voltage.
<b>Terminal Lugs:</b>	#10 AWG maximum and recommended wire size.
<b>Mounting:</b>	Built-in mounting holes, 11/64" [4.4mm] diameter. Enclosure can be easily drilled or punched for conduit/cable access.

### ELECTRICAL SPECIFICATIONS:

<b>Maximum Surge Current Capacity Per Phase:</b>	<b>PB Series: 160,000A</b> <b>PA Series: 80,000A</b>
<b>Maximum Surge Current Capacity Per Mode:</b>	<b>PB Series:</b> L-G 80,000A (8/20µs), L-N 80,000A (8/20µs), L-L 160,000A (8/20µs), N-G 80,000A (8/20µs) <b>PA Series:</b> L-G 40,000A (8/20µs), L-N 40,000A (8/20µs), L-L 80,000A (8/20µs), N-G 40,000A (8/20µs)
<b>Duty Cycle Performance (Surge Life):</b>	PB Series: 20 pulses at 10,000A PA Series: 10 pulses at 10,000A
<b>Maximum Continuous Operating Voltage:</b>	20% above nominal
<b>Short Circuit Current Rating:</b>	10,000A
<b>Optional Remote Indication Contacts:</b>	NO/NC dry contacts via on-board relay, 125VAC, 2A rated
<b>Optional EMI/RFI Noise Attenuation:</b>	-20dB Minimum 100 kHz to 100 MHz
<b>Diagnostics:</b>	Green LED per phase indicates protection present on each phase
<b>Protection Technology:</b>	34mm MOV based, backed by thermal and short circuit fusing
<b>Installation:</b>	Unit should be connected through a dedicated 30 amp circuit breaker with the appropriate poles (customer supplied).

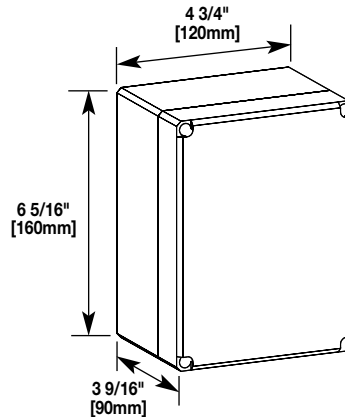

Questions? Call Technical Support at 1-800-SENTREX



#### Electrical Wiring Systems

60 Woodlawn Street  
West Hartford, CT 06110  
Phone: 1.877.BY.LEGRAND (295-3472)  
www.legrand.us

570 Applewood Crescent  
Vaughan, Ontario L4K 4B4  
Phone: 905.738.9195  
www.legrand.ca

