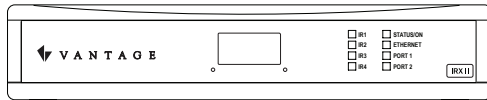

**IRX II**

Country of Origin: Made in China

**OVERVIEW**

The IRX II is Vantage's latest IR Emitter station using Ethernet or Station Bus to communicate. It plays another important role in the Vantage Audio/Video solutions family of products. A small footprint allows easy installation anywhere; this product has been designed to fit within an AV rack with an optional rack-mount kit or as a standalone beside or behind a TV/entertainment center for local control of a smaller system.

An optional wall mount unit is also available. The IRX II is scalable with four IR out channels (IR channels may be piggybacked allowing up to eight IR controlled devices), two RS-232 ports with flow control, internal IR receiver, external IR receiver and external IR pass through. It also has two Low Voltage Relays for control of theater blinds, screens or other equipment often used in a home theater and four contact inputs for external sensors, rounding out the IRX II's connection ports. In most IRX II applications, dry contact inputs are used as sensors for LED indicators or current sensors etc., allowing direct hardware tracking of most equipment's ON/OFF state. IRX II ships with a universal power supply with an assortment of international wall plugs.

**FEATURES AND OPERATION OVERVIEW**

- Four IR outs (with option for 4 more piggybacked)
- Two high speed RS32 ports (on LAN connection that can switch TX/RX in software; no more null modems)
- Two low-voltage relays
- Built-in IR receiver
- Two external IR inputs (1 pass through)
- Four contact inputs for sensors
- Network based (or Vantage Station Bus)
- Fully compatible with Design Center software

**SPECIFICATIONS**

Description	Specification
Dimensions	1.7" x 8.5" 6.125" (43mm x 216mm x 156mm)
Weight (without power supply)	1.1 lbs (499g)
Power Requirement	Input: 120-240VAC, 60/50Hz Output: 12VDC 1.5A
Dry Contacts / Sensor Probes	4 Channels
External 12V Power Terminals	500mA, combined total
Four (4) IR Emitter Outputs Mono 3.5mm Mini Plug	Controls: 4 IR Devices Piggybacked: 8 IR Devices
Max. Wire Length For Emitter Cables	50 feet, recommended 16-20 AWG
Internal IR Receiver	1
Input for Vantage or Compatible IR Receivers	1
Input for Xantech Compatible IR Receivers	1
Two (2) Low-voltage Relays	48 VAC or 30VDC. 1 amp max. each

## SPECIFICATIONS *(continued)*

Description	Specification
RS-232 Ports	2
Station Bus Lightning / Surge Protection	Low-voltage ITU-T K.20
Ethernet Bus Port (VEB)	RJ45 - Auto crossover Detection
IP Address	AUTO-RANGE - Do not change
Station Bus Ports (VSB)	1
Status LEDs	10
Station Bus Specification	2C, 16AWG / 1.31mm <sup>2</sup> , twisted, nonshielded, <30pF per foot. Separate a minimum of 12" / 30.5cm from other parallel communication and/or high-voltage runs
Station Equivalent InFusion	0.36W on IC-24 / 0.54W on IC-36
Station Bus Voltage	24V / 36V Station Bus
Ambient Operating Temperature	32-95°F (0-35°C)
Ambient Operating Humidity	5-95% non-condensing
Cooling	Convection
FreeRTOS	Real-time scheduling provided by FreeRTOS ( <a href="http://www.freertos.org">www.freertos.org</a> )
Certifications	UKCA, CE, (EN 55032, EN 55035, EN 61000-3-2, EN 61000-3-3)

## STATUS LED INDICATORS

**NOTE:** Green + Red, Display Amber

FRONT PANEL	GREEN	RED
Status / Power	Diagnostic	Power
Ethernet	Activity	Link OK
Port 1 and 2 (Com 1 and 2)	TX	RX
IR Channels: IR1 - IR4	IR Activity	Not Used
REAR PANEL	GREEN	AMBER
Ethernet Jack	Activity	Link OK

## INSTALLATION

### POWER SUPPLY

The IRX II should only be operated with the supplied AC/DC adapter. Using another power supply may result in product malfunction and could void the warranty. Please see: *12V Power Connections*.

### ETHERNET OR STATION BUS

The IRX II can communicate with the InFusion System using the Vantage Ethernet Bus, allowing large amounts of information to be moved over Ethernet. Many products today move large amounts of metadata, often bi-directional, requiring a high speed connection. For this reason, the Ethernet connection is recommended when using one or both RS-232 ports for controlling additional equipment that produce large amounts of bi-directional information.\*

Vantage's Multi-Zone Amp or other third party equipment controlled via RS-232 can be directly connected to the IRX II. Utilizing the RS-232 ports on the back of the IRX II eliminates the need to run an RS-232 connection from the equipment back to an InFusion Controller. Because the IRX II communicates over the local network, these RS-232 connections remove the distance restrictions normally associated with RS-232.

### NOTE TO INSTALLER AND CLIENT:

Should the IRX II require removal from the system for servicing, control of the Multi-Zone Amp or other RS-232 equipment will be lost for the duration.

### NOTE:

IRX II may be connected using the Station Bus through two screw terminals on the back of the IRX II instead of the Ethernet connection. The Station Bus connection works well when using the IRX II to transmit/receive IR codes, drycontacts and simple RS-232 codes. A Station Bus Receptacle is available that is used to make a finished connection from the wall to the IRX II (part # ROS-1). Never connect both Ethernet and Station Bus communication ports at the same time.

### 9-PIN, RS-232 PORTS

Serial ports on the IRX II are fully programmable from Design Center software. Each port includes the following information, setup and adjustable communication protocol settings:

- Serial Port Name
- VID
- Data (object notified when data is received)
- Write (object notified when it is OK to write again)
- Connect (object notified when connection established)
- Disconnect (object notified when connection lost)
- Baud Rate
- Parity
- Data Bits
- Stop Bits
- Flow Control
- Process Host Commands (Allows/disallows Host Commands processing)
- Crossover (Switches TX, RX and RTS, CTS Lines)

### 12V POWER CONNECTIONS

While the IR/IN and IR/PASS terminals have their own 12V screw terminals, the first two screws on the bottom terminal are also for power. Multiple connections may be made to the bottom terminal's power source as when using more than one Vantage, IR-ISO-II, Powered Opto-Isolated Emitter Cable. All of the 12V terminals are in parallel as well as all of the ground connections. The 12V power connections, on the back of the IRX II, are rated (collectively) at a maximum of 500mA combined. This is sufficient power to control most connections made to the IRX II.

The 12V power supply is fused using a PTC, self resetting fuse. If too much power is drawn or is shorted, the fuse will trip, protecting the power supply in the IRX II. When the excessive load or short is removed the fuse will automatically reconnect.

---

## EMITTERS

---

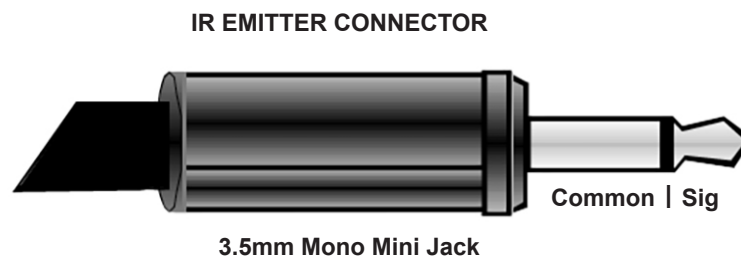

Infrared emitters are plugged into the 3.5mm mono, mini plug jacks on the back of the IRX II\*. The other end of the infrared emitter is connected to the infrared receiver window on the Audio/Video equipment. Flasher and direct connect, opto-isolated type emitters are available from Vantage; flasher type, part # Q-EMITTER, and isolated direct wire, part # IR-ISO-II. Direct wire emitters may also be used on equipment with a mono mini plug *input* for IR control. If a ground-loop is suspected when using direct wire emitter cables, Vantage recommends using the IR-ISO-II connector. Please see the Vantage installation instruction sheet for the Powered Opto-Isolated Emitter Cable, IR-ISO-II.

### \* CONNECTIONS

Please carefully study the Emitter Connection examples below for proper operation of IR equipment. The following three examples should cover most emitter installation scenarios. In each of the three examples it is very important to correctly set the *Emitter Connection* parameter in Design Center to *Current* (Light) or *Voltage* (Direct Connect).

## EMITTER CONNECTION SETTINGS IN DESIGN CENTER

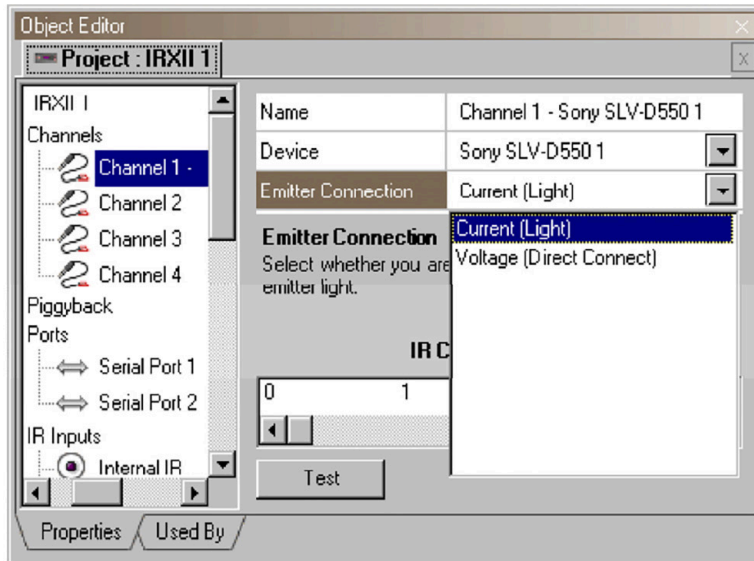

1. Flasher type emitters require the *Emitter Connection* parameter in Design Center be set to *Current (Light)*. Flasher type emitters come in two types visible light and non-flashing – no visible light.

### IRX II SET TO: CURRENT (LIGHT)

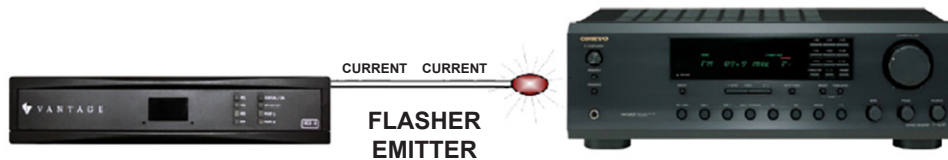

2. Direct wire emitters require the *Emitter Connection* parameter in Design Center be set to *Voltage (Direct Connect)*. Direct wire emitters connect directly from the IRX II to the controlled equipment via 3.5mm Mono Mini Jacks at both ends.

### IRX II SET TO: VOLTAGE (DIRECT CONNECT)

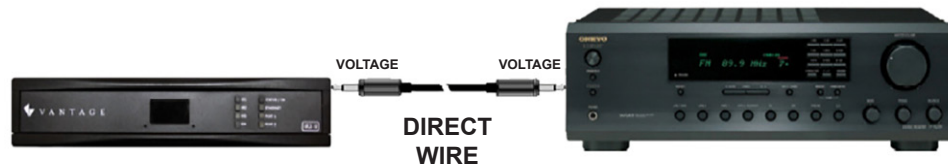

3. Vantage's IR-ISO-II, Opto-Isolated, direct wire emitters require the *Emitter Connection* parameter in Design Center be set to *Current (Light)*. The Current is converted to Voltage automatically when using Vantage's IR-ISO-II. Direct wire emitters connect directly from the IRX II to the controlled equipment via 3.5mm Mono Mini Jacks at both ends.

### IRX II SET TO: CURRENT (LIGHT)

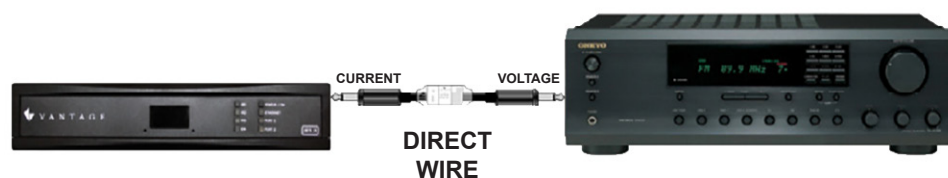

VANTAGE OPTO-ISOLATED IR-ISO-II EMITTER

---

## INTERNAL INFRARED RECEIVER

---

The IRX II has an internal IR receiver in the middle of the front panel. This receiver is activated or deactivated in Design Center. When activated, it may be assigned to any Vantage IR Zone. Vantage IR remotes, like the Vantage Small Remote, model, V-SIRC, may be used to control the vantage system through this receiver.

---

## REMOTE INFRARED RECEIVER

---

The IRX II has two screw terminal sets for remote (external) infrared receivers.

### IR-IN PORT:

- Designed to work with a Vantage REMOTEIR or Q-REMOTEIR or 3rd party external receivers that *strip* the carrier frequency.

### IR-PASS PORT:

- Supports receivers that *do not strip* the carrier frequency (Xantech types).
- With the Pass Thru box, *checked*, the signal is simply routed to the designated emitter, Channel 1-4.
- The signals *data timing* and *carrier frequency* are not modified or recognized by the Vantage system. Voltage\*, emitter *Power*, and the pass thru *Channel* are selectable in Design Center for receivers connected to this port.
- With the Pass Thru box, *not checked*, this port supports Vantage codes with a Xantech, type receiver connected.
- The Voltage box should be checked in Design Center, if the selected channel is using Voltage (Direct Connect), as in example number 2 under *Emitter Connections*.

---

## CONTACT INPUTS

---

The bottom screw terminal's last eight screws are used for connecting, up to four, contact closure inputs to the IRX II. These inputs may be used for tracking the on/off state of equipment controlled by the IRX II or they may also be programmed like any other contact input. Contact inputs should be either a relay closure or a solid state switch. If connections to any of these inputs use an external power supply with a separate ground connection, it may be necessary to use an isolated ground connection between the sensor and the IRX II. Test before adding a ground isolation device.

### GROUND LOOP POTENTIAL

The IRX II's power supply and Station Bus ground connections are already isolated. Ethernet is also isolated from ground loops inherently. However, if multiple external RS-232 and/or dry-contacts with external power sources are connected, there is still a potential for ground loops. (Do not interpret this as stating that ground loops will automatically happen with multiple externally powered devices.)

**IMPORTANT:** When connecting an RS-232 communication device or dry contact, and the device is not using the same power source or is far away, a ground loop or data noise condition may occur. If this condition is suspected, Vantage recommends a third party Opto (optical) Isolation Module. Opto Isolation provides a communications link and is an important consideration if a system uses different power sources, has noisy signals or must operate at different ground potentials.

---

## STATUS / ON LED BLINK PATTERNS

---

Working normally, the Status LED blinks once per second. Other patterns are 2, 3, 4 or 5 blinks followed by a short pause.

### BLINK PATTERNS BETWEEN RED AND AMBER:

BLINK CYCLE	STATION BUS	ETHERNET
1	Configured / Programmed	Configured / Programmed
2	Communicating	TCP Connection
3	No Station Bus Connection (See Note 1)	No TCP Connection
4	Station Problem	Station Problem
5	Configuration Mode	Configuration Mode

**NOTE 1:** Station is not communicating with the Main Controller. Verify Station Bus wiring is correct.

---

## INSTALLATION OPTIONS

---

The IRX II may also be installed with the aid of two optional mounting products. See respective installation sheets on the web.

**RACK MOUNT:** Designed to mount the IRX II in a rack system using 1U of rack space. This optional rack mount device is designed to hold one or two IRX II units while still only using the same 1U vertical space.  
(PART # IRX II-RACK)

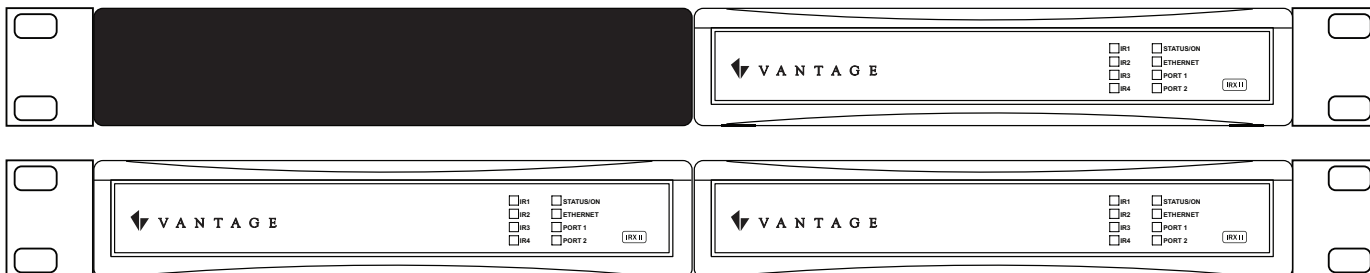

[RACK MOUNT IRX II-RACK Install Sheet](#)

**WALL MOUNT:** Designed to mount the IRX II to cabinets, walls, inside racks, etc. This unit is designed to hold one IRX II and allows the front and back side of the IRX II to be visible. The front and back are free of obstructions for easy access to wire connections and LED monitoring even when mounted. (PART # IRX II-WALL)



[WALL MOUNT IRX II-WALL Install Sheet](#)

---

## CONNECTORS BACK PANEL

---

The close-up drawing below shows the two 10-screw connectors on the back of the IRX II with the connectors removed. Use this drawing to become familiar with each terminal screw's specific purpose and for help with wiring during installation.

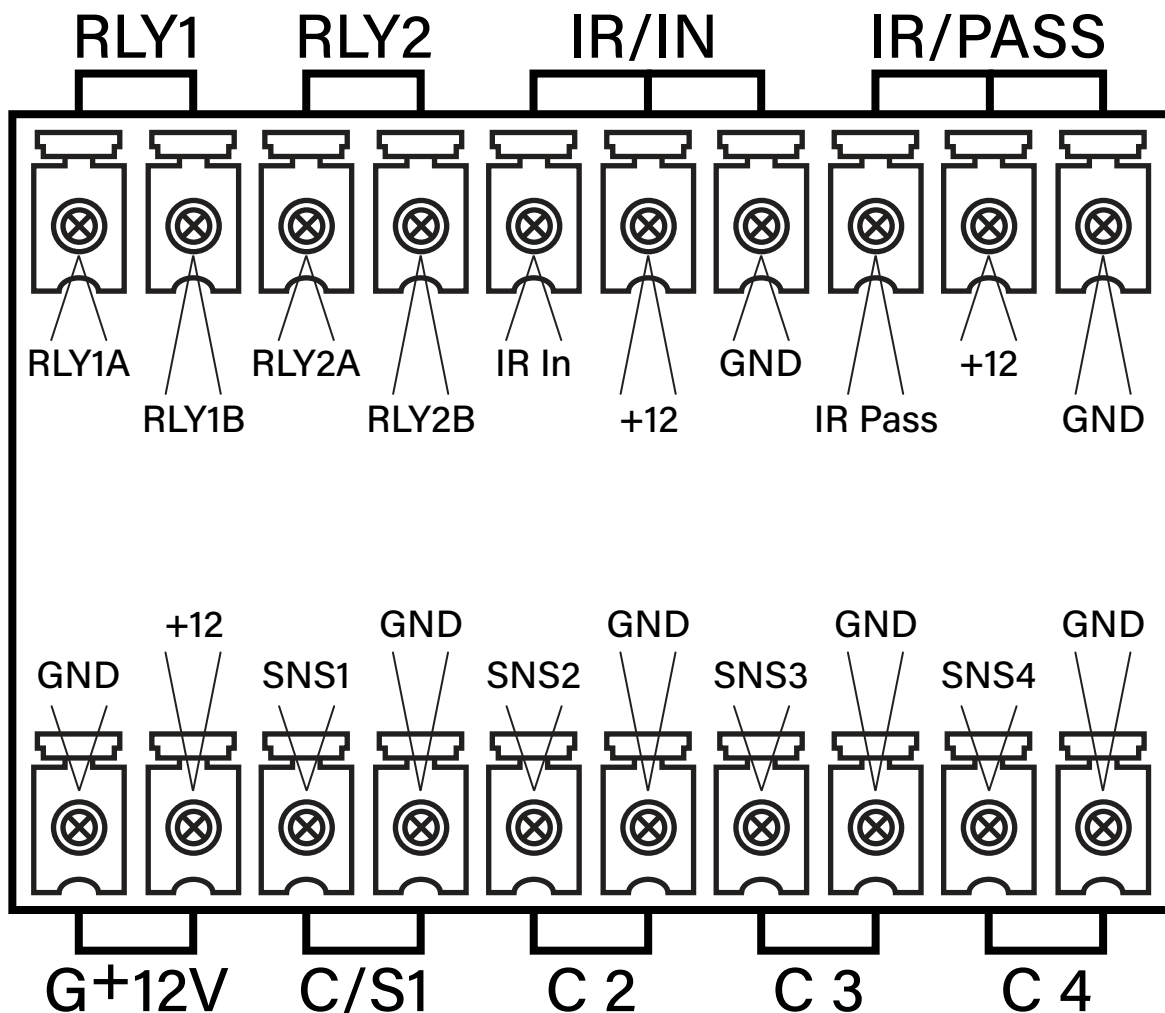

---

## CONFIGURATION

---

When the IRX II is first powered the STATUS / ON LED, on the front, will glow red. When connected to the Station Bus or Ethernet, the STATUS / ON LED will glow red and blink amber twice followed by a short pause, indicating the IRX II is connected correctly but is not configured. This two blink pattern indicates the IRX II station needs to be configured and programmed to associate the physical station with the station in software.

In Design Center, click the *Configure Stations* button on the toolbar. The STATUS / ON LED will blink amber five times followed by a short pause and repeat. With the IRX II highlighted in Design Center, press the configure station button on the front of the IRX II. Use a paper clip or similar small tool to insert into the right hole to press the button. The station may also be configured by typing the serial number in the project file. Using this method the station will automatically be configured when the system is programmed.

**NOTE:** Switching from Ethernet bus to Station bus, or Station Bus to Ethernet bus requires these steps:

- Unconfigure the IRX II in Design Center
- Update the system from Design Center
- Re-configure on the new bus.
- Update the system again from Design Center

---

## HELPFUL HINTS

---

### **POWER TRACKING**

Some Audio/Video equipment has only one infrared code to turn power on and off it is impossible to know if the power code is going to turn the equipment on or off without knowing whether the equipment is currently on or off. The Vantage Infrared code sets have a code to turn power on and a code to turn power off. If the infrared code set has both a Power On and a Power Off code (discrete codes) power tracking becomes much less important. If a code set only has one Power code this code will be used for Powering On or Powering Off the equipment. In this case, some form of power tracking becomes essential. IR Drivers created in Driver Designer have a "Discrete" parameter that is set to False or True. Design Center in conjunction with the IR Driver uses internal logic based on the Driver information to keep the code being sent in sync with the actual state of the hardware. If the equipment does not have discrete codes, using the contacts with sensors is preferable so the InFusion system always knows the state of the equipment.

### **VOLUME CONTROL**

The volume up and volume down infrared codes work different than the other codes. Most other codes are sent a fixed number of times when a button is pressed. The volume codes are sent until the button is released.

### **POWER LEVEL**

Some equipment can be sensitive to the strength of the IR signal since the infrared transmitter is right next to the infrared window. The amount of transmitted power can be adjusted and tested from Design Center by selecting the Driver.

### **REPEAT VALUE**

The Repeat Value is the number of times a code is sent. This is value is in the IR Driver and is set using the Driver Designer Software.

### **BLOCKING INFRARED**

When using an infrared remote that is pointed in the same general direction as the equipment controlled by an IRX II, it is possible for the transmission from the remote to interfere with the IRX II transmissions. It is very important in this situation that the infrared window on the equipment be blocked completely from receiving any other infrared transmission.

### **IR LEARNER II**

To learn codes from an infrared remote not contained in the Vantage Infrared Code database, use the Vantage IR Learner or IR Learner II with Driver Designer. The IR Learner connects to a PC allowing new IR code sets to be learned.

**NOTE:** The IR-LEARNER (old model) requires a 9-pin serial port or adaptor to the computer. The IR-LEARNER II connects to any USB port on the computer.

MULTI-VIEW LINE DRAWINGS IRX II

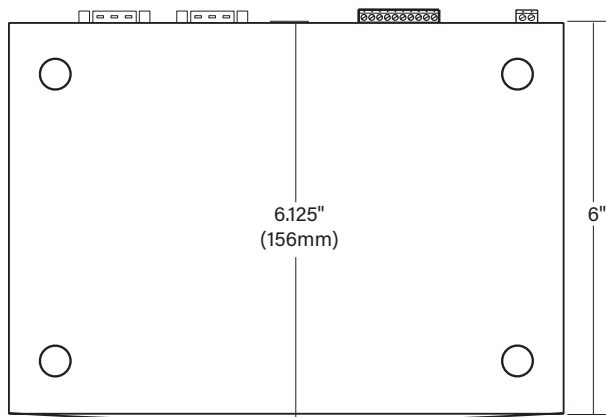

BOTTOM VIEW

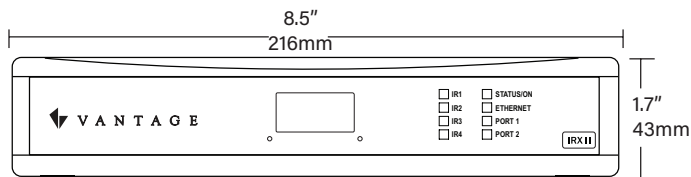

FRONT VIEW

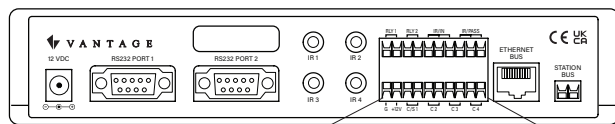

BACK VIEW

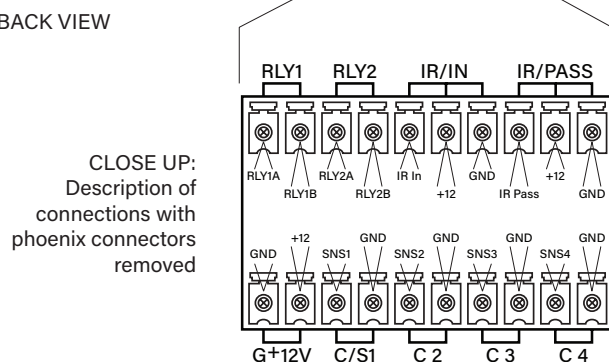

CLOSE UP:  
Description of  
connections with  
phoenix connectors  
removed

WARRANTY INFORMATION

Vantage warrants its products to be free of defects in materials and workmanship for a period of five (5) years. There are no obligations or liabilities on the part of Vantage for consequential damages arising out of, or in connection with, the use or performance of this product or other indirect damages with respect to loss of property, revenue or profit, or cost of removal, installation or reinstallation.

INFORMATIONS RELATIVES À LA GARANTIE

Vantage garantit que ses produits sont exempts de défauts de matériaux et de fabrication pour une période de cinq (5) ans. Vantage ne peut être tenu responsable de tout dommage consécutif causé par ou lié à l'utilisation ou à la performance de ce produit ou tout autre dommage indirect lié à la perte de propriété, de revenus, ou de profits, ou aux coûts d'enlèvement, d'installation ou de réinstallation.

INFORMACIÓN DE LA GARANTÍA

Vantage garantiza que sus productos están libres de defectos en materiales y mano de obra por un período de cinco (5) años. No existen obligaciones ni responsabilidades por parte de Vantage por daños consecuentes que se deriven o estén relacionados con el uso o el rendimiento de este producto u otros daños indirectos con respecto a la pérdida de propiedad, renta o ganancias, o al costo de extracción, instalación o reinstalación.