

EMERGENCY LIGHTING CONTROL UNIT

ELCU-200

Guarantees emergency lighting remains ON or is turned on when power to the control device is lost

“Watchdog” feature allows emergency loads to be controlled in tandem with normal power loads

Integrated push-to-test button

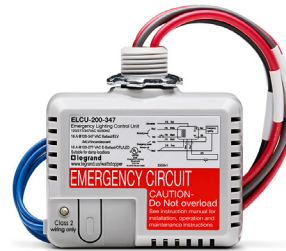
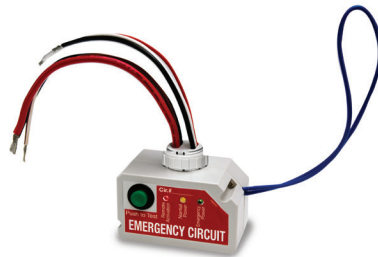

Interfaces with fire alarm panel or security system

UL listed for use in emergency circuits



DESCRIPTION

Wattstopper's ELCU-200 Emergency Lighting Control Unit is a self-contained device that allows any standard lighting control device to control emergency lighting in conjunction with normal lighting in any area within a building.

OPERATION

The ELCU-200 monitors a single circuit that provides normal lighting to an area. As long as normal power is present, the ELCU-200 permits lighting control devices (e.g., occupancy sensors, panels, dimmers, or wall switches) to control the emergency lighting fixtures as well as the general lighting. If power is lost for any reason, including the tripping of a single branch circuit breaker, the ELCU-200 will force on the emergency lighting fixtures for that area. The ELCU-200 can be wired either as a control device, so that emergency lighting follows the control of normal lighting, or as a bypass device to shunt emergency power around a control device (e.g., a dimmer) when normal power fails.

Power for the ELCU-200 is drawn from normal power connections. The Emergency feed goes through a normally closed relay and there is no current drawn from that circuit.

FEATURES

- Eliminates energy waste caused by emergency lighting that is always on
- Integral push-to-test button activates emergency mode for a true test condition
- Connects to EMTS-100 Remote Test Switch or other input to activate emergency on from a remote location
- Operates as a control device or as a shunt
- Senses local single circuit power failure
- Zero cross switching technology for reliability and increased product life
- Compatible with Wattstopper occupancy sensors, daylighting controls, lighting control panels, and dimmers
- LED indication for emergency and normal power
- Half-second delayed on positively identifies emergency fixtures for required maintenance
- Provides absolute fail-to-on emergency lighting
- UL924 listed, meets NEC, OSHA and NFPA safety codes; CSA C.22.2 No. 141-15, Unit Equipment for Emergency Lighting; UL2043 plenum rated
- BAA/BABA-compliant model available

PROJECT

LOCATION/
TYPE

SPECIFICATIONS

- ELCU-200 & ELCU-200-U: 120/277VAC; 50/60Hz
ELCU-200-347: 120-347VAC; 50/60Hz; single phase
- Power Consumption: 230mW @ 120V, 360mW @ 277V
- Maximum load (120/277V):
 - Ballast/LED/E-Ballast/CFL 20A @120/277VAC
 - Incandescent 10A @120/277VAC
 - Motor 1/4HP @120VAC
- Maximum Load
 - Ballast/ELV/MLV/Incandescent 16A @120-347VAC
 - LED/E-Ballast/CFL 16A @120-277VAC
 - Motor 1/4HP @120-347VAC
 - Plug Load 15A @120VAC
- Remote activation: supplies 24 VDC source for dry contact closure
- Integral control: push-to-test button on unit
- Housing: fire rated V-0, 176° F (80°C)
- Operating temperature range
 - ELCU-200: 32° to 122°F (0° to 50°C)
 - ELCU-200-347: -4° to 131°F (-20° to 55°C)
- Relative humidity range: 5 to 95%, noncondensing
- Dimensions: 1.7" x 2.97" x 1.64"
(43.2mm x 75.4mm x 41.7mm) H x W x D with a 1/2" (12.7mm) threaded nipple
- UL 2043 Plenum Rated; UL 924, Emergency Lighting and Power Equipment; CSA C.22.2 No. 141-15, Unit Equipment for Emergency Lighting
- Five year warranty

INSTALLATION AND SYSTEM WIRING

ELCU Wired As a Control Device

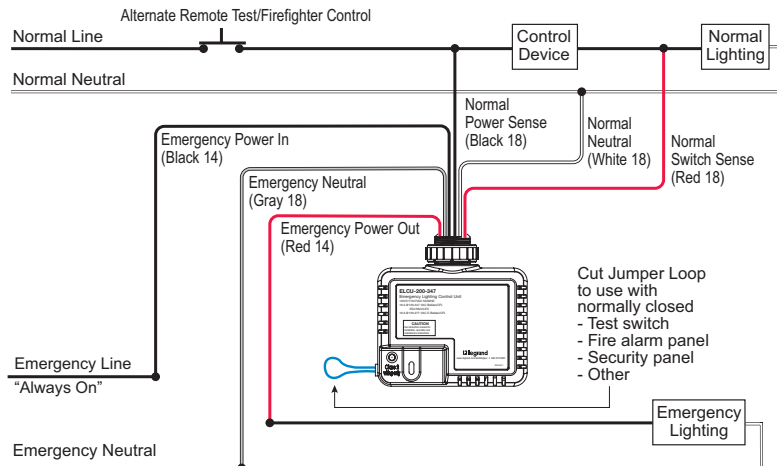

When wired as a control device, the ELCU-200 receives a switching signal from the output of the control device (relay, switch, power pack, etc.)

ELCU Wired As a Shunt or Bypass Device

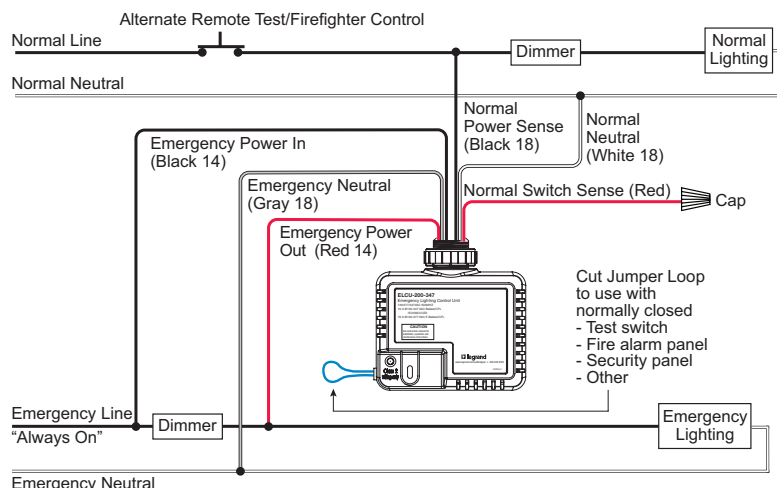

When wired as a shunt, the switching line is not used.

NOTE: Phase Dimmers used on the Emergency Circuit should be approved for this application by the manufacturer. Otherwise, use the AD-EPC-D-F-ATS Emergency Lighting Transfer Switch for this application.

1. You can connect as many NC contacts (including EMTS-100) in series on the jumper loop wire as you want to a single ELCU. You cannot connect the NC devices in any other manner.

2. At no time can more than 5 ELCU devices can be controlled together by commoning their Test Loop wires to a Normally Closed Test Switch (EMTS-100) and/or other NC contact closure.

3. If connecting ELCUs together via their test loop wires, you must maintain the polarity of their wires.

When testing the ELCU with 0-10V controls, which must be complimentary listed to "emergency lighting equipment UL924", the 0-10V control must be removed, either by depowering the control device or disconnecting the 0-10V conductors. Failure to remove the 0-10V control may not allow the load to turn on to full brightness. The ELCU relies on complimentary equipment to disconnect the 0-10V control upon normal power loss.

ORDERING INFORMATION

Catalog #	Description	Voltage
<input type="checkbox"/> ELCU-200	Emergency Lighting Control Unit	120/277VAC; 50/60Hz
<input type="checkbox"/> ELCU-200-U	Emergency Lighting Control Unit, BAA/BABA compliant*	120/277VAC; 50/60Hz
<input type="checkbox"/> ELCU-200-347	Emergency Lighting Control Unit	120-347VAC; 50/60Hz
<input type="checkbox"/> EMTS-100	Remote Test Switch on single gang plate	24VDC, normally closed contact

*Product is compliant with the Buy American Act and Build America, Buy America Act