

HIGH FREQUENCY OCCUPANCY SENSOR

FM-105

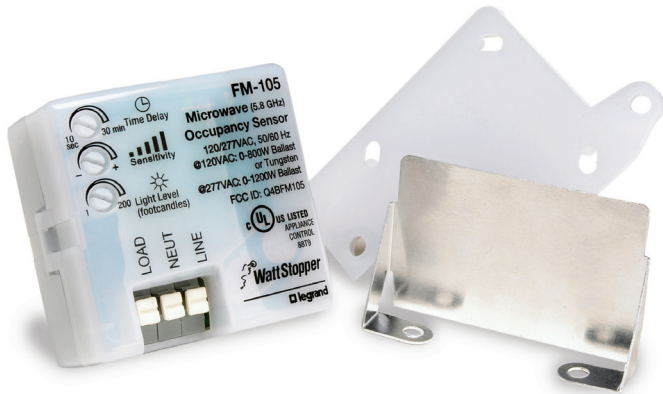

PRODUCT OVERVIEW

The FM-105 High Frequency Occupancy Sensor is a line voltage sensor that turns lighting on and off based on occupancy, and can hold lights off when sufficient daylight is available.

It detects motion via high frequency electromagnetic waves and the Doppler principle. Because it can detect motion

through many dense materials other than metal, the FM-105 can be installed behind fixture lenses and hidden from view.

The FM-105 can be used in a water-tight non-metallic box or water-tight luminaire for wet location applications.

Trim pots allow the user to adjust time delay, sensitivity/range, and the light level setpoint.

Time Delay sets the time interval lights remain ON after motion ceases to be detected. A time delay of 30 minutes, the maximum allowable by ASHRAE 90.1, is recommended for most applications.

Detection sensitivity can be adjusted up to 20 feet.

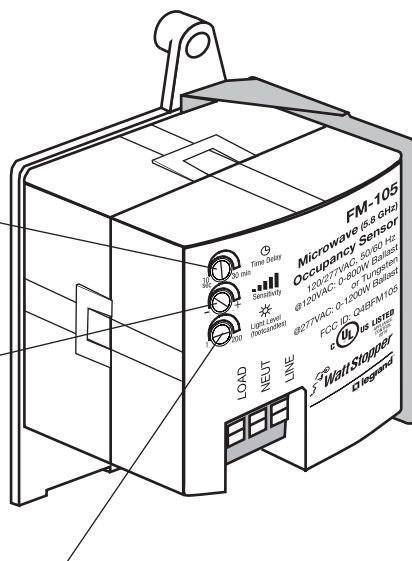

Integrated hold-off daylighting control prevents the load from turning on if the ambient light level is brighter than the light level setpoint.

MODELS

FM-105

SPECIFICATIONS & FEATURES

120/277VAC, 50/60 Hz
@ 120VAC, 0-800 W ballast or tungsten
@ 277VAC, 0-1200 W ballast

Power output: 1 mW

Power consumption: 0.5W @ 120VAC

Operating frequency: 5.8 GHz

Integrated photosensor for Hold-OFF daylighting control (2 to 200 fc)

Adjustable sensitivity range up to 20 feet (6.1m)

Adjustable time delay (10 seconds to 30 minutes)

Includes 2 Directional Shields

Weight: 2.3 oz (65.2 g)

Operating conditions: -4° to 131°F (-20° to 55°C);
5% to 95% RH, non condensing

Indoor use or outdoor use when installed in watertight lighting fixtures

UL and cUL listed, FCC approved

Five year warranty

MATERIALS

Polycarbonate, flame retardant

FACTORY DEFAULTS

Time Delay: 30 minutes

Sensitivity: Maximum

Light Level: 200 footcandles

COVERAGE AND DETECTION FEATURES

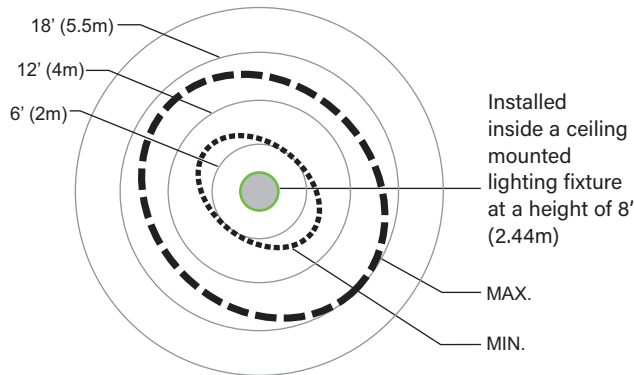

FM-105 ceiling mount coverage pattern.

The coverage pattern may vary based on sensor location and the characteristics of surrounding materials. Shield placement, or the use of the second shield, may also affect the coverage pattern.

Light Level Feature

The FM-105 also has daylighting control capability. The daylight control on the FM-105 is a "Hold-Off" type. The sensor stops

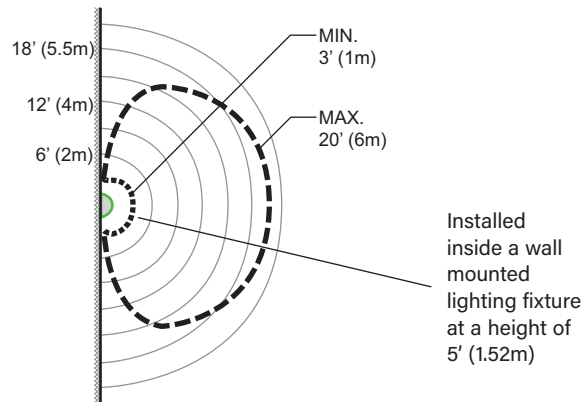

FM-105 wall mount side coverage pattern.

the load from turning on if the ambient light is greater than the daylighting setpoint. If the load is already on, the sensor will not turn off the load due to high ambient daylight. The FM-105 light level range is from 2 to 200 fc.

DIMENSIONS

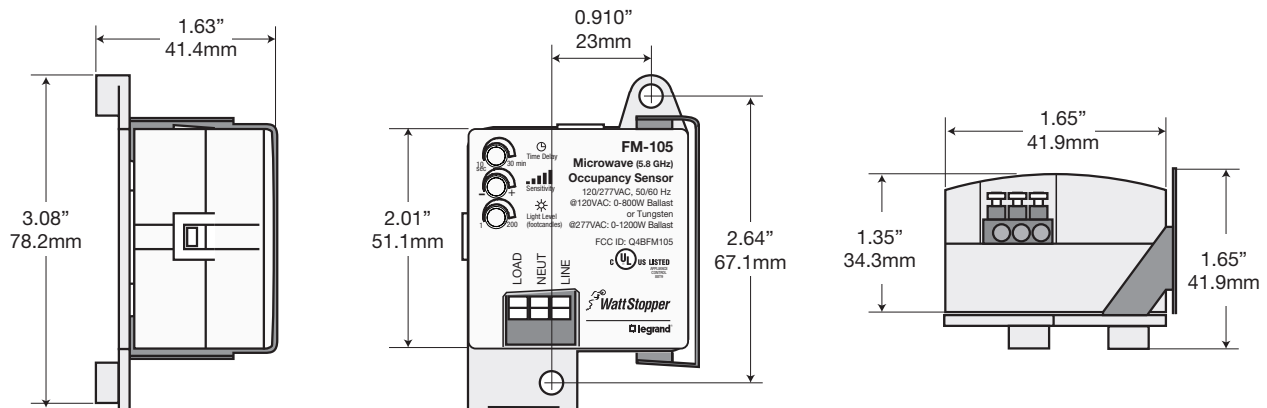

INSTALLING THE FM-105 SENSOR IN LIGHT FIXTURE

1. Determine the mounting location inside the luminaire or other suitable enclosure. If the daylight feature will be used, be sure to locate the sensor where daylight is not completely obscured from the sensor.
2. Attach the metal shield to the FM-105 so that the shield is located between the FM-105 and the lamp. Make sure that the wiring terminals on the FM-105 are accessible.
3. Put the plastic mounting foot onto the base of the FM-105 to secure the metal shield in place.
4. Secure the FM-105 assembly in place using screws through the plastic mounting foot.

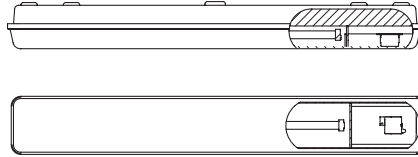

The FM-105 installs into the fixture and is invisible from view.

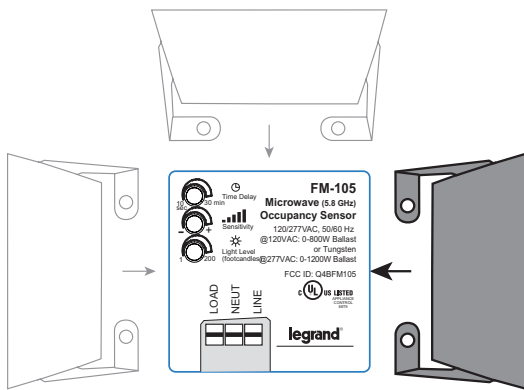

Position the metal shield between the sensor and the lamp.

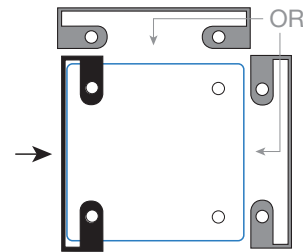

Bottom of FM-105

Align studs on the bottom of the FM-105 with the holes on the metal shield flanges. Do not block wiring terminals on the FM-105 with the shield.

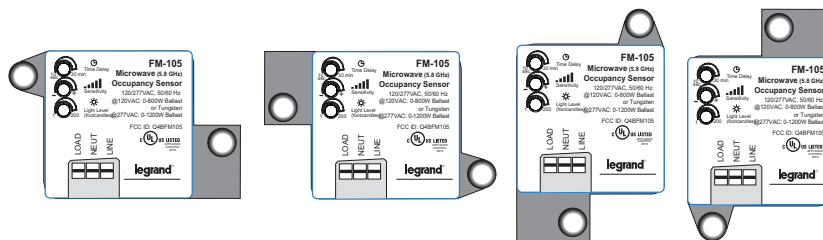

The plastic mounting foot can be oriented as needed, and accommodates an optional second shield in two positions.

WIRING DIAGRAMS

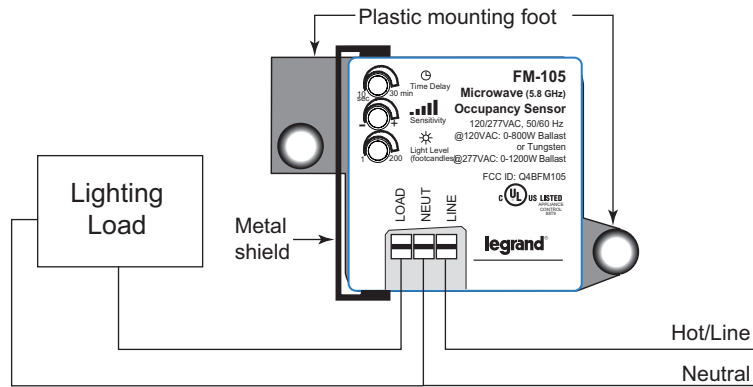

SEQUENCE OF OPERATION

It may take up to a minute for the sensor to warm up during the initial power-up. The sensor has an “instant on” feature. This occurs during installation or after a lengthy power failure only. As soon as power is supplied to the FM-105, the lights will come on and stay on for approximately 1 minute. If no movement is detected within that time the lights will turn off until detection occurs. If movement is detected during the initial 1 minute then the lights will stay on for whatever time has been set on the time delay.

ORDERING INFORMATION

Catalog #	Master Pack Details					Inner Pack Details				
	Master Pack Quantity	Case dimensions (inches)			Weight (pounds)	Inner Pack Quantity	Case dimensions (inches)			Weight (pounds)
		Length	Width	Height			Length	Width	Height	
FM-105	128	13.4	13.4	17.7	23.5	64	12.8	12.6	8.2	10

Catalog #	Color	Description	Input Voltage
<input type="checkbox"/> FM-105	White	Fixture mount, high frequency occupancy sensor with adjustable time delay and light level	120/277VAC, 50/60 Hz

The FM-105 may cause interference to a Wireless Network operating at a similar frequency around 5.8 GHz.

Information supplied above is subject to change.
 Harmonization code: 8538908080. Country of origin: China.

31628r1 Rev 08/2021