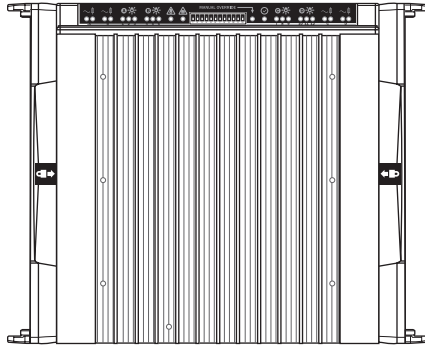

SDM12-EM • Les Numéros de Catalogue • Los Números de Catálogo:

Country of Origin: Made in China • Pays d'origine: Fabriqué en Chine • País de origen: Hecho en China

OVERVIEW

The SDM12 dimmer module provides control of up to 12 standard (forward phase) loads and up to 4 line feeds. The two additional line feeds provide added flexibility with AFCI circuit breakers compared to previous generation models. The modules have current sensing built-in allowing conditional programming in Design Center and increased support of Energy Management scenarios. SDM12 modules provide exceptional support of LED and CFL low wattage lighting as well as high wattage lighting. Vantage's easy plug-In and unplug installation, without removing any screws or wires, is now even easier with new locking mechanisms on either side of the module. The SDM module is compatible with new and old enclosures using new AC terminals (See *Module and Enclosure Examples* later in this document).

MODULE FEATURE SUMMARY

- Module provides forward-phase dimming, locking mechanism - insert/release handles
 - Locks module in enclosure and allows the module to be securely held when inserting and removing
- Each of the four line feed has replaceable fuses to protect the module; replacement fuses are available from Vantage (part # VCI-0038)
- Two spare fuses are provided with each module
- Supports up to 12 loads
- Separate AC termination boards eliminate the need for field wiring to the module
- Step-free ramping and dimming
- Support for LED lighting fixtures
- LED indicators; Line Power (1 per feed), Fuse Status (1 per fuse), Load Power (1 per load), Over Temperature, Overload, Manual Override, and Microprocessor Status,
- Automatic shutdown when over-temperature and overcurrent conditions are detected
- Self-powered
- In override, pre-program loads to any dim level
- TRIAC dimming
- Power consumption is measured for each line feed
- Firmware is field upgradeable

MODULE OPERATION

The SDM12-EM Standard Dimmer Module is designed for installation into new and older enclosures. Please note the following operational features:

- The module has a built-in 5W power supply; module remains powered and retains the last level for each load if the InFusion Controller is off line.
- **Primary Line feed (Line A) must be connected.**
- The SDM12-EM model has a relay on each load that switches OFF when the load is OFF preventing possible electrical noise feedback from the load's lighting fixtures. These relays also provide a 1000V air gap isolation between Line and Load when the relay is open.
- The large heat sink on the front is for heat dissipation; National Electrical Code requires that a minimum of 36 inches of clearance be maintained in front of the module.
- Over Temperature shutdown and indicator. If internal temperature reaches 105° C (221° F) the module shuts down and will not turn back on until the temperature has dropped to 90° C (194° F). If a module shuts down due to an over-temperature condition, it may be due to one or more of the following reasons:
 - a) The enclosure is blocked from allowing air to move through it (36" front clearance required),
 - b) The total wattage on one or more of the line feeds exceeds the maximum allowed, which would potentially overheat the module, and / or
 - c) The ambient room temperature is too high
- Overload shutdown and LED indicator: If this status LED is on, locate and fix the problem immediately. When fixed, cycle power to "Line A" or in Design Center right-click on the module and select *Reset Module*.

SPECIFICATIONS

Description	Specification
Dimensions, HWD	7.63" x 9.44" x 3.75" (194mm x 240mm x 95mm)
Weight	5.7 lbs (2.6 kg)
Ambient Operating Temperature	32° - 104°F (0 - 40°C)
Ambient Operating Humidity	5 - 95% non-condensing
Built-in Protection	Fuse protection per line, MOV surge, thermal shutdown, short circuit, snubber circuit
Cooling	Convection (enclosure must maintain 36" front clearance)
Chokes	12 EMI Suppression
Dimming Type	Forward-phase
LED Status Indicators	Line Power 1 Green per feed Fuse Status 1 Green per fuse Load Power 1 Red per load Over Temperature 1 Amber Overload 1 Amber Manual Override 1 Amber Microprocessor Status ** 1 Red
Manual Override	Load by Load Selectable
Lightning Surge Protection High-voltage	IEEE C62.41; (6000V and 3000A)
Lightning Surge Protection Low-voltage	ITU-T K.20
Maximum Amperage per Module	64A (7680W@120V), 64A (15,360W@240V), 64A (17,728W@277V)
Maximum Load per Line Feed	16A (1920W@120V), 16A (3840W@240V), 16A (4432W@277V)
Maximum Individual Load Amperage	16A (1920W@120V), 16A (3840W@240V), 16A (4432W@277V)
Maximum Individual LED Load Amperage	3.2A (384W @ 120V), 3.2A (768W@240V), 3.2A (886.4W@277V)
Maximum Transformer (Magnetic*) Load per Line Feed	1000VA@120V, 2000VA@240V, 2300VA@277V
Minimum Load	5W@120V, 12W@240V, 13W@ 277V
Load Types	Incandescent, LED, Dimmable CFL, Dimmable ballast, Magnetic Low-voltage, Neon/Cold Cathode (Ipf), Fluorescent (Relay mode only), Constant-speed motors (relay mode only)
Line Feeds	4 (20A Breakers maximum)
Loads	12
Voltage	120V/277V - 60/50Hz
SCCR Rating	65kA
System Compatibility	InFusion
FreeRTOS	Real-time scheduling provided by FreeRTOS (www.freertos.org)
Certifications	UKCA, CE, UL, cUL, EN 55032, EN 55035, EN 61000-3-2, EN 61000-3-3

*IMPORTANT MAGNETIC LOAD INFORMATION

- Connecting unloaded magnetic transformers should be avoided
 - Magnetic transformers should be appropriately sized
 - Magnetic transformers should not be overloaded or under loaded and should be operated near the rated capacity with an appropriate safety margin
- Magnetic transformers should be over current protected on the low-voltage side (fused or circuit breaker protection type)
 - For transformers that have dual secondary coils, each secondary should be equally loaded (e.g., Model EREA E212SC300SK transformer or similar)

MICROPROCESSOR STATUS LED

BLINK PATTERN	DESCRIPTION
Steady Blinking	Normal Communication
Rapid Blinking	No communication to Controller <ul style="list-style-type: none"> - Module not seated correctly - Controller not powered - Controller in Redboot - Incorrect wiring harness
Off	Module not powered or Line A not powered

FRONT LABEL / PANEL DESCRIPTION

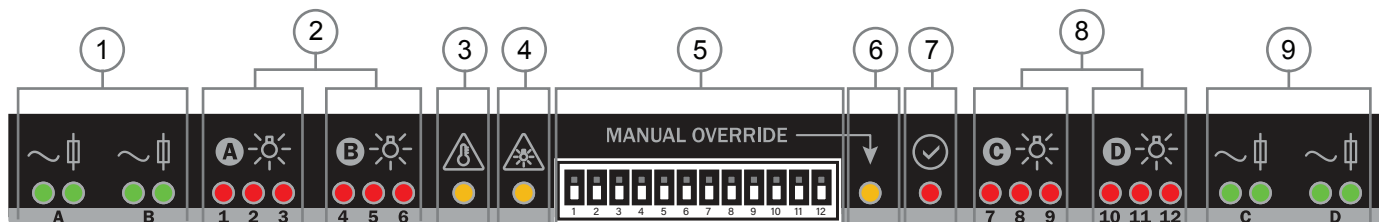

GREEN – Normal Operation

RED – On/Off Status for loads (numbers 2 and 8) and Blinking rates for processor status (number 7)

AMBER– Problem, needs attention when ON. If LED number 6 is ON and Manual Override was not intentionally enabled, please check the InFusion Controller to correct problem.

LEDs FOR 12 AND 8 LOADS:

1. Green LEDs for line-A/fuse-A and line-B/fuse-B
2. Red LEDs for loads 1 – 6
 - a. 8-load applications, load LEDs 1, and 4 are unused
3. Amber LED for over temperature
4. Amber LED for overload
5. Manual Override dip switches
6. Amber LED for Manual Override
7. Red steady blinking LED for module processor status
 - a. Rapid blinking when no communication with controller
8. Red LEDs for loads 7 – 12
 - a. 8-load applications, load LEDs 7 and 10 are unused
9. Green LEDs for line-C/fuse-C and line-D/fuse-D

INSTALLATION

Installation of Vantage products should be performed or supervised by a Certified Vantage Installer. Installation and maintenance of high-voltage devices should only be performed by licensed, qualified, and competent personnel having appropriate training and experience.



**WARNING: TURN THE POWER OFF AT THE
CIRCUIT BREAKER BEFORE WIRING.**



CAUTION: Turn Breakers **OFF** and check that no power is ON at the AC Terminal Boards when working in the enclosure or working on lighting fixtures connected to the module's loads, etc. Do not allow trimmed wire cuttings to fall into enclosure components as they may cause damage when power is restored. Damage from this type of short will void the warranty.

BEFORE MODULE IS PLUGGED IN: All AC wiring must be terminated into AC screw terminal connectors. Vantage recommends installing MJTB jumper boards to pre-test* the wiring and to allow the module to be installed after construction is complete; this eliminates the chance of a module being damaged during the testing and construction phase.

***PRE-TESTt:** Not testing with the MJTB jumper could void the module's warranty (Please see the Testing and Pre-Installation of Module section later in this document).

TORQUE: It is very important to have the proper torque on all AC connections.

CONNECTIONS

CONNECTOR	DESCRIPTION	WIRE RANGE
Module Terminal	20 Inch Pounds	14-10 AWG*
Controller Power	20 Inch Pounds	14-10 AWG*
*Must match breaker wire gauge Copper Wire Only - Minimum 80°C Insulation		

NEUTRALS: Run a separate NEUTRAL for each load connected to dimming devices. Failure to do this may cause static loads to slightly flicker while other loads, sharing the same neutral, are ramping or fading.

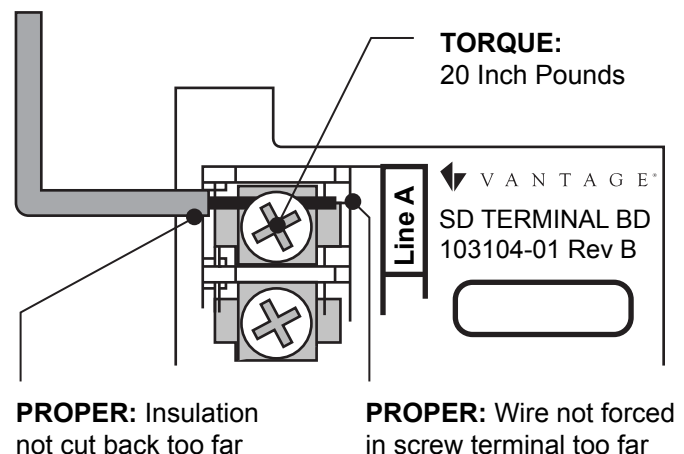

LOCKING MECHANISM - MODULE INSERTION AND EXTRACTION PROCESS

STOP! ALWAYS TURN BREAKERS OFF WHEN INSERTING OR EXTRACTING ANY MODULE! VERIFY POWER IS OFF WITH A RELIABLE METER BEFORE PROCEEDING!

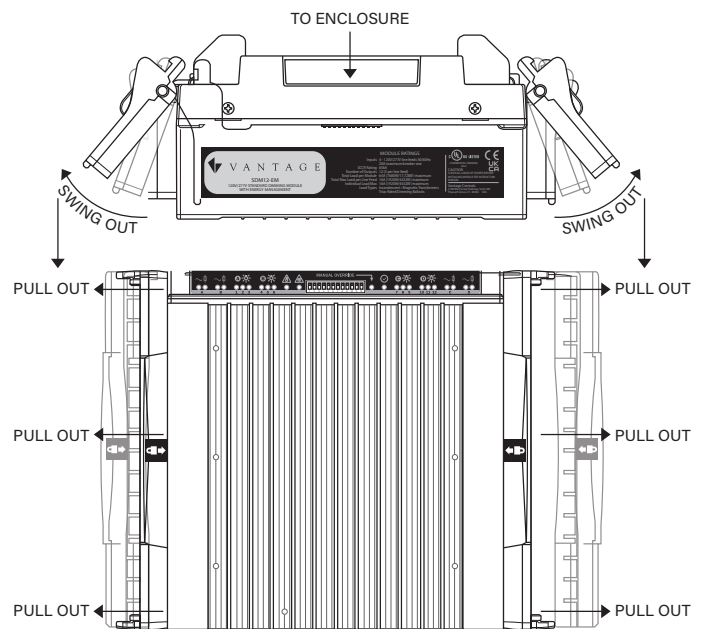
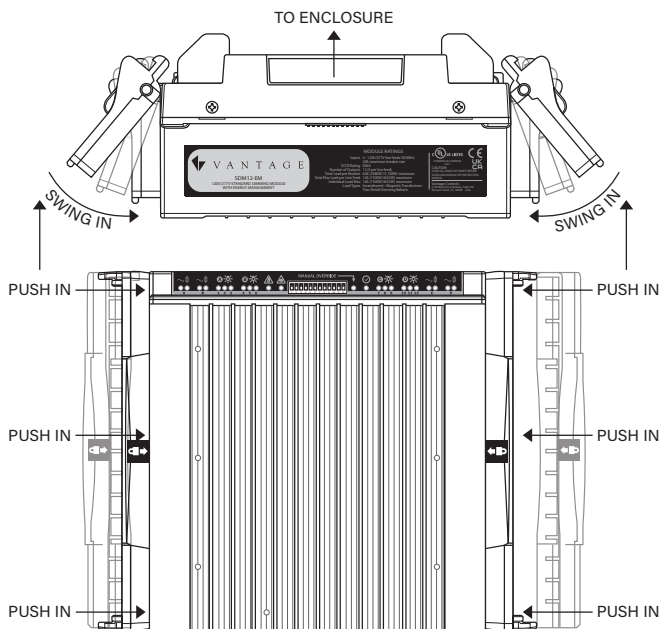

INSERTION STEPS

1. Turn all breakers off to the module's line feeds – verify!
2. Be sure the handles are fully spread out/apart.
3. Grip the handles and carefully line up the module with AC terminal boards
4. Push module into enclosure by applying pressure to the heat sink with your palms and at the same time allowing the handles to swing in – toward the module.
5. When the module is fully seated, make sure the handles are fully pressed in to the module sides, to properly lock.

EXTRACTION STEPS

1. Turn all breakers off to the module's line feeds – verify!
2. Grip the handles and spread apart. The locking handles are designed to lift the module free.
3. When the handles are fully spread apart the module has been extracted from the AC terminals and is free – securely hold both handles until the module is set aside.

FUSE REPLACEMENT

CAUTION: TURN BREAKERS OFF! VERIFY POWER IS OFF WITH METER!

FUSE REPLACEMENT

Fuse LED indicator is ON when the fuse is working.

Remove module from the AC panels by pulling the locking handles apart to raise module (see *Locking Mechanism - Module Insertion and Extraction Process* above.)

Carefully follow the steps below to replace the bad fuse with a replacement fuse. Note the location of fuse holders on the back of module. Two spare fuses are shipped with each module. Spare fuses may be ordered from Vantage, part # VCI-0038. Module design allows for four spare fuses.

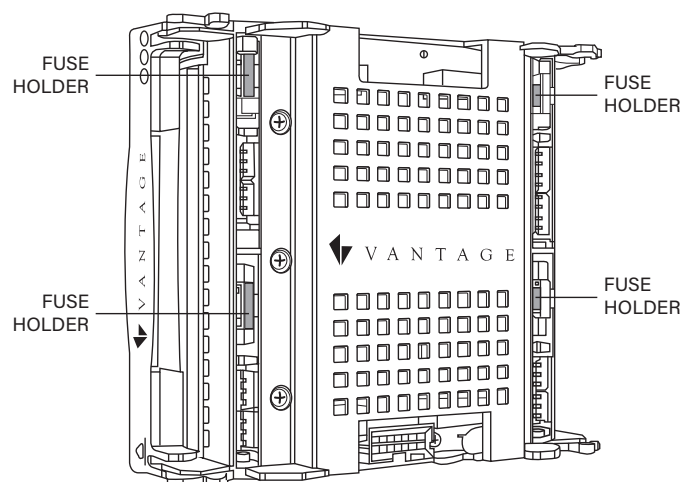

STEPS TO REPLACE FUSE

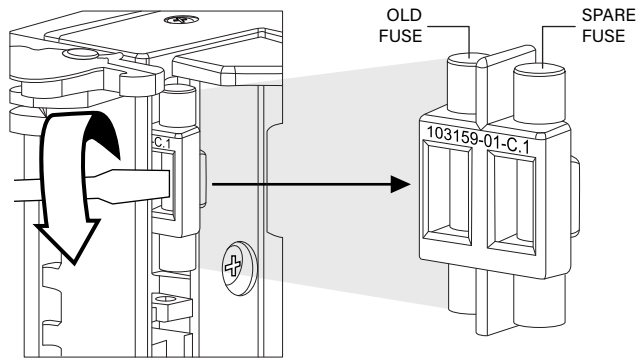

1. Use a wide, flat blade screwdriver or pliers to carefully lift/pull the fuse holder component out of the module. Use caution to avoid damage to the spare fuse and/or fuse holder in this step.

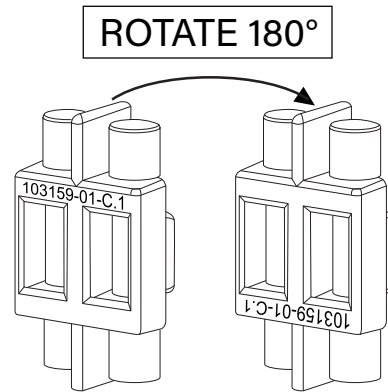

2. Rotate the fuse holder component 180 degrees as illustrated.

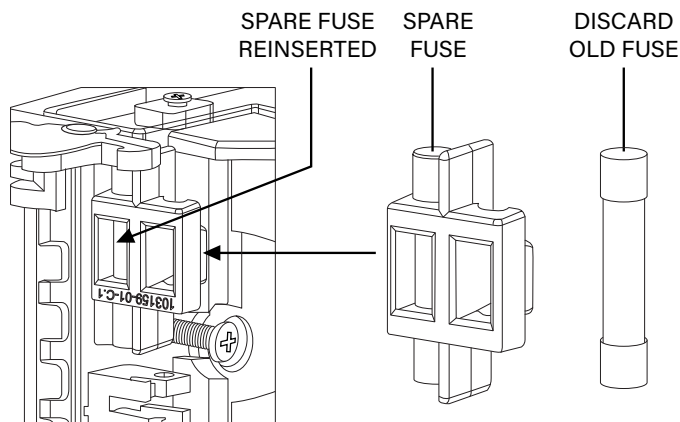

3. Remove the old fuse and discard. Carefully reinsert the fuse holder, using care that it is securely inserted making a solid connection.

4. After Fuse Replacement and Before Applying Power:

- Make sure fuse is secure and centered top to bottom in the fuse clamps
 - The metal fuse ends must fully line up with the fuse clamps for maximum surface contact between clamps and use end conductors
- Make sure fuse clamps in module are not bent allowing the fuse to be loose
- If fuse clamps are loose:
 - **DO NOT PLUG MODULE IN**
 - Remove fuse holder again
- Carefully squeeze fuse clamps closer together (not too hard) so fuse holds tight. **Do not over squeeze!**
- Reinsert fuse assuring maximum surface contact

TESTING AND PRE-INSTALLATION OF MODULE

CAUTION: Turn line feed breakers OFF before installing MJTB jumper boards! Using a reliable meter, verify that the power is OFF! Vantage’s MJTB jumper should be used to test* all loads for shorts before modules are plugged in. The jumper may also be used during construction providing control of loads via circuit breakers.

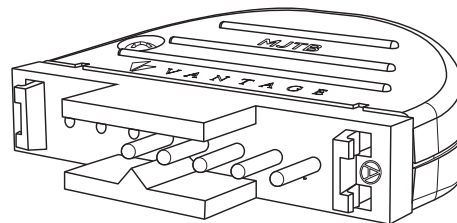

***NOTE:** Vantage recommends the practice of installing this product to help test the wiring and loads before modules are plugged in. Failure to properly ensure that all wiring is correct and free of shorts, before connecting modules, is the responsibility of the Vantage installer and/or the licensed electrician. Modules and other components damaged as a result of incorrect wiring and/or incorrect loads, etc. will not be covered by the module’s warranty.

MODULE AND ENCLOSURE EXAMPLES

AC TERMINAL BOARDS ASSEMBLY • NEW / OLD ENCLOSURES

With new enclosures the AC terminal boards are installed in the field. This allows more flexibility in mixing module models inside each enclosure. Select the correct parts for each example:

SCENARIO EXAMPLES	AC TERMINAL KITS
1. New SDM12-EM module into new enclosure	TSDM-KIT (TSDM-L (GND) / TSDM-R)
2. New SDM12-EM module into old enclosure - <i>Retrofit</i>	TROSDM-KIT (TROSDM-L (GND) / TROSSDM-R) TROSDM-P-KIT (TROSDM-L (GND) / TROSSDM-R) -OR- TSDM-P-KIT (12 Load Retrofit) (TSDM-L (GND) / TSDM-R / 103160-1)

IMPORTANT

The LEFT AC Terminal board, TSDM-L and TROSDM-L (Retrofit), is the module’s ONLY ground source. Make sure the **center** screw is properly connected and grounded.

EXAMPLE 1: NEW SDM12-EM MODULE INTO NEW ENCLOSURE

ENCLOSURE AC PANEL BOARD ASSEMBLY FOR SDM12-EM MODULE

1. Insert AC terminal boards– TSDM-L left and TSDM-R right to panel board and secure using 1, VHD-0082, #6-32 X 7/8” PHILLIPS PAN HEAD THREAD FORMING screws (TYPE-F) on each board.

a. Left board is also the ground connection for the SDM12-EM module – it must connect to the enclosure – be careful not to strip self-tapping threads or damage AC terminal board.

2. Place module load labels on left and right sides of the AC panel board using care to align with screw terminals.

3. Enclosure section is now ready for wiring.

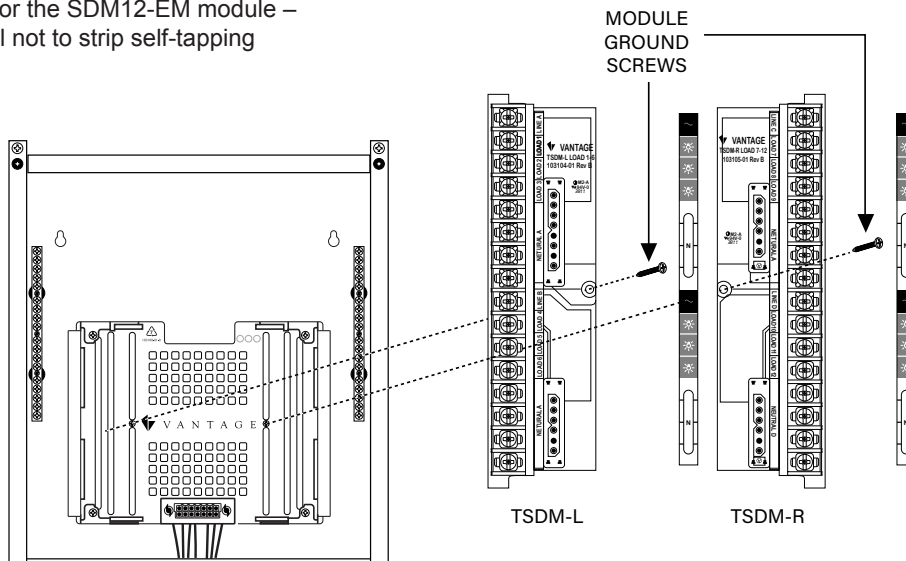

EXAMPLE 1B: 12 LOAD WIRING SDM12-EM - NEW ENCLOSURE

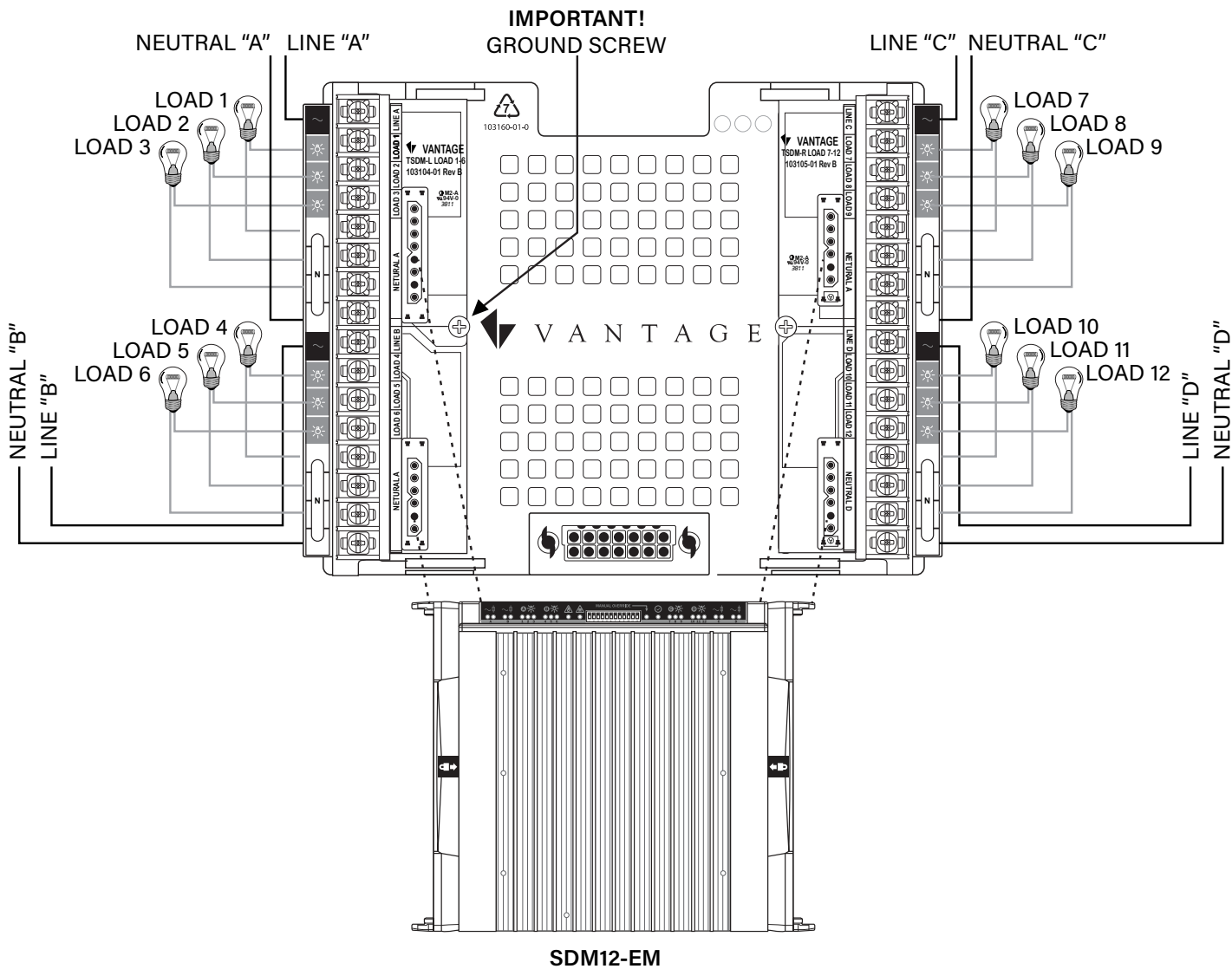

EXAMPLE 2: NEW SDM12-EM MODULE INTO OLD ENCLOSURE - RETROFIT

Please note when replacing an old module, Model, MDS8RW101-201 with a new module use the retrofit AC terminal boards. Order kit, part number: TROSDM-KIT or TROSDM-P-KIT, (the later comes with the 103160-1 panel board). Both kits include the Left: TROSDM-L and Right: TROSDM-R. Line Feed B and Line Feed D are ignored using these retrofit AC boards. Note that the SDM12-EM module only utilizes 8 loads in a retrofit installation. It is possible to replace the module without making a change in the Design Center file unless you want to select LEGACY mode and use the currentsensors. Physically wire all loads to same load position as on the old module. Please use dip-switches 2, 3, 5, and 6 for left loads and 8, 9, 11, and 12 for right loads.

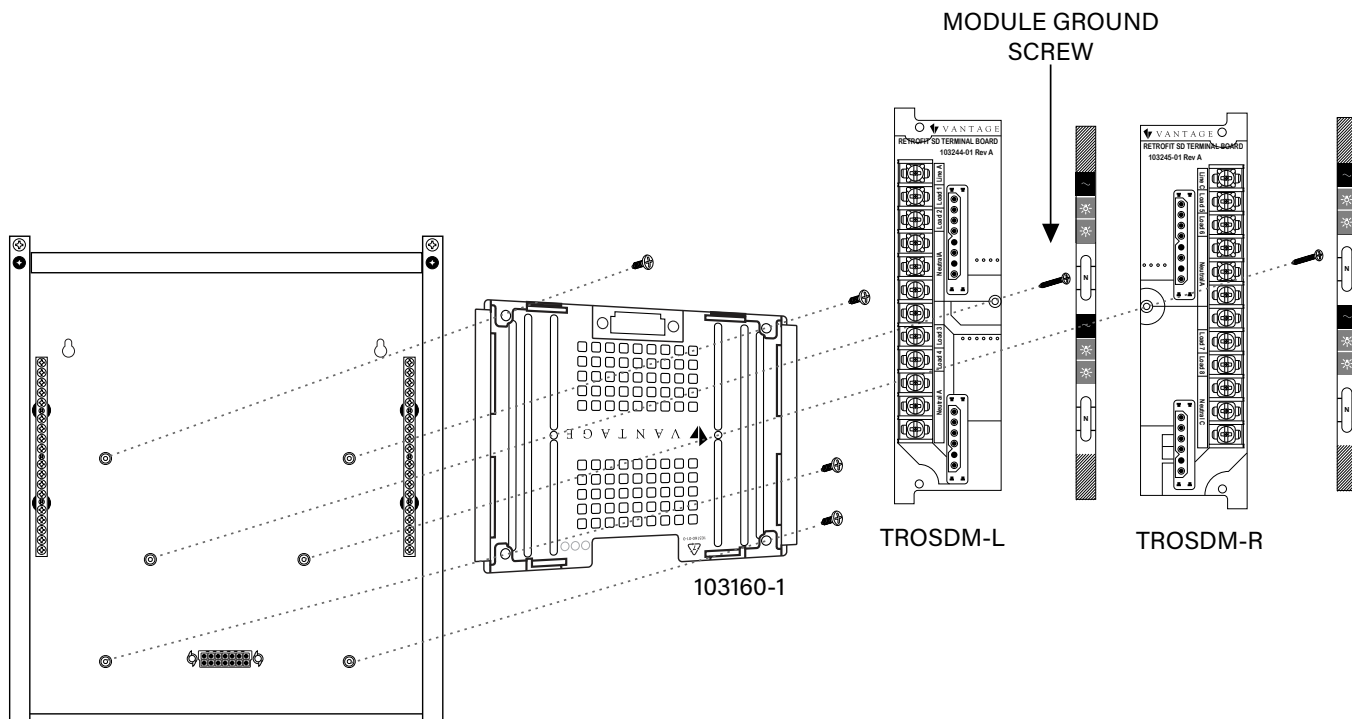

AC TERMINAL BOARD ASSEMBLY FOR SDM12-EM MODULE IN OLD ENCLOSURE

1. Remove old AC terminal boards and plastic standoffs*.
2. Install new screw panel board – inserted upside down. If placing next to an old module, it will be necessary to trim the clear plastic inter-lock** sections of the old plastic panels in the enclosure to make room for the new 103160-1, panel board. This will need to be done at any location where the new panel board is next to an old module. See illustration (below).

NOTE: If the enclosure pre-dates the plastic standoffs (enclosures shipped before February 2005) and uses pem-studs (metal standoffs) instead, the new panel, part #103160-1, is not needed. Simply remove the old AC terminal boards and metal spring clips. Replace with the retrofit AC terminal boards, TROSDM-KIT, using all three screws from old AC boards.

3. Insert AC terminal boards - Left: TROSDM-L and Right: TROSDM-R to panel board and secure using, VHD-0082, #6-32 X 7/8" PHILLIPS PAN HEAD THREAD FORMING screw (TYPE-F) on each board.
4. Place module load labels on left and right sides of the AC panel board using care to align with screw terminals (labels are not used with pem-stud type enclosures).
5. Enclosure section is now ready for wiring.

New SDM12-EM module into old enclosure-retrofit - Retrofit 8 Load Wiring • SDM12-EM • Old Enclosure (old enclosure part numbers, MPER(S)/SPER(S) -2/4-(IC36/24) or CMPER/CSPER(S) -2/4-(IC36/24)

A *Legacy Mode* check box is shown in the *Object Editor* when the new module is being placed in an old enclosure. Uncheck or check this box to change the number of loads to 8 or 12.

EXAMPLE 2B: 8 LOAD WIRING LEGACY MODE

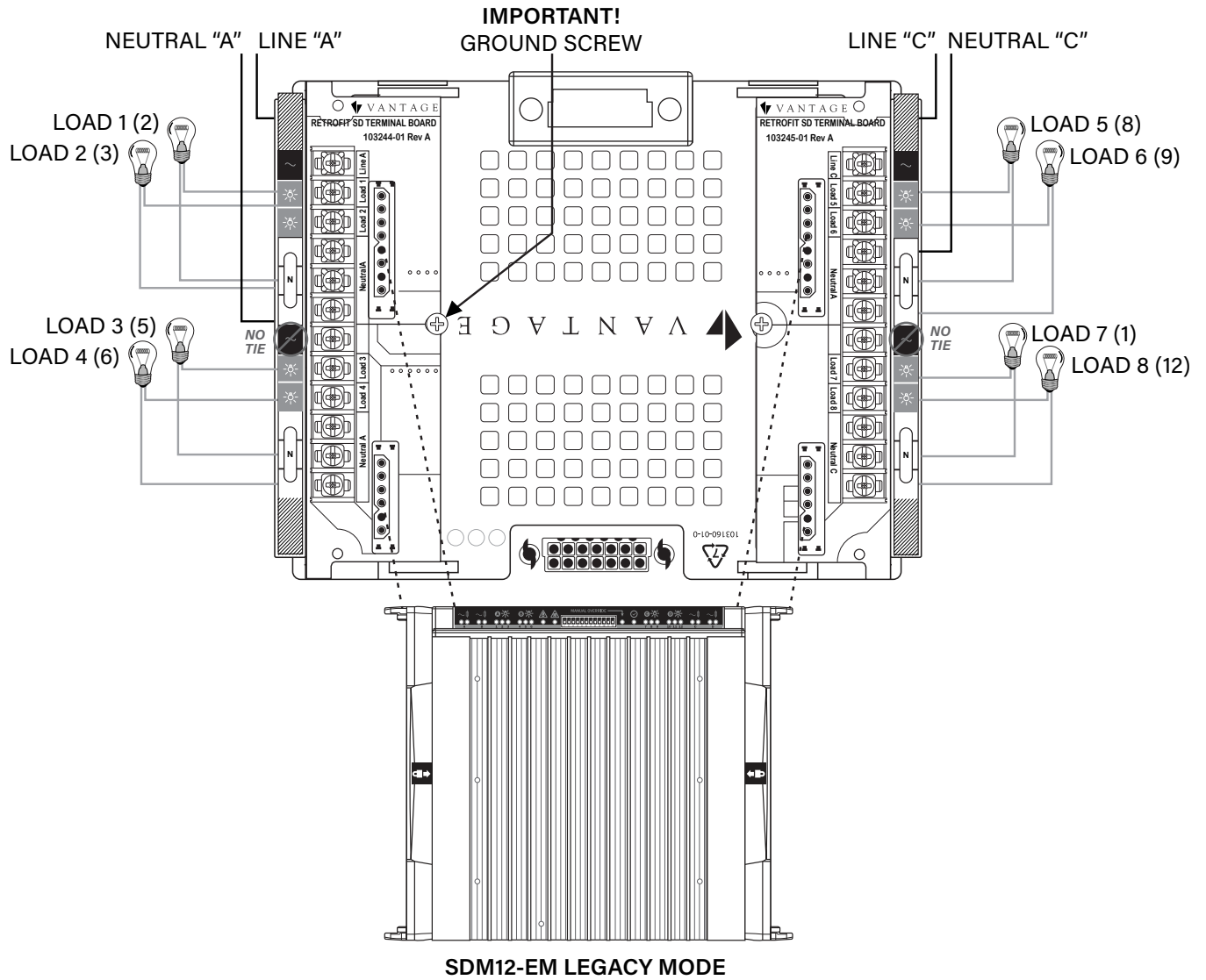

**Mixed installations with new and old modules next to each other in an older enclosure.

REMOVING THE INTERLOCK KEY

The interlock key on the old plastic standoffs will not allow the new plastic screw panel 103160-1 to fit properly and must be trimmed. **NOTE:** This interlock key is typically on the top of the plastic standoffs for left-hand side and on the bottom for the right hand side.

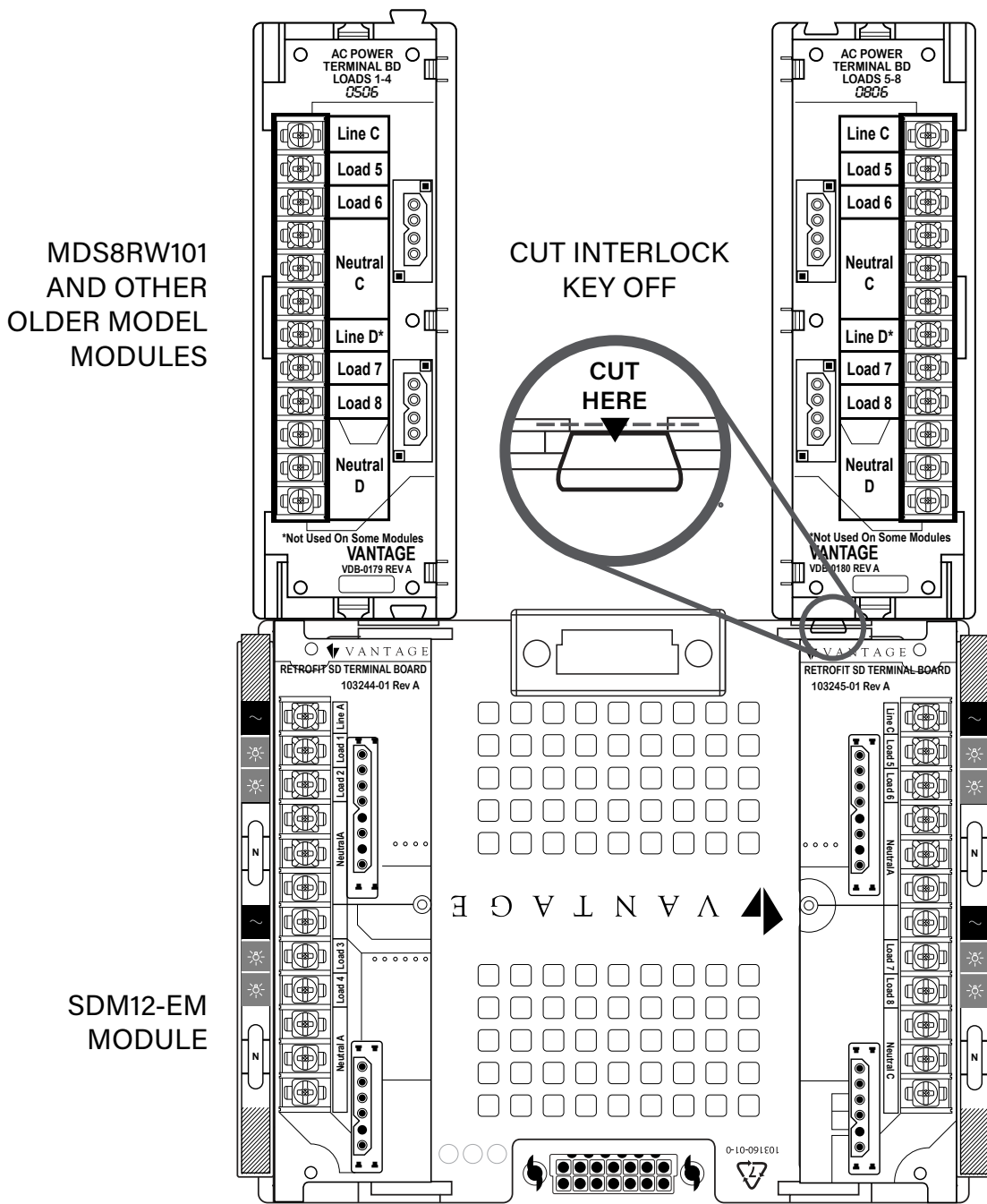

ENERGY MANAGEMENT AND SENSORS

Each module has a built-in temperature sensor and current sensing is built into each of the four line feeds. Design Center can monitor and report the line feed measurements in AMPS and/or WATTS. This information may be used in energy management scenarios to conserve the amount of energy used at any given time.

POWER/CURRENT SENSOR TRACKING

In Design Center, notice when the new module is selected in Enclosure View the Object Editor displays each of the power and current sensors separately. This allows the programmer to place a checkmark in the Track checkbox which allows live, continuous tracking of the line feed’s power consumption. It is recommended to only place a check mark in sensors that will be tracked “live” via a TPT Touchscreen. It is still possible to program energy management scenarios without the sensors having the Track checkbox, checked.

Program, using the “IF” logic to compare AMPS and/or WATTS to perform load shedding / load on limiting tasks. It is also possible to program energy management scenarios using load on percentages. Any combination of power/current sensor and load percentages may be used to shed loads for power shedding requirements.

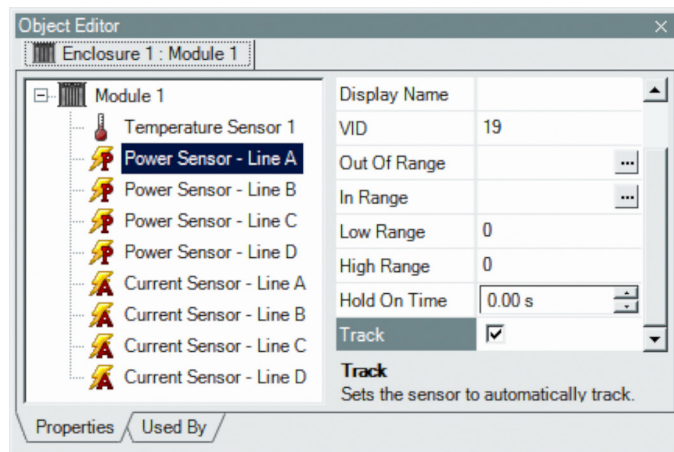

FIRMWARE UPDATE

From Design Center, click on *System | Update Firmware | Update Module Firmware* to open the window below. Place a check mark on a controller or enclosure for all modules of the same type to be updated or place individual check marks for each individual module to be updated. The firmware file is automatically selected by Design Center, however a Browse, button is available for manually selecting the firmware. Click *Start* and the Firmware Update utility will automatically update every module that has a check mark – one at a time. A confirmation check mark is placed in front of each module successfully updated or a red X if the update failed.

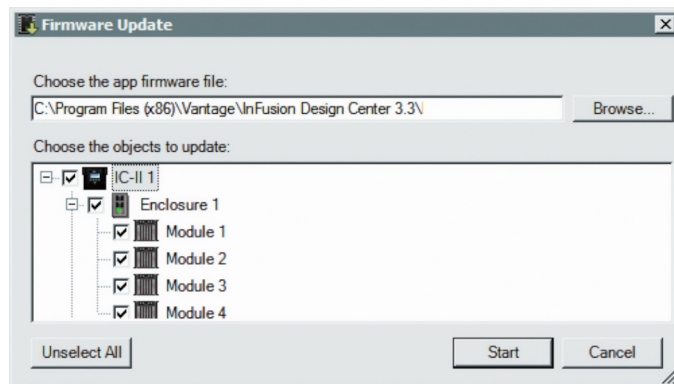

NOTE: A new SDM12-EM module in an old enclosure with no change in the Design Center file – Design Center still shows the old module – will not show up in the update list above. To update a new module, in this scenario, requires a temporary Design Center file with the new module model in the same enclosure position as the old module. Once the update is complete, the original file is again downloaded to the controller.

VANTAGE AC TERMINAL BOARD KITS

KIT MODELS	DESCRIPTION
Each KIT Contains:	• One set of load labels • Two #6-32 X 7/8” (TYPE-F) screws
TSDM-KIT	• One TSDM-L (12 load, left board) • One TSDM-R (12 load, right board)
TROSDM-KIT (Retrofit Applications)	• One TROSDM-L (8 load, left board) • One TROSDM-R (8 load, right board)
TROSDM-P-KIT (Retrofit Applications)	• One TROSDM-L (8 load, left board) • One TROSDM-R (8 load, right board) • One AC PANEL board, 103160-1
TROSDM12=P=KIT (Retrofit Applications)	• One TSDM-L (12 load, left board) • One TSDM-R (12 load, right board) • One AC PANEL board, 103160-1
INDIVIDUAL MODELS	DESCRIPTION
TSDM-L	• One 12 load, left board
TSDM-R	• One 12 load, right board
TROSDM-L (Retrofit)	• One 8 load, left board
TROSDM-R	• One 8 load, right board

PRODUCT DRAWINGS

NEW PANEL BOARD
103160-1

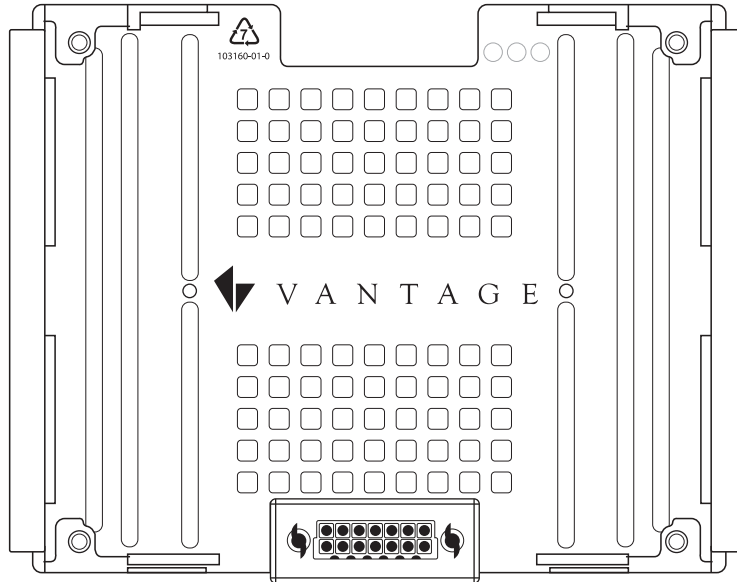

12 LOAD AC BOARDS KIT - TSDM-KIT
(TSDM-L Left and TSDM-R Right)

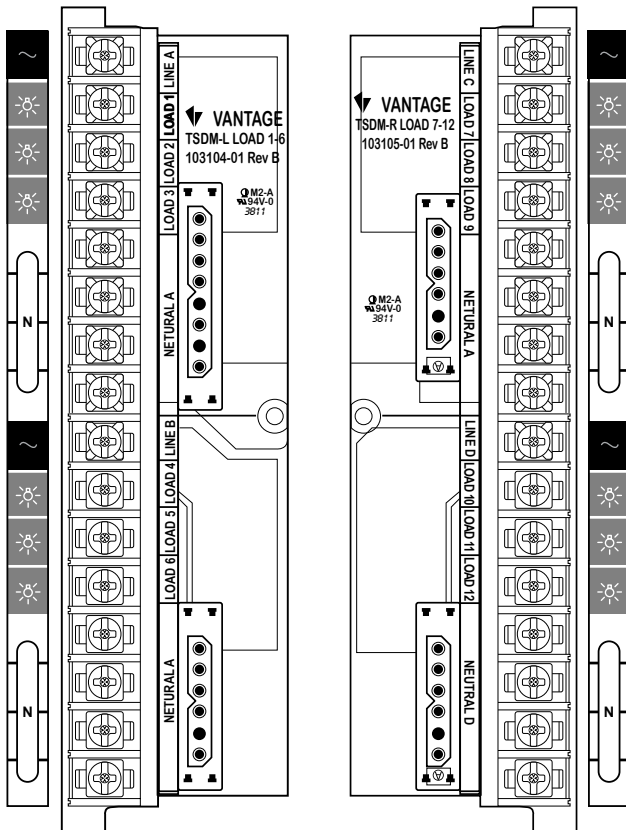

8 LOAD RETROFIT AC BOARDS KIT - TROSDM-KIT
(TROSDM-L Left and TROSDM-R Right)

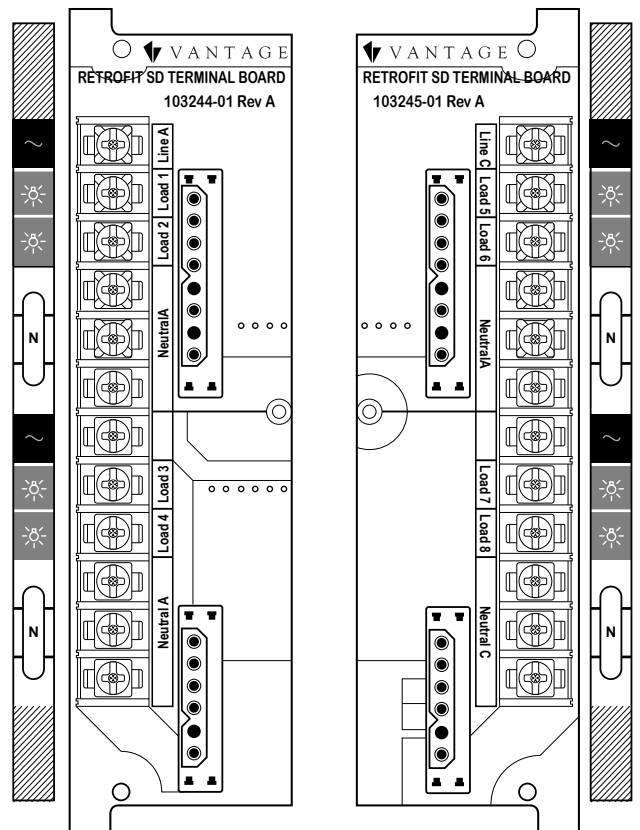

MULTI-VIEW LINE DRAWINGS

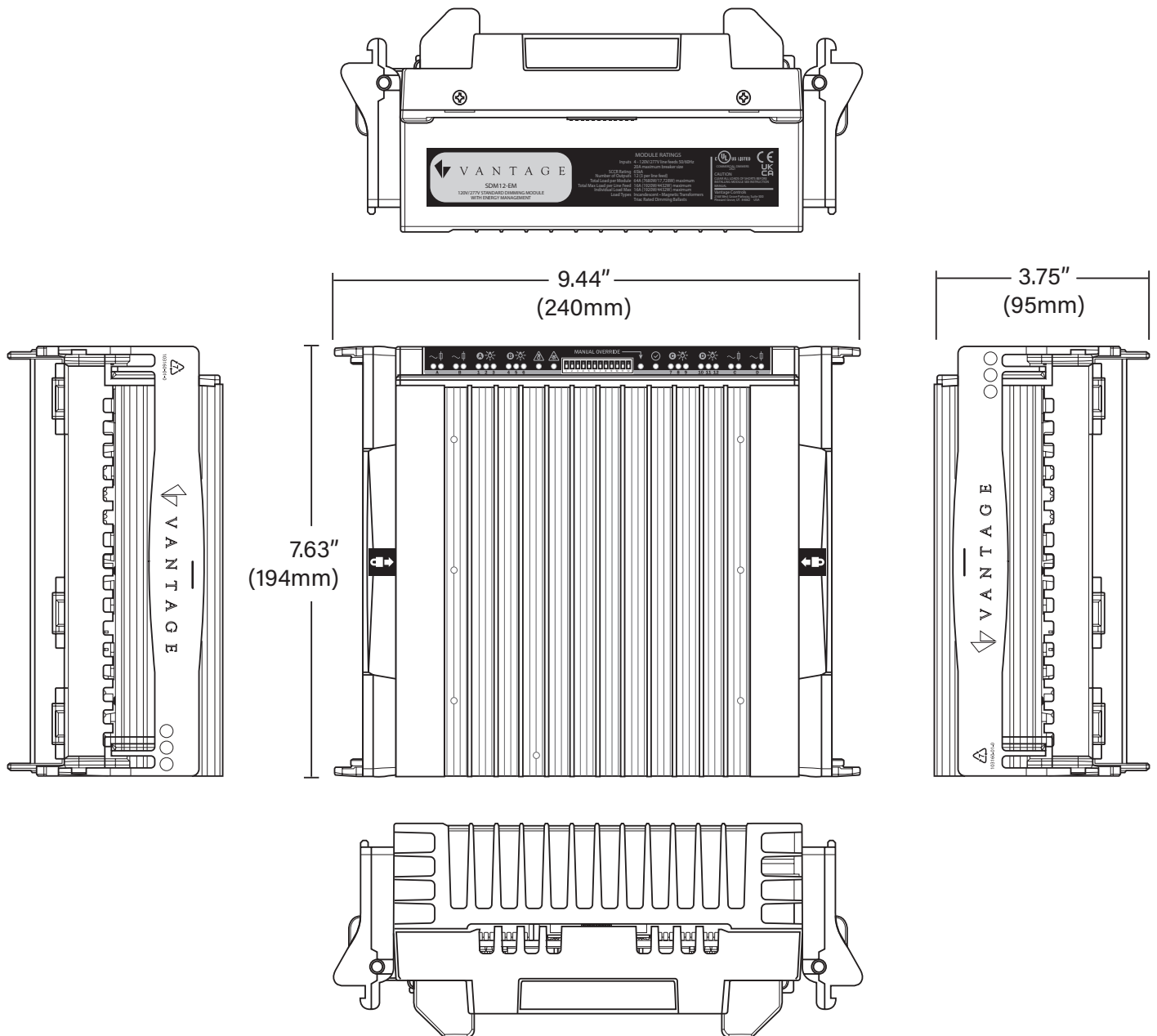

WARRANTY INFORMATION

Vantage warrants its products to be free of defects in materials and workmanship for a period of five (5) years. There are no obligations or liabilities on the part of Vantage for consequential damages arising out of, or in connection with, the use or performance of this product or other indirect damages with respect to loss of property, revenue or profit, or cost of removal, installation or reinstallation.

INFORMATIONS RELATIVES À LA GARANTIE

Vantage garantit que ses produits sont exempts de défauts de matériaux et de fabrication pour une période de cinq (5) ans. Vantage ne peut être tenu responsable de tout dommage consécutif causé par ou lié à l'utilisation ou à la performance de ce produit ou tout autre dommage indirect lié à la perte de propriété, de revenus, ou de profits, ou aux coûts d'enlèvement, d'installation ou de réinstallation.

INFORMACIÓN DE LA GARANTÍA

Vantage garantiza que sus productos están libres de defectos en materiales y mano de obra por un período de cinco (5) años. No existen obligaciones ni responsabilidades por parte de Vantage por daños consecuentes que se deriven o estén relacionados con el uso o el rendimiento de este producto u otros daños indirectos con respecto a la pérdida de propiedad, renta o ganancias, o al costo de extracción, instalación o reinstalación.