



WIREMOLD®

6000® Series Raceway

Chemin de câbles de série 6000®

Conducto eléctrico serie 6000®

No: 41401R3 0418

Installation Instructions • Notice d'Installation • Instrucciones de Instalación

Catalog Number(s) • Numéro(s) de catalogue • Número(s) de catálogo: 660B, 640C, 6000B-10, 6000WC, 6001, 6001DA, 6006, 6007C-1, 6007C-2, 6008A, 6010B, 6011TX, 6012TX, 6014A, 6017TX, 6074, 6074A, 6086, 6046KD

Country of Origin • Pays d'origine • País de origen: Made in USA • Fabriqué aux USA • Hecho en USA

IMPORTANT:

Please read all instructions before beginning installation

Legrand electrical systems conform to and should be properly grounded in compliance with requirements of the current National Electrical Code or codes administered by local authorities.

All electrical products may present a possible shock or fire hazard if improperly installed or used. Legrand electrical products may bear the mark of a Nationally Recognized Testing Laboratory and should be installed in conformance with current local and/or the National Electrical Code.

NOTE:

All unblocked openings intended for wiring devices, fittings or accessories must be closed off by appropriate wiring devices, fittings or accessories prior to initial circuit energization.

IMPORTANT :

Veillez lire l'ensemble des instructions avant de commencer l'installation.

Les systèmes électriques Legrand sont conformes au Code National de l'électricité (National Electrical Code) ou aux codes locaux en vigueur et doivent être mis à la terre conformément à ces codes.

Tous les produits électriques peuvent présenter un risque d'électrocution ou d'incendie s'ils ne sont pas installés ou utilisés correctement. Les produits électriques Legrand peuvent porter la marque d'un laboratoire reconnu et doivent être installés conformément au Code national de l'électricité et/ou aux codes locaux en vigueur.

Remarque :

Toutes les ouvertures non bloquées destinées aux câbles, aux raccords ou aux accessoires doivent être fermées par des dispositifs de câblage, des raccords ou des accessoires appropriés avant l'activation du circuit initial.

IMPORTANTE:

Lea todas las instrucciones antes de comenzar la instalación.

Los sistemas eléctricos Legrand cumplen con los requisitos del Código Eléctrico Nacional (National Electrical Code, NEC) actual o con los códigos impuestos por las autoridades locales y deben conectarse a tierra consecuentemente.

Todos los productos eléctricos pueden presentar un riesgo de descarga o incendio si se los instala o utiliza incorrectamente. Los productos eléctricos Legrand pueden llevar la marca de un laboratorio de pruebas reconocido a nivel nacional y se deben instalar conforme al código local en vigencia o al Código Eléctrico Nacional.

Nota:

Todas las aperturas desbloqueadas de los dispositivos de cableado, equipamiento o accesorios deben cerrarse con los dispositivos de cableado, equipamiento o accesorios adecuados antes del suministro inicial de energía al circuito.

6000 SERIES RACEWAY WIRE FILL CAPACITIES FOR COMMUNICATIONS

TYPE	UNSHIELDED) TWISTED PAIR		TELEPHONE 24 AWG, No. of Pairs				COAXIAL				TWINAXIAL	SHIELDED TWISTED PAIR			FIBER OPTIC
	CAT 5	CAT 3	2	3	4	25	RG58/U	RG59/U	RG62/U	RG6/U	100 OHM	TYPE 1	TYPE 2	TYPE 3	Two Strand (Duplex) Multimode, 62.5/125µm
O.D. Inches	0.220	0.190	0.140	0.150	0.190	0.410	0.195	0.242	0.242	0.270	0.330	0.390	0.465	0.245	0.190
O.D. (mm)	(5.6)	(4.8)	(3.6)	(3.8)	(4.8)	(10.4)	(5.0)	(6.1)	(6.1)	(6.9)	(8.4)	(9.9)	(11.8)	(6.2)	(4.8)
40% FILL Divided	80	107	198	172	107	23	102	66	66	53	35	25	17	64	107
40% FILL Undivided	161	217	399	348	217	46	206	133	133	107	71	51	36	139	217

* Category 6 augmented (6a) cable for 10 gigabit ethernet – max allowed cable diameter per addenda No. 11 ANSI TIA/EIA 568-B.2.

6000 SERIES RACEWAY WIRE FILL CAPACITIES FOR POWER WITH DEVICES

TYPE AWG, THHN/THWN	2/0	1/0	1	2	4	6	8	10	12	14
O.D. Inches	0.532	0.486	0.446	0.384	0.324	0.254	0.216	0.164	0.130	0.111
O.D. (mm)	(13.5)	(12.3)	(11.3)	(9.8)	(8.2)	(6.5)	(5.5)	(4.2)	(3.3)	(2.8)
40% FILL Divided	14	17	20	27	38	62	86	149	237	325
40% FILL Undivided	28	34	40	54	76	125	173	300	475	652

6000 SERIES RACEWAY WIRE FILL CAPACITIES FOR POWER WITHOUT DEVICES

TYPE AWG, THHN/THWN	2/0	1/0	1	2	4	6	8	10	12	14
O.D. Inches	0.532	0.486	0.446	0.384	0.324	0.254	0.216	0.164	0.130	0.111
O.D. (mm)	(13.5)	(12.3)	(11.3)	(9.8)	(8.2)	(6.5)	(5.5)	(4.2)	(3.3)	(2.8)
40% FILL Divided	11	14	16	22	31	51	71	123	195	268
40% FILL Undivided	22	26	31	43	60	98	135	235	373	512

NOTE: Use No. 8 (5/16", 7.9mm head size) flat head fastener or equivalent to mount base to surface.

NOTE: Grounding: Use ground location when provided or install a suitable ground lug, ring terminal or locknut and ground bushing.

CAPACITÉS DE REMPLISSAGE DU CHEMIN DE CÂBLES DE SÉRIE 6000 POUR LES CÂBLES DE COMMUNICATION

TYPE	PAIRE TORSADÉE NON BLINDÉE		TÉLÉPHONE 24 AWG, Nombre de paires				COAXIAL				TWINAXIAL	PAIRE TORSADÉE BLINDÉE			FIBRE OPTIQUE
	CAT 5	CAT 3	2	3	4	25	RG58/U	RG59/U	RG62/U	RG6/U	100 OHM	TYPE 1	TYPE 2	TYPE 3	Deux brins (Duplex) Multimode, 62.5/125µm
Diam. ext. (pouces)	0,220	0,190	0,140	0,150	0,190	0,410	0,195	0,242	0,242	0,270	0,330	0,390	0,465	0,245	0,190
Diam. ext. (mm)	(5,6)	(4,8)	(3,6)	(3,8)	(4,8)	(10,4)	(5,0)	(6,1)	(6,1)	(6,9)	(8,4)	(9,9)	(11,8)	(6,2)	(4,8)
40 % DE REPLISSAGE Divisé	80	107	198	172	107	23	102	66	66	53	35	25	17	64	107
40 % DE REPLISSAGE Non divisé	161	217	399	348	217	46	206	133	133	107	71	51	36	139	217

* Câble de catégorie 6 améliorée (6a) pour 10 gigabit Ethernet – diamètre maxi du câble autorisé selon l'addenda n° 11 ANSI TIA/EIA 568-B.2.

CAPACITÉS DE REMPLISSAGE DU CHEMIN DE CÂBLES DE SÉRIE 6000 POUR PUISSANCE ÉLECTRIQUE AVEC APPAREILS

TYPE AWG, THHN/THWN	2/0	1/0	1	2	4	6	8	10	12	14
Diam. ext. Pouces	0,532	0,486	0,446	0,384	0,324	0,254	0,216	0,164	0,130	0,111
Diam. ext. (mm)	(13,5)	(12,3)	(11,3)	(9,8)	(8,2)	(6,5)	(5,5)	(4,2)	(3,3)	(2,8)
40 % DE REPLISSAGE Divisé	14	17	20	27	38	62	86	149	237	325
40 % DE REPLISSAGE Non divisé	28	34	40	54	76	125	173	300	475	652

CAPACITÉS DE REMPLISSAGE DU CHEMIN DE CÂBLES DE SÉRIE 6000 POUR PUISSANCE ÉLECTRIQUE SANS APPAREILS

TYPE AWG, THHN/THWN	2/0	1/0	1	2	4	6	8	10	12	14
Diam. ext. Pouces	0,532	0,486	0,446	0,384	0,324	0,254	0,216	0,164	0,130	0,111
Diam. ext. (mm)	(13,5)	(12,3)	(11,3)	(9,8)	(8,2)	(6,5)	(5,5)	(4,2)	(3,3)	(2,8)
40 % DE REPLISSAGE Divisé	11	14	16	22	31	51	71	123	195	268
40 % DE REPLISSAGE Non divisé	22	26	31	43	60	98	135	235	373	512

Remarque : Utiliser une attache à tête plate de calibre 8 (tête de 7.9mm, 5/16" po.) ou une fixation équivalente pour assujettir le tube guide-fils et les raccords à la surface de montage.

Remarque : Mise à la terre: Utiliser l'emplacement de terre prévu ou poser le matériel qui convient: patte de mise à la terre, cosse circulaire à oeil ou écrou de blocage et manchon de terre.

CAPACIDAD DE PASO DE CABLES DE COMUNICACIÓN EN LAS CANALETAS DE LA SERIE 6000

TIPO	SIN BLINDAJE) PAR TRENZADO _i		TELEFÓNICO 24 AWG, N.º de pares				COAXIAL				TWINAXIAL	BLINDADO PAR TRENZADO			FIBRA ÓPTICO
	CAT 5	CAT 3	2	3	4	25	RG58/U	RG59/U	RG62/U	RG6/U	100 OHM	TIPO 1	TIPO 2	TIPO 3	Dos hilos (Dúplex) Multimodo, 62.5/125µm
D.E. Pulgadas	0.220	0.190	0.140	0.150	0.190	0.410	0.195	0.242	0.242	0.270	0.330	0.390	0.465	0.245	0.190
D.E. (mm)	(5.6)	(4.8)	(3.6)	(3.8)	(4.8)	(10.4)	(5.0)	(6.1)	(6.1)	(6.9)	(8.4)	(9.9)	(11.8)	(6.2)	(4.8)
PASO DEL 40% Dividido	80	107	198	172	107	23	102	66	66	53	35	25	17	64	107
PASO DEL 40% No dividido	161	217	399	348	217	46	206	133	133	107	71	51	36	139	217

* Cable amplificado de Categoría 6 (6a) para Ethernet de 10 gigabits – diámetro máx. permitido del cable según adendum N.º 11 ANSI TIA/EIA 568-B.2.

CAPACIDAD DE PASO DE CABLES DE ALIMENTACIÓN CON DISPOSITIVOS EN LAS CANALETAS DE LA SERIE 6000

TIPO AWG, THHN/THWN	2/0	1/0	1	2	4	6	8	10	12	14
D.E. Pulgadas	0.532	0.486	0.446	0.384	0.324	0.254	0.216	0.164	0.130	0.111
D.E. (mm)	(13.5)	(12.3)	(11.3)	(9.8)	(8.2)	(6.5)	(5.5)	(4.2)	(3.3)	(2.8)
PASO DEL 40% Dividido	14	17	20	27	38	62	86	149	237	325
PASO DEL 40% No dividido	28	34	40	54	76	125	173	300	475	652

CAPACIDAD DE PASO DE CABLES DE ALIMENTACIÓN SIN DISPOSITIVOS EN LAS CANALETAS DE LA SERIE 6000

TIPO AWG, THHN/THWN	2/0	1/0	1	2	4	6	8	10	12	14
D.E. Pulgadas	0.532	0.486	0.446	0.384	0.324	0.254	0.216	0.164	0.130	0.111
D.E. (mm)	(13.5)	(12.3)	(11.3)	(9.8)	(8.2)	(6.5)	(5.5)	(4.2)	(3.3)	(2.8)
PASO DEL 40% Dividido	11	14	16	22	31	51	71	123	195	268
PASO DEL 40% No dividido	22	26	31	43	60	98	135	235	373	512

NOTA: Utilice un tornillo de cabeza plana N.º 8 (5/16", tamaño de la cabeza de 7.9 mm) para montar la base en la superficie.

NOTA: Conexión a tierra: Utilice el punto de tierra cuando exista o instale una orejeta de tierra apropiada, un terminal de anillo o una contratuerca y conecte a tierra el casquillo.

660B

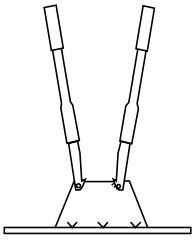

640C

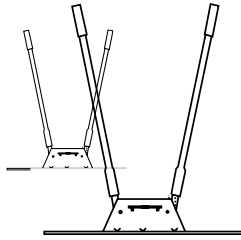

6000B-10

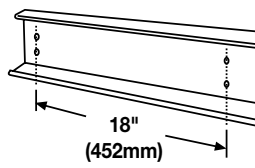

6000C

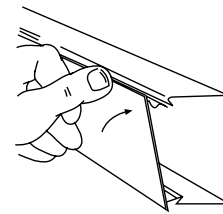

6000WC

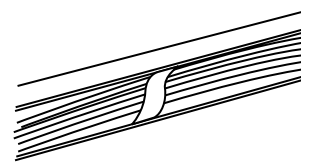

NOTE: 6000 Series Raceway must be secured to the mounting surface at intervals not exceeding 4' (1.2m).

Remarque : Le chemin de câbles de série 6000 doit être fixé à la surface de montage à des intervalles n'excédant pas 4 pi (1,2 m).

Nota: 6000 Series Raceway debe asegurarse a la superficie de montaje en intervalos que no superen los 4' (1.2 m).

4000WC

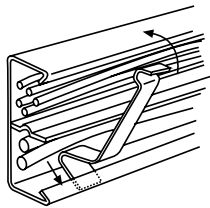

6001

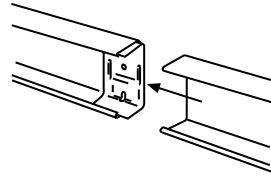

6001DA

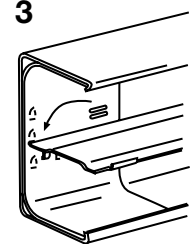
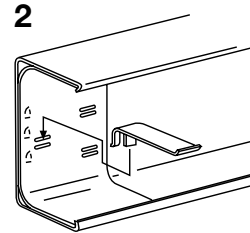
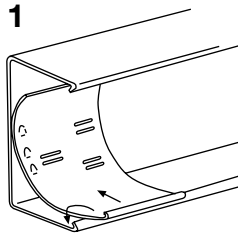

6006

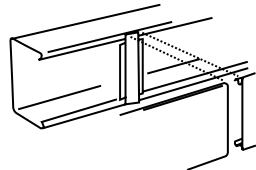

6007C-2/6007C-1

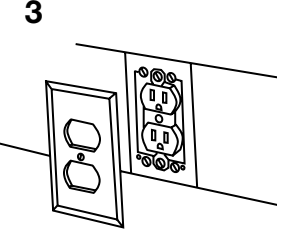
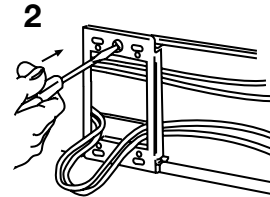
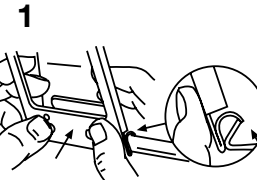

4

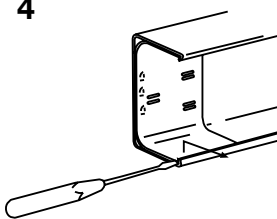

6008A

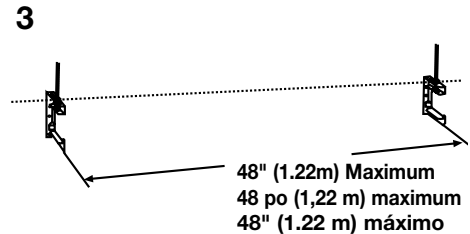
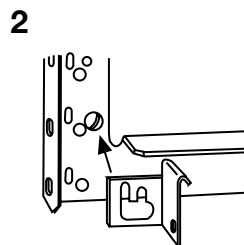
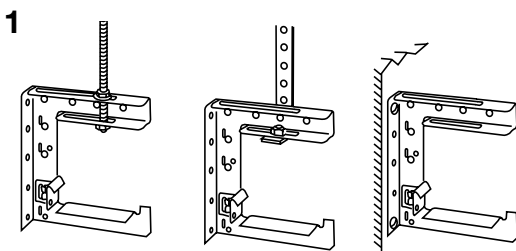

48" (1.22m) Maximum
48 po (1,22 m) maximum
48" (1.22 m) máximo

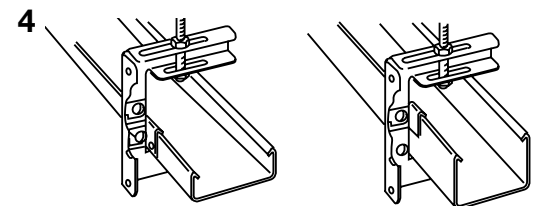

6010B

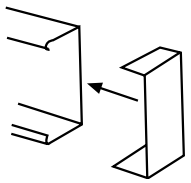

6011TX

1

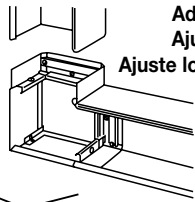

Adjust Screws if needed
Ajuster les vis au besoin
Ajuste los tornillos de ser necesario

1/2" (12.7mm)
1/2 po (12,7 mm)
1/2" (12.7 mm)

6001DA

2" (51mm)
2 po (51 mm)
2" (51 mm)

2

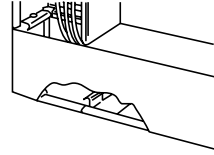

6011TX

1

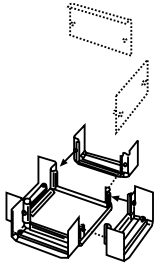

2

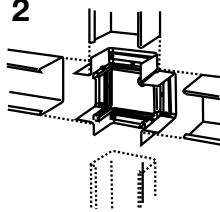

NOTE:

Wire Fill: 1/2 of values shown on page 2.

Remarque :

Remplissage de câbles : 1/2 des valeurs indiquées à la page 2.

Nota:

Relleno de cables: 1/2 de los valores se muestra en la página 2.

6012TX

1

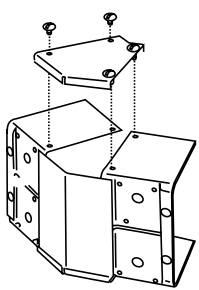

2

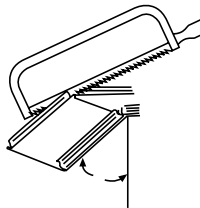

3

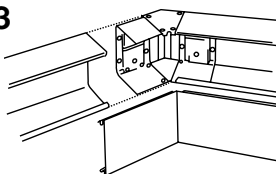

60012TX

1

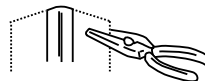

3

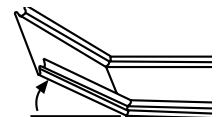
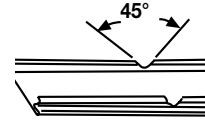

2

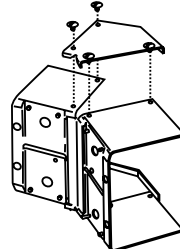

4

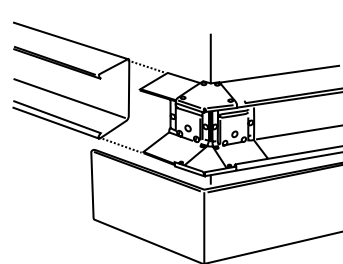

6014A

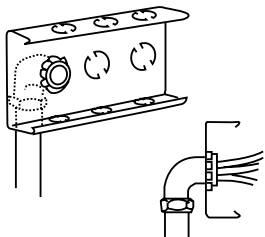

6017TX

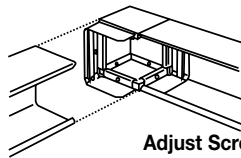

6017TX

1

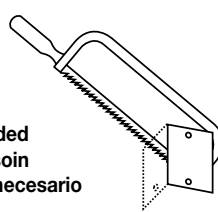

2

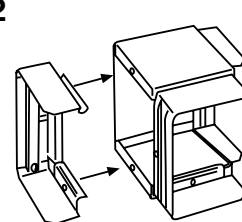

3

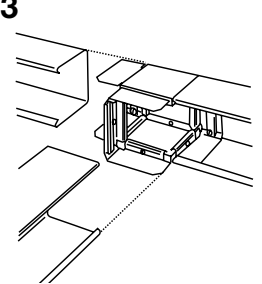

Adjust Screws if needed
Ajuster les vis au besoin
Ajuste los tornillos de ser necesario

1/2" (12.7mm)
1/2 po (12,7 mm)
1/2" (12.7 mm)

6001DA

2" (51mm)
2 po (51 mm)
2" (51 mm)

NOTE:

Wire Fill: 1/2 of values shown on page 2

Remarque :

Remplissage de câbles : 1/2 des valeurs indiquées à la page 2.

Nota:

Relleno de cables: 1/2 de los valores se muestra en la página 2.

6017TX

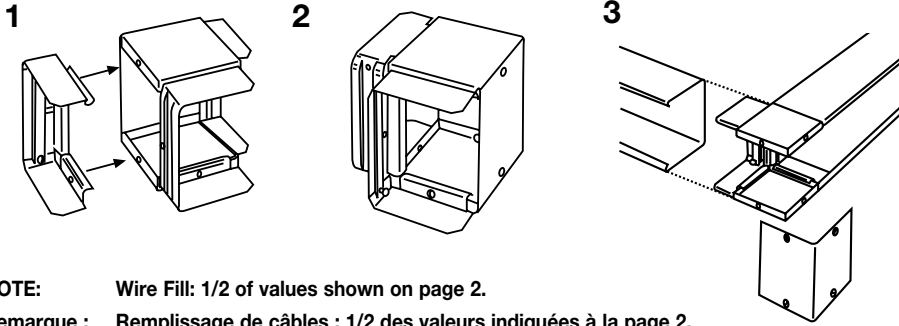

1" (25mm)
1 po (25mm)
1" (25mm)

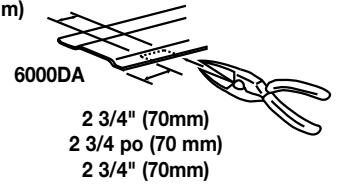

NOTE: Wire Fill: 1/2 of values shown on page 2.
Remarque : Remplissage de câbles : 1/2 des valeurs indiquées à la page 2.
Nota: Relleno de cables: 1/2 de los valores se muestra en la página 2.

6074/6074A

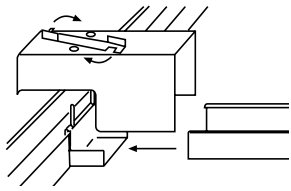

6086

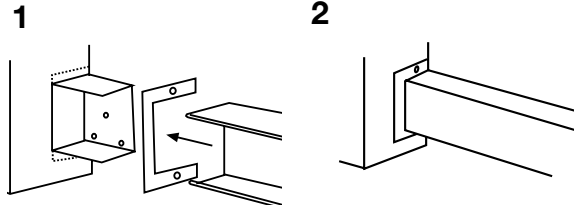

6046KD

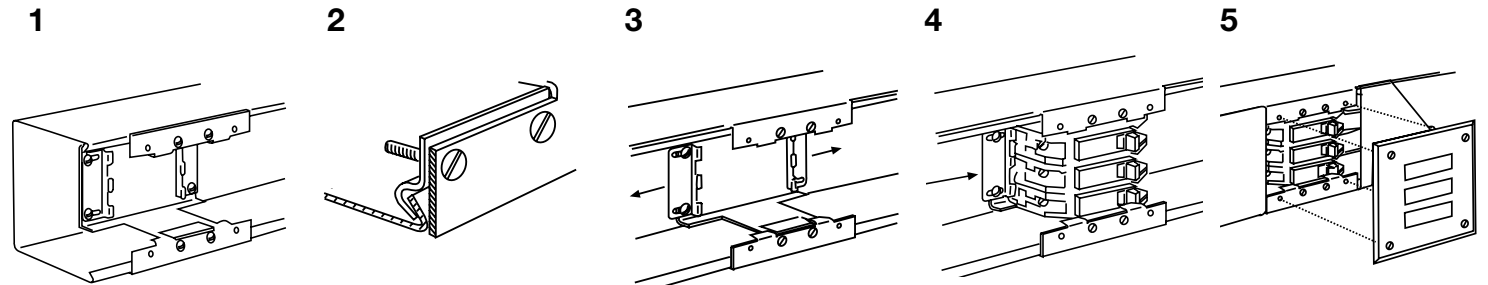

WIRE CAPACITY		Size AWG									
Type	2/0	1/0	#1	#2	#3	#4	#6	#8	#10	#12	#14
THHN, THWN	14	17	20	28	33	39	64	88	153	244	334

Capacité / câble		Calibre AWG									
Type	2/0	1/0	n° 1	n° 2	n° 3	n° 4	n° 6	n° 8	n° 10	n° 12	n° 14
THHN, THWN	14	17	20	28	33	39	64	88	153	244	334

Capacidad del cable		Tamaño en AWG									
Tipo	2/0	1/0	#1	#2	#3	#4	#6	#8	#10	#12	#14
THHN, THWN	14	17	20	28	33	39	64	88	153	244	334

No: 41401R3 04 18



860.233.6251
1.877.BY.LEGRAND
www.legrand.us
www.legrand.ca

© Copyright 2018 Legrand All Rights Reserved.
© Copyright 2018 Tous droits réservés Legrand.
© Copyright 2018 Legrand Todos los derechos reservados.

