



WIREMOLD®

3000® Series Raceway

Chemin de câbles de série 3000®

Conducto eléctrico serie 3000®

No: 41402R1 0517

Installation Instructions • Notice d'Installation • Instrucciones de Instalación

Catalog Number(s) • Numéro(s) de catalogue • Número(s) de catálogo: 630B, 630C, 3000B, 3000C, 3000WC, 3001, 3001A, 3007C, 3008C, 3010AE, 3010C, 3011E, 3014C, 3015E, 3017NE, 3017TCE, 3018AE, 3046BE, 3046H2, 3082, 3086A, 3089E, 3046KD, 30146KTSQ, 3046QUO

Country of Origin • Pays d'origine • País de origen: Made in USA • Fabriqué aux USA • Hecho en USA

**IMPORTANT:**

**Please read all instructions before beginning installation**

Legrand electrical systems conform to and should be properly grounded in compliance with requirements of the current National Electrical Code or codes administered by local authorities.

All electrical products may present a possible shock or fire hazard if improperly installed or used. Legrand electrical products may bear the mark of a Nationally Recognized Testing Laboratory and should be installed in conformance with current local and/or the National Electrical Code.

**NOTE:**

All unblocked openings intended for wiring devices, fittings or accessories must be closed off by appropriate wiring devices, fittings or accessories prior to initial circuit energization.

**IMPORTANT :**

**Veillez lire l'ensemble des instructions avant de commencer l'installation.**

Les systèmes électriques Legrand sont conformes au Code National de l'électricité (National Electrical Code) ou aux codes locaux en vigueur et doivent être mis à la terre conformément à ces codes.

Tous les produits électriques peuvent présenter un risque d'électrocution ou d'incendie s'ils ne sont pas installés ou utilisés correctement. Les produits électriques Legrand peuvent porter la marque d'un laboratoire reconnu et doivent être installés conformément au Code national de l'électricité et/ou aux codes locaux en vigueur.

**Remarque :**

Toutes les ouvertures non bloquées destinées aux câbles, aux raccords ou aux accessoires doivent être fermées par des dispositifs de câblage, des raccords ou des accessoires appropriés avant l'activation du circuit initial.

**IMPORTANTE:**

**Lea todas las instrucciones antes de comenzar la instalación.**

Los sistemas eléctricos Legrand cumplen con los requisitos del Código Eléctrico Nacional (National Electrical Code, NEC) actual o con los códigos impuestos por las autoridades locales y deben conectarse a tierra consecuentemente.

Todos los productos eléctricos pueden presentar un riesgo de descarga o incendio si se los instala o utiliza incorrectamente. Los productos eléctricos Legrand pueden llevar la marca de un laboratorio de pruebas reconocido a nivel nacional y se deben instalar conforme al código local en vigencia o al Código Eléctrico Nacional.

**Nota:**

Todas las aperturas desbloqueadas de los dispositivos de cableado, equipamiento o accesorios deben cerrarse con los dispositivos de cableado, equipamiento o accesorios adecuados antes del suministro inicial de energía al circuito.

**3000 SERIES RACEWAY WIRE FILL CAPACITIES FOR COMMUNICATIONS**

	CABLE/WIRE SIZE	O.D. (APPROX. DIA.)		40% FILL
		Inches	(mm)	
UNSHIELDED	4-pair, 24 AWG, Cat 3	0.190	(4.8)	52
TWISTED PAIR	4-pair, 24 AWG, Cat 5e	0.210	(5.3)	42
	4-pair, 24 AWG, Cat 6	0.250	(6.3)	30
	4-pair, 24 AWG, Cat 6a*	0.354	(9.0)	15
	25-pair, 24 AWG	0.410	(10.4)	11
COAXIAL	RG6/U	0.270	(6.9)	25
FIBER	ZipCord	0.118 x 0.236	(3 x 6)	53
	Round 4 Strand Fiber	0.187	(4.8)	53
	Round 6 Strand Fiber	0.256	(6.5)	28

\* Category 6 augmented (6a) cable for 10 gigabit ethernet – max allowed cable diameter per addenda No. 11 ANSI TIA/EIA 568-B.2.

**3000 SERIES RACEWAY WIRE FILL CAPACITIES FOR POWER**

WIRE SIZE THHN/THWN	O.D.		WITHOUT DEVICES	NUMBER OF CONDUCTORS (40% FILL)		
	Inches	(mm)		WITH DUPLEX RECT. DEVICES 1.59in. <sup>2</sup> (1025mm <sup>2</sup> )	WITH SURGE/ GFCI DEVICES 2.30in. <sup>2</sup> (1485mm <sup>2</sup> )	LARGE SINGLE RECEPTACLES 3.00in. <sup>2</sup> (1935mm <sup>2</sup> )
14 AWG	0.111	(2.8)	152	70	40	28
12 AWG	0.130	(3.3)	111	51	29	21
10 AWG	0.164	(4.2)	70	32	18	13
8 AWG	0.216	(5.5)	40	18	10	7
6 AWG	0.254	(6.5)	29	13	7	5

**NOTE:** Use No. 8 (5/16", 7.9mm head size) flat head fastener or equivalent to mount base to surface.

**NOTE:** Grounding: Use ground location when provided or install a suitable ground lug, ring terminal or locknut and ground bushing.

## CAPACITÉS DE REMPLISSAGE DU CHEMIN DE CÂBLES DE SÉRIE 3000 POUR LES CÂBLES DE COMMUNICATION

CALIBRE DES CÂBLES/FILS	D.E. (DIAMÈTRE APPROX.)		40 % REPL.
	Pouces	(mm)	
NON BLINDÉ 4 paires, 24 AWG, Cat. 3	0,190	(4,8)	52
PAIRE TORSADÉE 4 paires, 24 AWG, Cat. 5e	0,210	(5,3)	42
4 paires, 24 AWG, Cat. 6	0,250	(6,3)	30
4 paires, 24 AWG, Cat. 6a*	0,354	(9,0)	15
25 paires, 24 AWG	0,410	(10,4)	11
COAXIAL RG6/U	0,270	(6,9)	25
FIBRE Zipcord	0,118 x 0,236	(3 x 6)	53
Fibre ronde à 4 brins	0,187	(4,8)	53
Fibre ronde à 6 brins	0,256	(6,5)	28

\* Câble de catégorie 6 améliorée (6a) pour 10 gigabit Ethernet – diamètre maxi du câble autorisé selon l'addenda n° 11 ANSI TIA/EIA 568-B.2.

## CAPACITÉS DE REMPLISSAGE DU CHEMIN DE CÂBLES DE SÉRIE 3000 POUR LES CÂBLES D'ALIMENTATION

CALIBRE DES FILS THHN/THWN	D.E. Pouces	(mm)	NOMBRE DE CONDUCTEURS (40 % DE REMPLISSAGE)			
			SANS DISPOSITIFS	AVEC DUPLEX DISPOSITIFS DE PRISE 1,59 po <sup>2</sup> (1 025 mm <sup>2</sup> )	AVEC SURTENSION/ DISPOSITIFS DDFT 2,30 po <sup>2</sup> (1 485 mm <sup>2</sup> )	GRAND SIMPLE PRISES 3,00 po <sup>2</sup> (1 935 mm <sup>2</sup> )
14 AWG	0,111	(2,8)	152	70	40	28
12 AWG	0,130	(3,3)	111	51	29	21
10 AWG	0,164	(4,2)	70	32	18	13
8 AWG	0,216	(5,5)	40	18	10	7
6 AWG	0,254	(6,5)	29	13	7	5

Remarque : Utiliser une attache à tête plate de calibre 8 (tête de 7,9 mm, 5/16 po) ou une fixation équivalente pour assujettir le tube guide-fils et les raccords à la surface de montage.

Remarque : Mise à la terre: Utiliser l'emplacement de terre prévu ou poser le matériel qui convient: patte de mise à la terre, cosse circulaire à oeil ou écrou de blocage et manchon de terre.

## CAPACIDADES DE CABLEADO PARA LAS COMUNICACIONES DE 3000 SERIES RACEWAY

	TAMAÑO DEL CABLE	D.E. (DIÁ. APROX.)		40 % RELLENO
		Pulgadas	(mm)	
PAR TRENZADO	4 pares, 24 AWG, Cat. 3	0.190	(4.8)	52
SIN BLINDAR	4 pares, 24 AWG, Cat. 5e	0.210	(5.3)	42
	4 pares, 24 AWG, Cat. 6	0.250	(6.3)	30
	4 pares, 24 AWG, Cat. 6a*	0.354	(9.0)	15
	25 pares, 24 AWG	0.410	(10.4)	11
	COAXIAL	RG6/U	0.270	(6.9)
FIBRA	ZipCord	0.118 x 0.236	(3 x 6)	53
	Fibra entretrejida de 4 hebras	0.187	(4.8)	53
	Fibra entretrejida de 6 hebras	0.256	(6.5)	28

\* Cable de Categoría 6 (6a) aumentada para la Ethernet de 10 gigabit; diámetro máximo de cable permitido de acuerdo con el apéndice n.º 11 ANSI TIA/EIA 568-B.2.

## CAPACIDADES DE CABLEADO PARA LA ALIMENTACIÓN DE 3000 SERIES RACEWAY

TAMAÑO DEL CABLE THHN/THWN	Pulgadas	D.E. (mm)	NÚMERO DE CONDUCTORES (40 % REL.)			
			SIN DISPOSITIVOS	CON DISP. DOBLES. RECT. 1.59 in <sup>2</sup> (1025 mm <sup>2</sup> )	CON DISP. PICO/GFCI 2.30 in <sup>2</sup> (1485 mm <sup>2</sup> )	RECEPTÁCULOS SIMPLES GRANDES 3.00 in <sup>2</sup> (1935 mm <sup>2</sup> )
14 AWG	0.111	(2.8)	152	70	40	28
12 AWG	0.130	(3.3)	111	51	29	21
10 AWG	0.164	(4.2)	70	32	18	13
8 AWG	0.216	(5.5)	40	18	10	7
6 AWG	0.254	(6.5)	29	13	7	5

**Nota:** Use un sujetador de cabeza plana No. 8 (tamaño de cabeza: 7.9mm, 5/16" de pulgada) o su equivalente para unir la canalita y los accesorios a la superficie de montaje.

**Nota:** Conexión a tierra: Use un localizador de tierra cuando se proporcione o instale una orejeta de tierra, anillo terminal o contratuerca y cojinetes de tierra apropiados.

630B

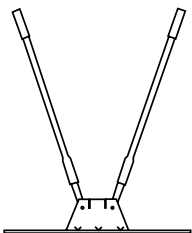

630C

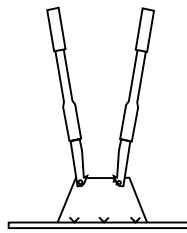

3000B

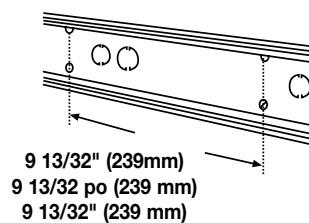

3000C

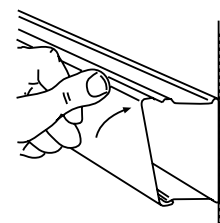

3000WC

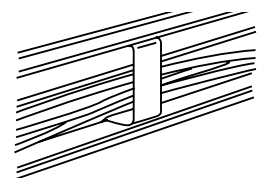

**NOTE:** 3000 Series Raceway must be secured to the mounting surface at intervals not exceeding 4' (1.2m).

**Remarque :** Le chemin de câbles de série 3000 doit être fixé à la surface de montage à des intervalles n'excédant pas 4 pi (1,2 m).

**Nota:** 3000 Series Raceway debe asegurarse a la superficie de montaje en intervalos que no superen los 4' (1.2 m).

**Precut Covers**  
**Couvercles prédécoupés**  
**Tapas precortadas**

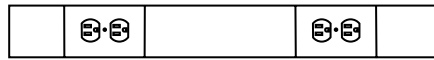

3000C075 = 12" (305mm)  
 3000C195 = 24" (610mm)  
 3000C075 = 12 po (305 mm)  
 3000C195 = 24 po (610 mm)  
 3000C075 = 12" (305 mm)  
 3000C195 = 24" (610 mm)

**3001**

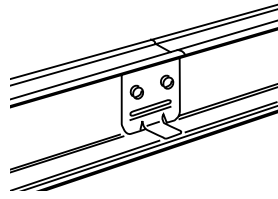

**3001A**

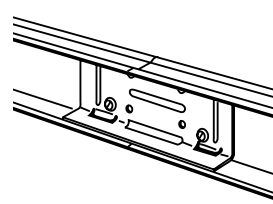

**3007C**

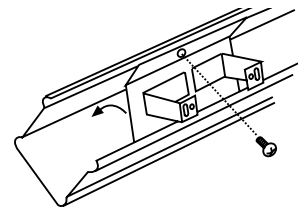

**3008C**

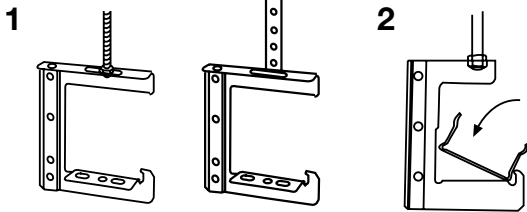

**NOTE:** Hanger brackets must be installed at maximum 48" (1.2m) intervals.

**Remarque :** Les supports de suspension doivent être installés à des intervalles de 48 po (1,2 m) au maximum.

**Nota:** Los soportes de suspensión deben instalarse en intervalos de 48" (1.2 m) como máximo.

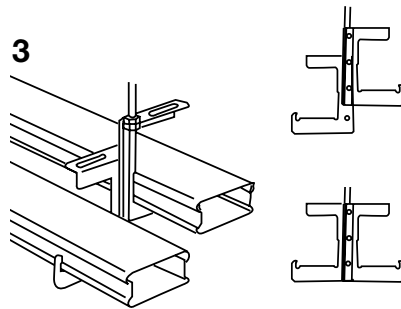

**3010AE**

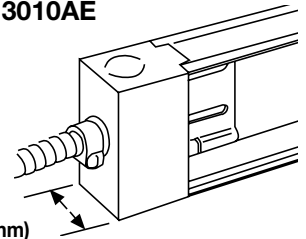

1 1/2" (38mm)  
 1 1/2 po (38 mm)  
 1 1/2" (38mm)

**3010C**

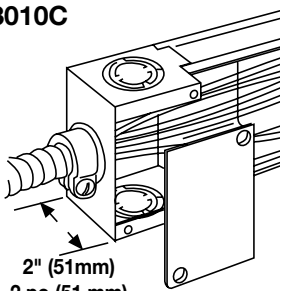

2" (51mm)  
 2 po (51 mm)  
 2" (51 mm)

**3011E**

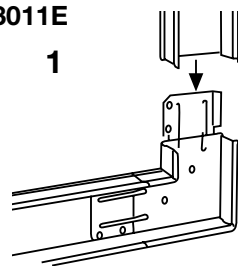

**2**

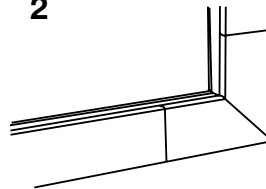

**3014C**

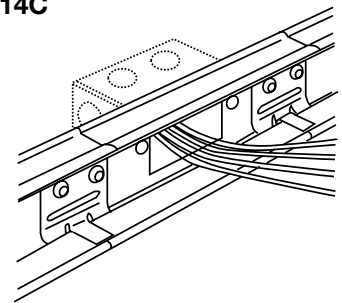

3015E

1

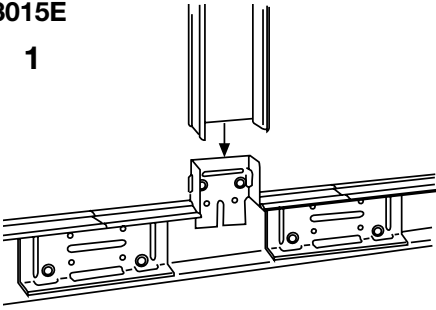

3017NE

1

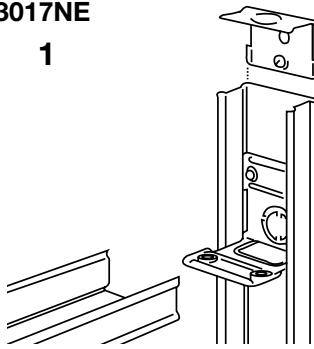

3017TCE

1

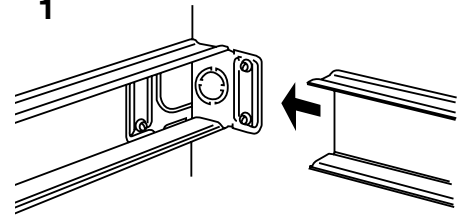

2

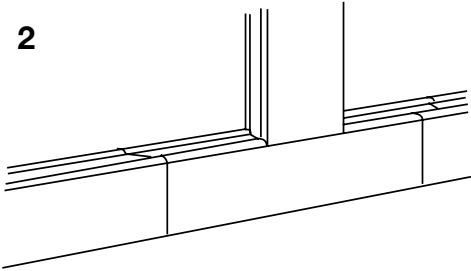

2

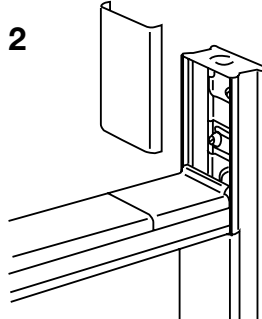

2

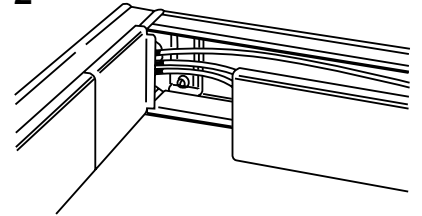

Wire Capacity as a through fitting					
Type	#6 AWG	#8 AWG	#10 AWG	#12 AWG	#14 AWG
THHN, THWN	13	18	24	55	75

Câbles de capacité de passage dans un chemin de câbles					
Type	n° 6 AWG	n° 8 AWG	n° 10 AWG	n° 12 AWG	n° 14 AWG
THHN, THWN	13	18	24	55	75

Capacidad del cable como accesorio de paso					
Tipo	#6 AWG	#8 AWG	#10 AWG	#12 AWG	#14 AWG
THHN, THWN	13	18	24	55	75

3018AE

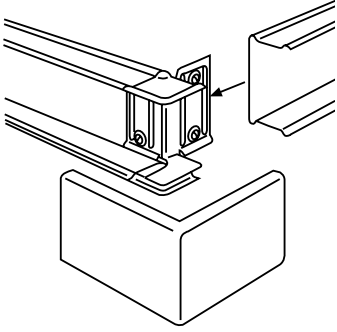

3046BE

1

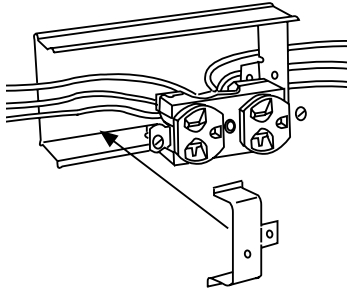

2

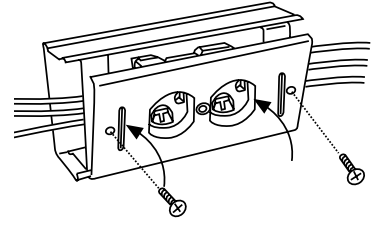

3046H2

1

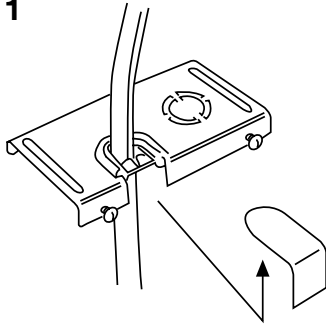

2

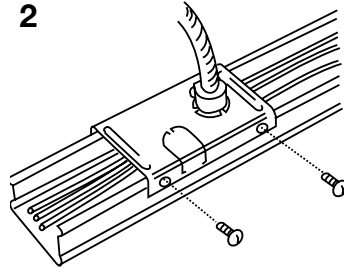

3082

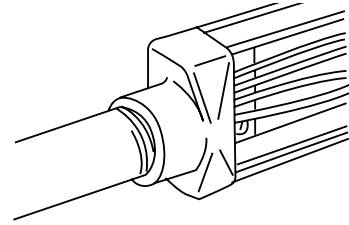

3086A

1

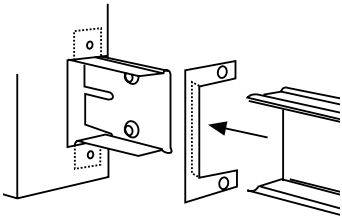

2

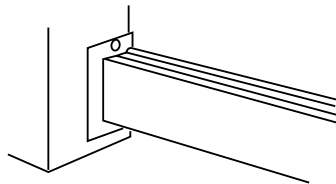

3089E

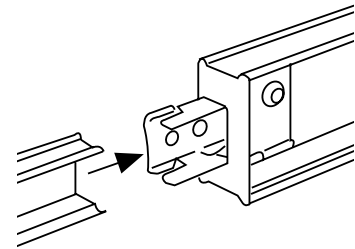

3046KD

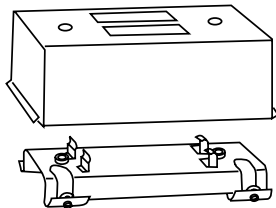

3046KTSQ

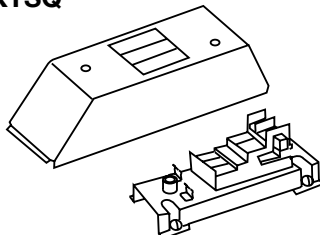

3046QUO

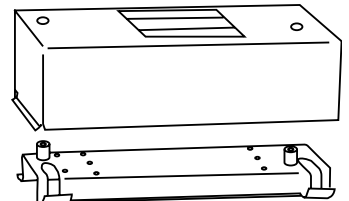

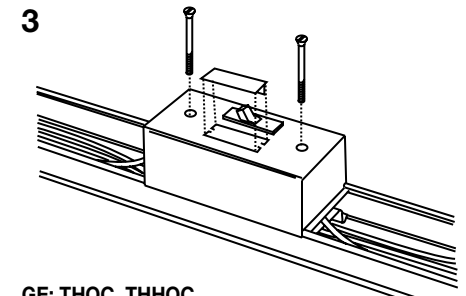
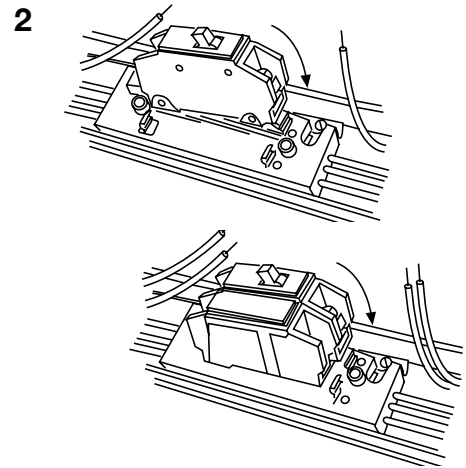
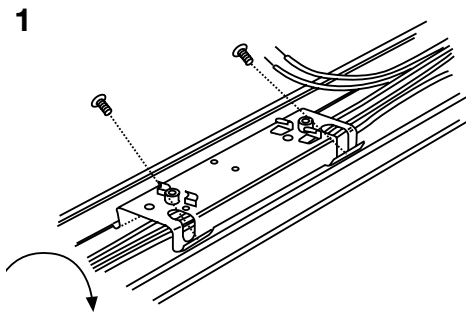

GE: THQC, THHC.  
Westinghouse: QuicklagC, QCH

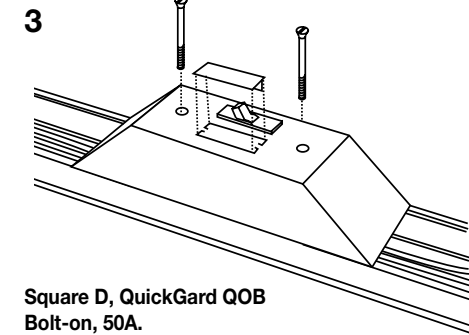
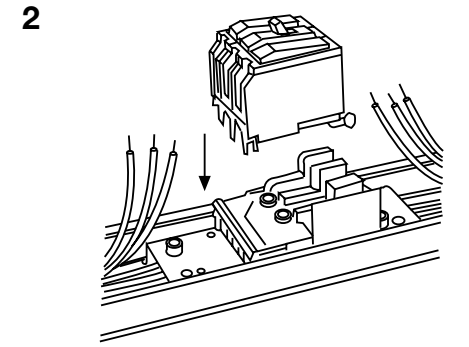
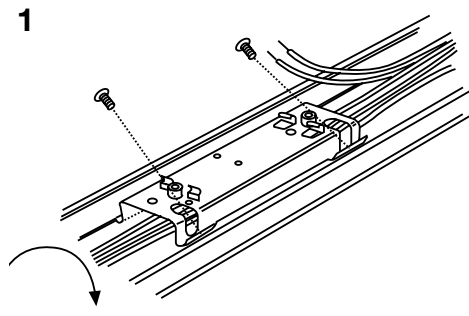

Square D, QuickGard QOB  
Bolt-on, 50A.

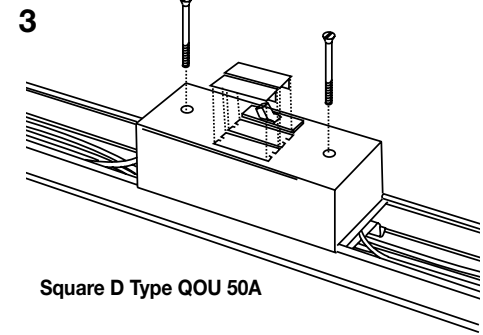
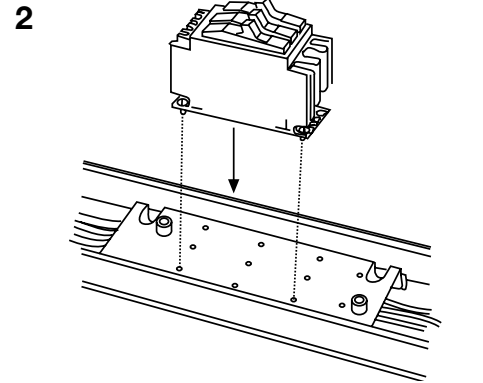
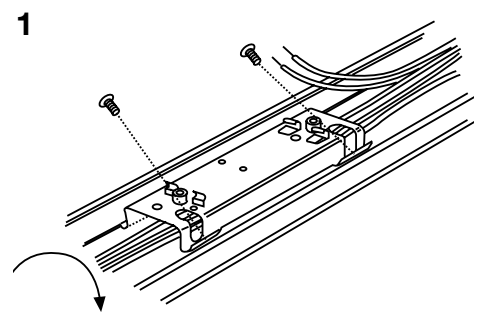

Square D Type QOU 50A

**NOTE:** Remove knockouts prior to installation of circuit breakers.

**Remarque :** Retirer les alvéoles défonçables avant l'installation des disjoncteurs.

**Nota:** .Retire los agujeros ciegos antes de instalar los disyuntores.

**Wire Capacity as a through fitting**

Type	#6 AWG	#8 AWG	#10 AWG	#12 AWG	#14 AWG
THHN, THWN	6	8	10	18	26

**Câbles de capacité de passage dans un chemin de câbles**

Type	n° 6 AWG	n° 8 AWG	n° 10 AWG	n° 12 AWG	n° 14 AWG
THHN, THWN	6	8	10	18	26

**Capacidad del cable como accesorio de paso**

Tipo	#6 AWG	#8 AWG	#10 AWG	#12 AWG	#14 AWG
THHN, THWN	6	8	10	18	26

No: 41402R1 0517



860.233.6251  
1.877.BY.LEGRAND  
www.legrand.us  
www.legrand.ca

© Copyright 2017 Legrand All Rights Reserved.  
© Copyright 2017 Tous droits réservés Legrand.  
© Copyright 2017 Legrand Todos los derechos reservados.

