

INTEGRATED FIXTURE SENSOR & CONTROLLER

LMFS-601

Built-in IPv6 Mesh and Bluetooth® low energy technology provides robust signal strength and reliable communication

Low profile design to maintain the fixture aesthetic

Custom programming using DLM Configuration App



Carrier sleeve and snap-in sensor make for quick and easy installation into fixture housing

Completely scalable fixture level lighting control (LLLC)



DESCRIPTION

The LMFS-601 is a wireless fixture sensor and controller that is compatible with all Wattstopper wireless DLM devices. The LMFS-601 includes a passive infrared (PIR) occupancy sensor and a closed loop photo sensor. It measures both motion and daylight contribution in order to automatically switch or dim lighting. The LMFS-601 is compatible with DALI drivers and standard 0-10V drivers for dimming and ON/OFF control signaling. It also provides the ability to communicate to other DLM enabled fixtures in the space without any additional equipment.

OPERATION

The fixture sensor is designed to be integrated directly into a fixture at the fixture manufacturer. The fixture sensor has a unique sequence of operation, allowing fixture manufacturers to quickly perform end of line testing and ensure successful installation.

The LMFS-601 can be programmed to operate as independent fixture sensors & controllers or create stand-alone networks incorporating other DLM Wireless devices. The fixture sensor operates on 12-20VDC from a DALI bus, available via DALI Driver with Integrated Self Powered DALI Link or a Wattstopper Fixture Interface (LMFI-111).

Startup is accomplished using the DLM Configuration App for iOS® or Android®. Users can discover the LMFS-601 in the DLM Config app via occupancy detection. After Discovery, users can walk through on-screen prompts to configure the LMFS-601.

SIMPLIFIED SETUP AND CONFIGURATION

Each LMFS-601 includes Bluetooth low energy technology to communicate with the DLM Configuration App on the installer's mobile device. Some custom configuration functions include:

PIR Sensitivity: The digital Passive Infrared sensors sensitivity level is adjustable and by default is set at 100% sensitivity.

Daylight Harvesting and Daylight Zones: By default, the daylight functionality within the LMFS-601 is disabled. To enable and set daylight sensing parameters, users must calibrate the daylight sensor using the configuration app. The configuration app may be used to adjust setpoints and other daylighting parameters, including hold off functionality and the ability turn the lights off should there be enough light in the target area. Users can calibrate the daylight sensor for each daylight zone they want created. Daylight zones can include multiple LMFS-601's and other load devices.

Grouping: In addition to simple room creation, custom groups can be created within the App to meet advanced energy code sequence of operations.

Partial ON/OFF and Time Delays: Default time delays are set at 20 minutes, but can be configured at the user's discretion. Partial ON/OFF levels can be set in conjunction with Grouping to meet code compliance while maintaining aesthetic sequence of operations in a space.

Trim Levels: High Trim level is set at 100% by default to be code compliant. Trim levels can be programmed using the configuration app.

APPLICATIONS

LMFS-601 fixture sensors are designed to be scalable and enable flexibility in a space. They can be utilized in stand alone, room-based, and multi-room applications. The fixture sensors are ideal for areas where space reconfiguration is common, such as open offices, classrooms, and open break areas. The LMFS-601 is ideal for integration into linear fixtures, panels, and troffer fixtures.

PROJECT	LOCATION/ TYPE

FEATURES

- Component of the wireless Digital Lighting Management control system
- Streamlined startup and commissioning using the DLM Configuration App
- Enables a fixture to be independently capable of occupancy sensing, daylight sensing to maintain a desired light level, and configurability including dimming set-points, timeouts, fade rates, sensor sensitivity, and wireless zoning.
- Meet advanced energy codes calling for fixture level lighting control (LLLC)
- Built-in IPv6 Mesh/Bluetooth low energy technology provides robust signal strength and reliable communication
- Firmware can easily be updated over the air using the DLM Configuration App (which communicates via Bluetooth low energy technology).
- Easy installation and end of line testing to save fixture manufacturers time and cost
- Supports various emergency power configurations

SPECIFICATIONS

- Input Voltage: 12-20V
- Power Consumption from DALI Bus: 16mA
- Power Supply: DALI Driver with Integrated Self Powered DALI Link or A Wattstopper Fixture Interface (LMFI-111)
- Wiring: 18-20 AWG
- Terminal Connection: DA+, DA-
- Adjustable Time Delay: 5-30 Min
- High Trim: 1-100%
- Low Trim: 1-99%
- Sensor Mode: Auto ON or Manual ON
- Daylight Harvesting: Disable/Enable
- Daylight Sensor: Closed Loop
- PIR Sensitivity: 10-100%
- Partial ON: 1-100%
- Partial OFF: 1-100%
- Dimming: 0-10V Dimming (Dimming performance dependent on LED Driver)
- L8 Lens for Mounting 8' to 12'
- Stand-alone network parameters (no LMBR-650): up to 35 loads, up to 35 communicating devices
- Wireless Standards supported:
 - IPv6 Mesh (6LoWPAN / 802.15.4 / 2.4GHz), range up to 100 ft.
 - Bluetooth low energy (802.15.4 / 2.4GHz), range up to 30 ft. Operating Temperature: 32-149°F (0-65°C)
- Relative Humidity: 0 to 90% (non-condensing)
- Enclosure impact rating: IK05
- Indoor Use Only
- IP20 rated
- UL2043 Plenum Approved – Suitable for Use in Air Handling Spaces
- UL/CUL listed under UL60730: Type 1, Independently Mounted, Sensor Pollution Degree 2, Impulse Voltage Rated – 330V
- Five year warranty

DIMENSIONS

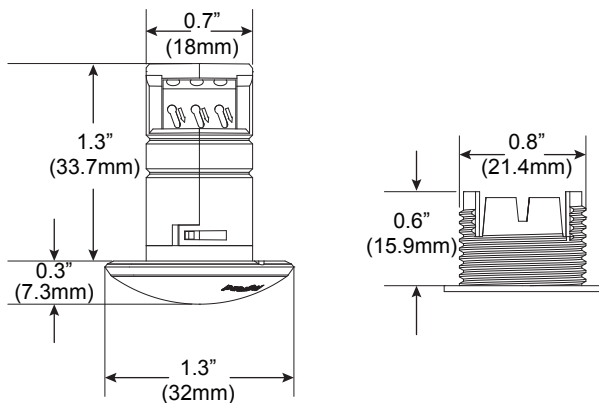

COMPONENTS

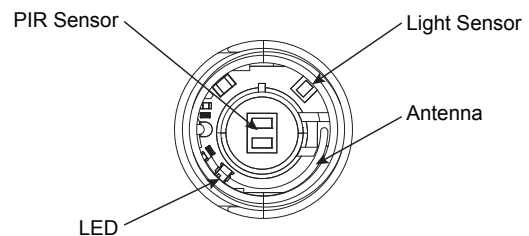

WIRING

LMFS-601 with 0-10V LED Driver and LMFI-111 Fixture Interface

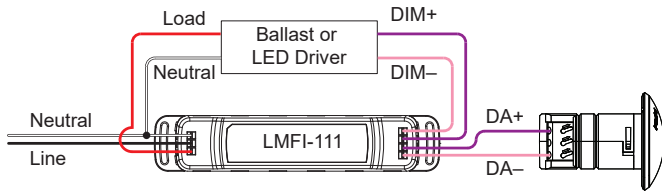

LMFS-601 with multiple 0-10V LED Drivers and LMFI-111 Fixture Interface

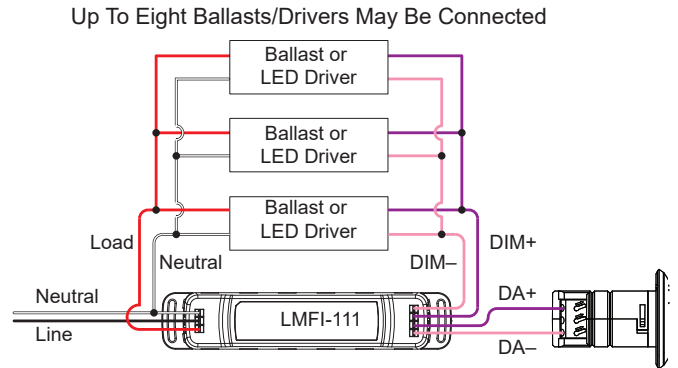

NOTE: Do not mix drivers from different manufacturers in the same fixture.

LMFS-601 with DALI Driver

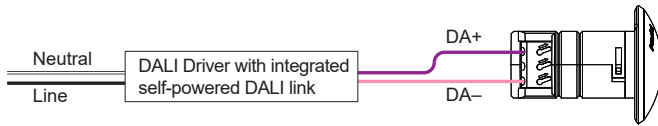

CONNECTION TO A WIRELESS DLM SYSTEM

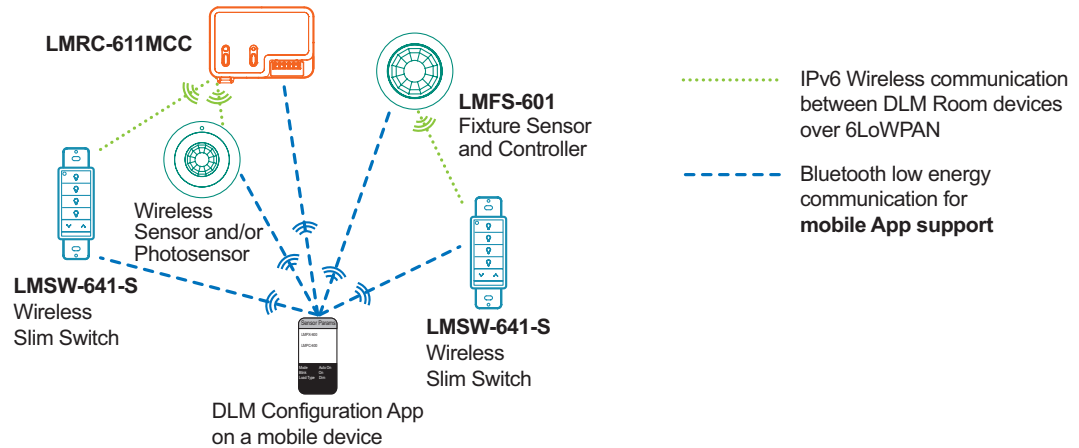

(Note that a single LMSW6xx-S can control both wireless room controllers and the LMFS-601.)

COVERAGE

The LMFS-601 provides a 360° coverage pattern. The coverage shown represents maximum coverage for walking motion at a mounting height of 8 feet. The lens is designed for mounting heights ranging 8'-12' and covers up to 300 sq/ft of space.

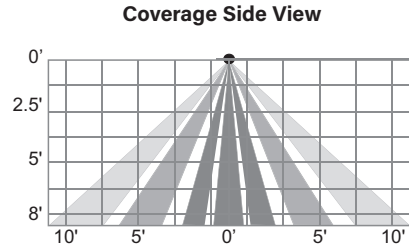
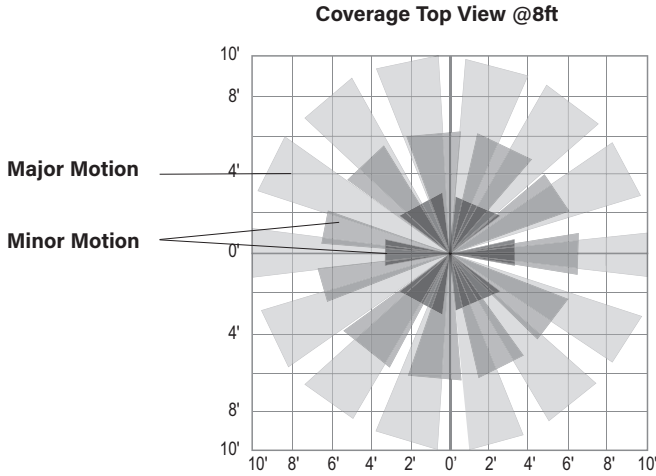

Sensor Placement

- Mount sensor at least 6' away from air supply.
- Avoid obstacles that block sensor's line-of-sight.

ORDERING INFORMATION

Catalog #	Description	Voltage	Total Rating
<input type="checkbox"/> LMFS-601	Integrated Fixture Sensor and Controller, Occupancy, Daylight Harvesting, and IPv6/Bluetooth	12-20VDC	16mA current consumption from DALI bus
<input type="checkbox"/> LMFI-111	Fixture Interface, 120-277V, 1-10V DIMMING, Power to LMFS-601	120/277VAC	3A @ 120-277V

The Bluetooth® word mark and logos are registered trademarks owned by the Bluetooth SIG, Inc. and any use of such marks by Wattstopper is under license.

Google Play and the Google Play logo are trademarks of Google Inc.

The Apple logo, iPhone, iPod touch, and iTunes are trademarks of Apple Inc., registered in the U.S. and other countries.