

STEP 1:
STRIP 1-1/4" OF CABLE JACKET
OFF STATION CABLES. TRIM
SPLINE FLUSH.

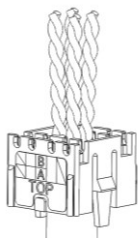

STEP 2:
INSERT THE CABLE WIRES
INTO THE LACING CAP HOLES
ACCORDING TO RELEVANT
COLOR CODING

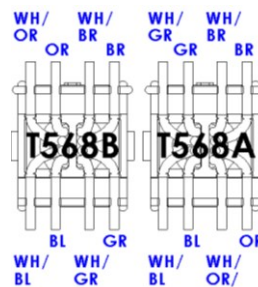
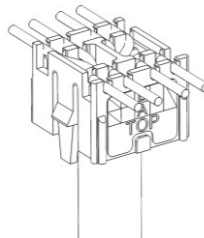

STEP 3:
SEAT THE WIRES INTO THE
APPROPRIATE SLOTS

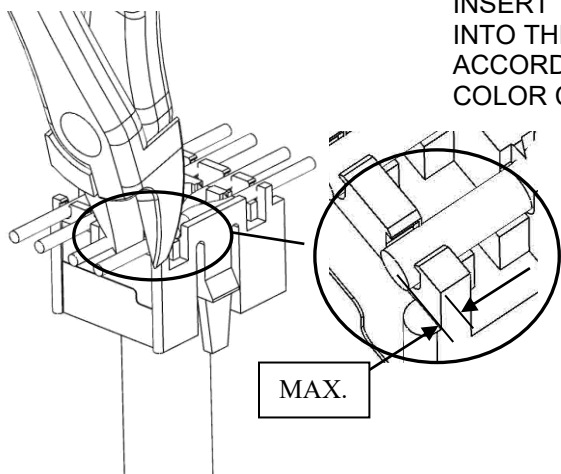

NOTE UPPER
GROOVES IN
JACK HOUSING

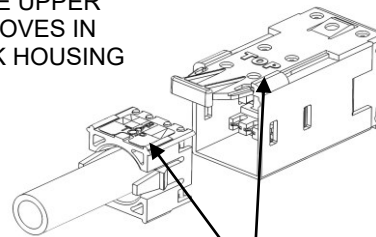
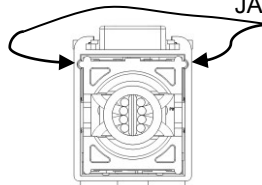

ALIGN "TOP" ON BOTH SLIDE LOCK
AND LACING CAP LABEL

STEP 4:
TRIM EXCESS WIRES FLUSH WITH EDGE
OF LACING CAP. (MAX. OF .020" FROM
THE EDGE OF THE LACING CAP.)

STEP 5:
ALIGN LACING CAP TO THE JACK BODY
AND SEAT BOTH PARTS TOGETHER.
MAKE SURE TABS ON LACING CAP ALIGN
WITH THE HOUSING GROOVES.

CLICK

SLIDE LOCK

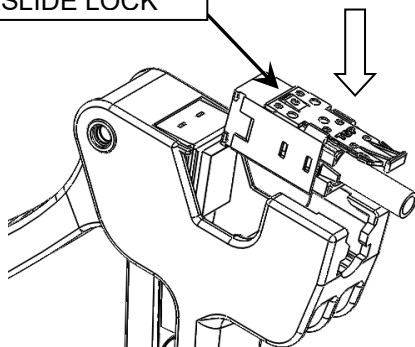

STEP 6:
INSERT ASSEMBLED JACK
INTO TERMINATION TOOL
WITH SLIDE LOCK ON JACK
AS SHOWN.

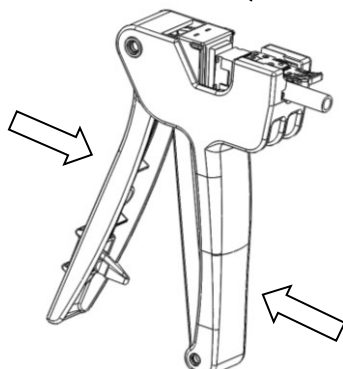

STEP 7:
SQUEEZE HANDLES TOGETHER.
AN AUDIBLE CLICK SHOULD BE
HEARD WHEN THE JACK IS
TERMINATED.

WIRING CHART

COLOR CODE LABEL	RJ45 8P8C T568A WIRING	RJ45 8P8C T568B WIRING
WHITE/BLUE	5	5
BLUE	4	4
WHITE/ORANGE	3	1
ORANGE	6	2
WHITE/GREEN	1	3
GREEN	2	6
WHITE/BROWN	7	7
BROWN	8	8

SUPPLIED TERMINATION TOOL OPERATION

STEP 1A:
LACE, TRIM CONDUCTORS INTO LACING CAP AND INSERT LACING CAP ASSEMBLY INTO JACK BODY PER STEPS 1 THRU STEP 5 OF PAGE 1 OF THIS DOCUMENT.

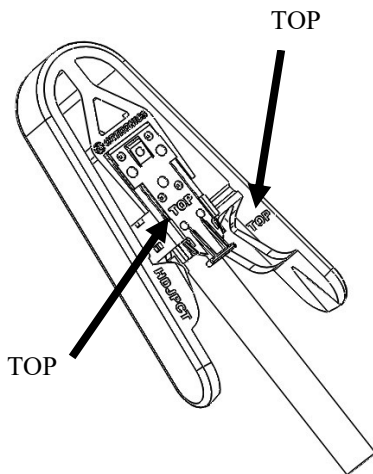

STEP 2A:
HOLD THE TOOL IN ONE HAND WHILE HOLDING THE CABLE/JACK IN THE OTHER. INSERT THE CABLED JACK INTO THE TOOL YOKE AS SHOWN. NOTE THE 'TOP' OF THE JACK MATCHES THE 'TOP' MARKED ON THE TOOL.

NOTE; THE HD JACK IS FULLY INSERTED

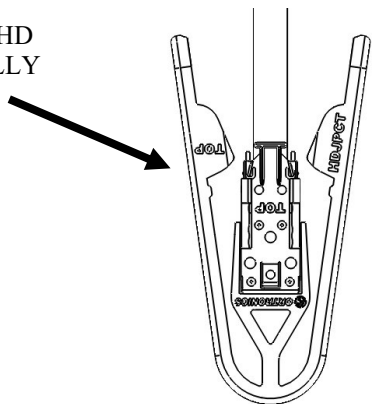

NOTE; THE HD JACK IS FULLY INSERTED AND CENTERED IN TOOL

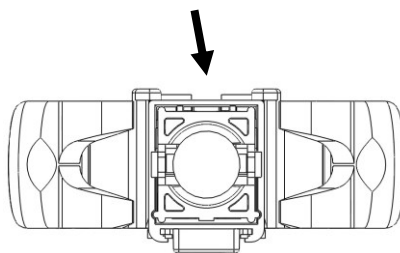

STEP 3A:
SQUEEZE THE TOOL TOGETHER UNTIL YOU HEAR THE LACING CAP 'CLICK' INTO PLACE. BE SURE BOTH SIDE LATCHES CLICK INTO PLACE. GENTLY TUG ON THE CABLE TO ENSURE PROPER TERMINATION.

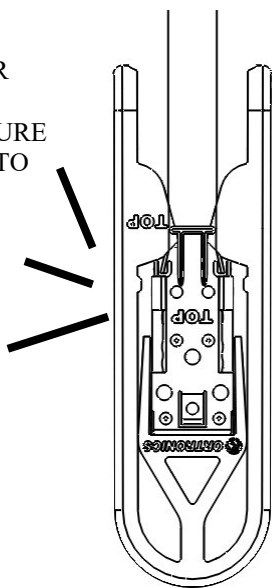

CLICK

DISASSEMBLY INSTRUCTIONS

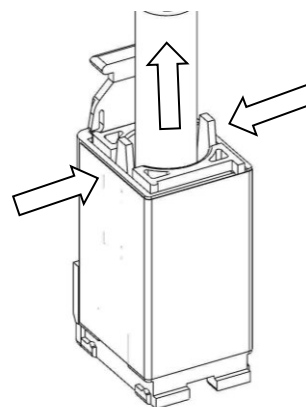

SQUEEZE LACING CAP SIDE LATCHES IN TOWARDS THE CABLE, PULL CABLE AND LACING CAP.

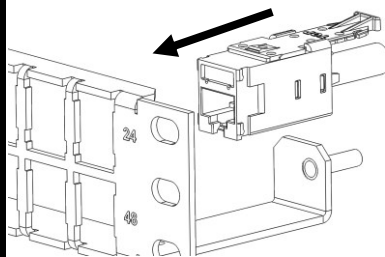

STEP 1:
INSERT HD JACK (PULL SLIDE LOCK ALL THE WAY BACK AND ON TOP) FROM REAR SIDE OF PANEL (JACK WILL GO IN ONLY ONE WAY WITH SLIDE LOCK UP).

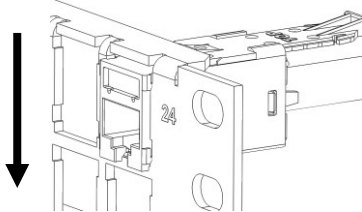

STEP 2:
ONCE JACK SHOULDERS COME INTO CONTACT WITH BACKSIDE OF PANEL, PRESS JACK DOWNWARD.

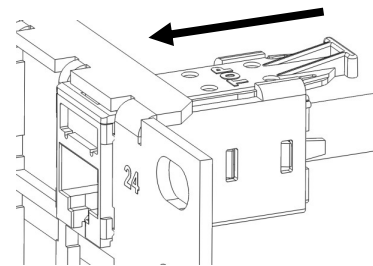

STEP 3:
PUSH ON SLIDE LOCK UNTIL THE FRONT IS FLUSH WITH THE JACK FACE

FACEPLATE INSTALLATION

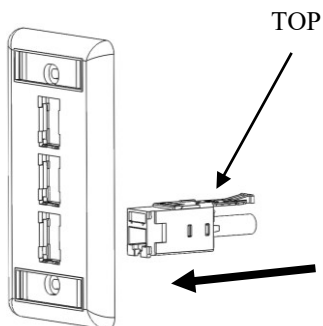

STEP 1:
INSERT HD JACK (PULL SLIDE LOCK ALL THE WAY BACK AND ON TOP) FROM REAR SIDE OF FACE PLATE (JACK WILL GO IN ONLY ONE WAY WITH SLIDE LOCK UP).

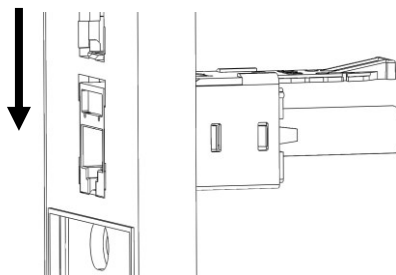

STEP 2:
ONCE JACK SHOULDERS COME INTO CONTACT WITH BACKSIDE OF FACE PLATE, PRESS JACK DOWNWARD.



STEP 3:
PUSH ON SLIDE LOCK UNTIL THE FRONT IS FLUSH WITH THE JACK FACE



**JACK REMOVAL
(STANDARD FOR ALL FACEPLATES AND PANELS)**

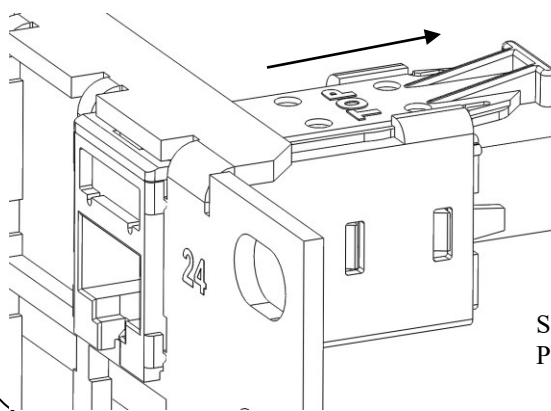

STEP 1:
PULL SLIDE LOCK BACK

STEP 2:
LIFT UP JACK HOUSING

STEP 3:
PULL OUT JACK HOUSING