

# RS232 DMX GATEWAY

DMX-RS232-GW

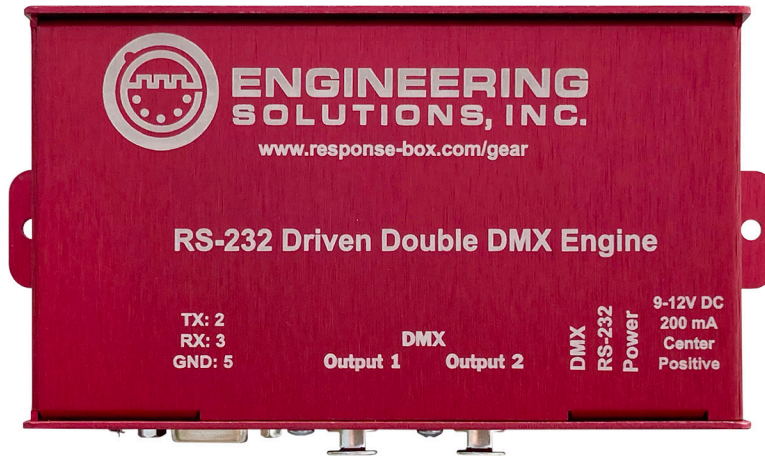

## DESCRIPTION

The DMX Gateway (DMX-RS232-GW) provides a full DMX universe of 512 channels. This product is RS232 based, can be connected directly to the InFusion Controller, and is programmed via Design Center 4.2 software or higher providing simple programming install for DMX systems.

## OPERATION

The DMX Gateway simultaneously processes information to and from one or more DMX devices, and provides a full DMX universe of 512 channels. All downstream communication from the Gateway is transmitted via defined/ standard DMX protocol packets. The Vantage Controller acts as the central control point and manages the information, load status and levels, making the interface simple to use.

## HIGHLIGHTS

The RS-232 DMX Engine is a self-contained DMX controller. It accepts simple, human-readable commands via RS-232 and uses these commands to generate, recall and cross fade between DMX scenes. Incoming serial data is buffered in the system's memory, multiple commands may be processed simultaneously.

## APPLICATIONS

The DMX-RS232-GW is ideal for systems incorporating DMX control within the automated Vantage lighting control system.

## FEATURES

- Full support of a universe of 512 DMX channels
- Programmed via Vantage's Design Center software (4.2 or higher)
- Maximum two Gateways per InFusion Controller
- Maximum 10 Gateways per system

PROJECT		LOCATION/ TYPE	
---------	--	-------------------	--

MULTI-VIEW LINE DRAWING

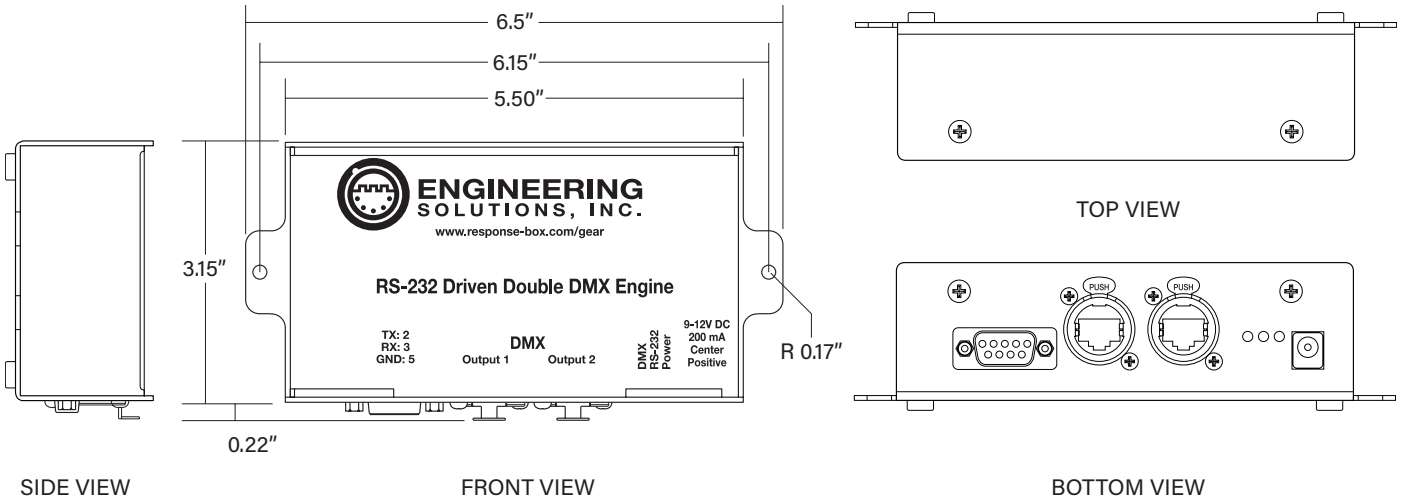

SPECIFICATIONS

Dimensions (HWD):	3.4" x 2.8" x 2.3" (86mm x 70mm x 58mm)
Model:	DMX-RS232-GW
Ambient Storage Temperature:	-40 - 140°F (-40 - 60°C)
Cooling:	Convection
DMX Bus	512 Channels of support
Maximum Power Draw	200 mA
Minimum Power Draw	40 mA
Voltage	9-15 VDC, PSU included
System Compatibility	InFusion, two Gateways per Controller with 10 count maximum per system

POWER SUPPLY

A standard International 9V DC power supply which delivers 300 mA is included. The 2.1mm x 5.5mm plug is center positive.

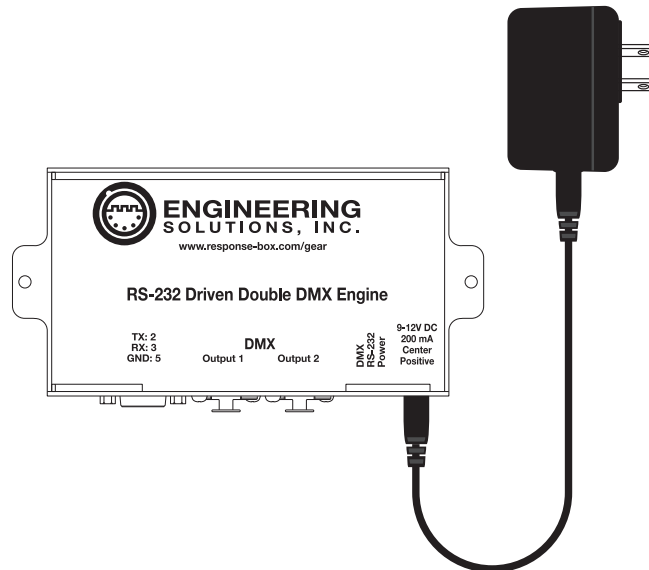

## WIRING DIAGRAM

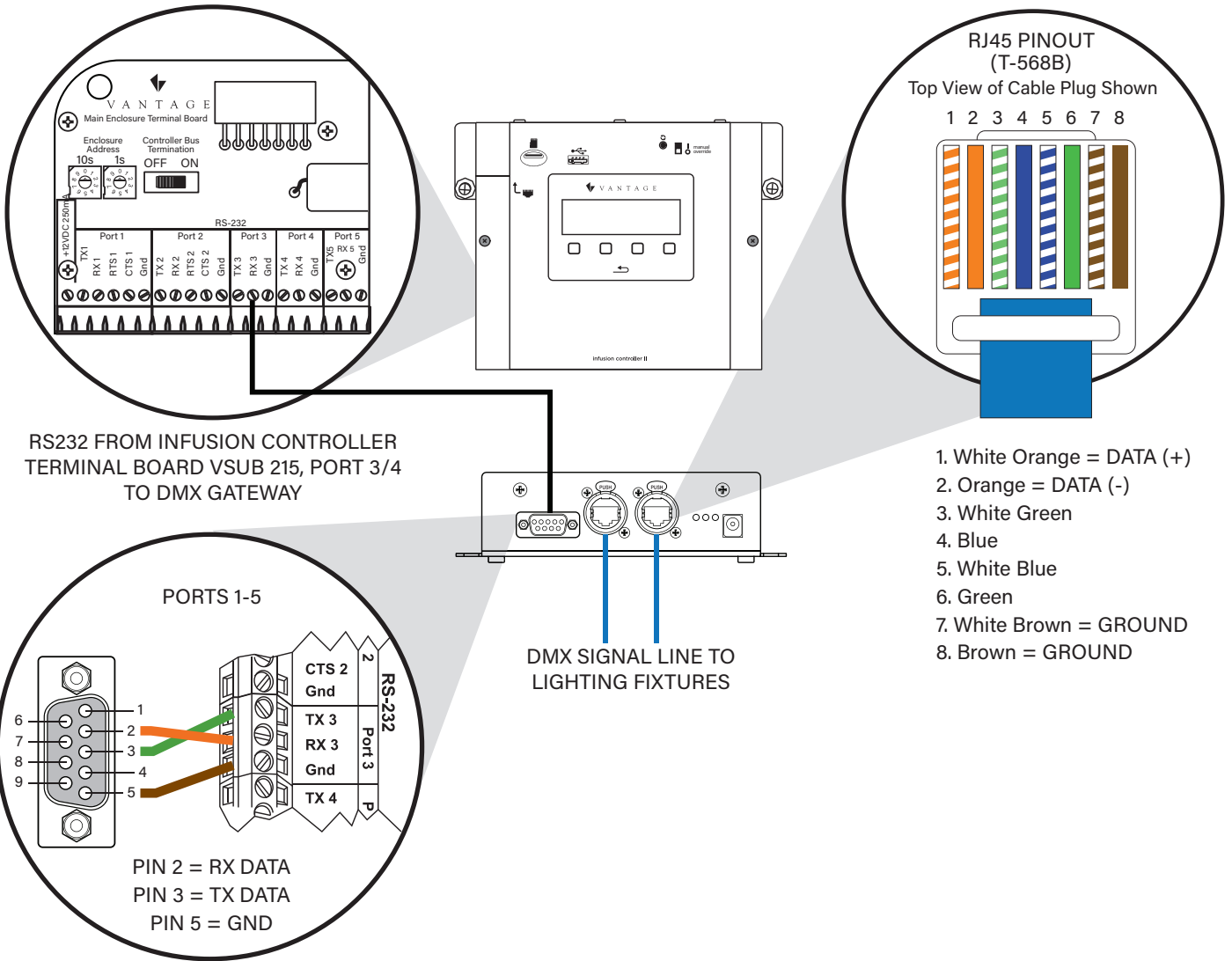

## ORDERING INFORMATION

Catalog #	Description	Voltage	Misc.
RS232-DMX-GW	RS232 DMX Gateway	9-15 VDC	Supports control of DMX