

Catalog Number • Numéro de Catalogue • Número de Catálogo: NB-CABLES

Country of Origin: Made in China • Pays d'origine: Fabriqué en Chine • País de origen: Hecho en China

INSTALLATION

Step 1: Mount NB-ROUTER to LMCP panel using its integrated DIN rail clip. The green power LED and Ethernet port should be left-of-center, as shown below.

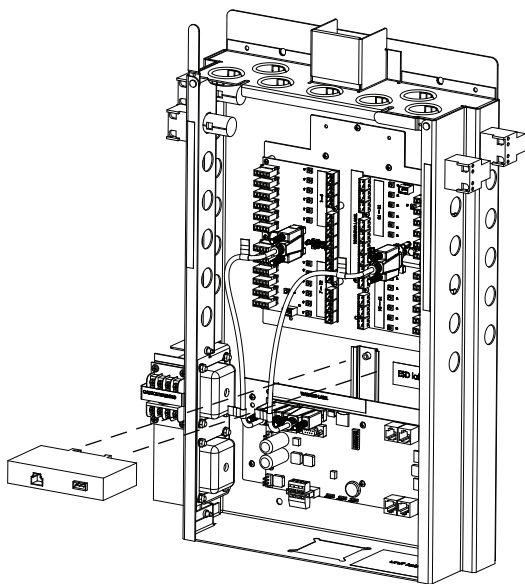

Step 2: Connect Green MSTP cable from NB-ROUTER to LMPI board. If necessary, remove the existing MSTP connectors on NB-ROUTER and LMPI. The MSTP terminations are not reversible. Use the flat and round edges of each connector to verify proper installation.

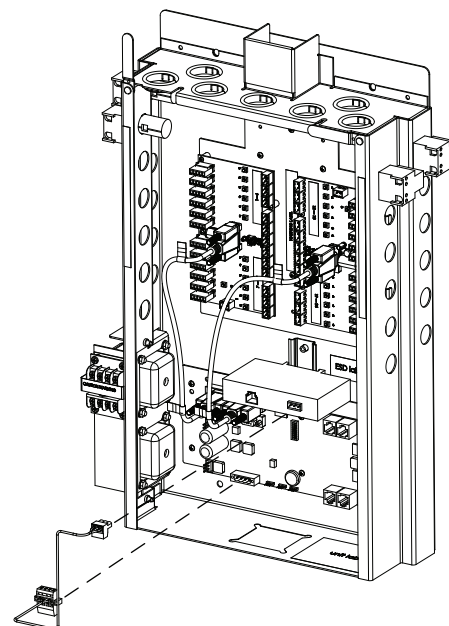

Step 3: Make sure the 24VDC/15VDC auxiliary power jumper is installed in the 24VDC position, as shown below.

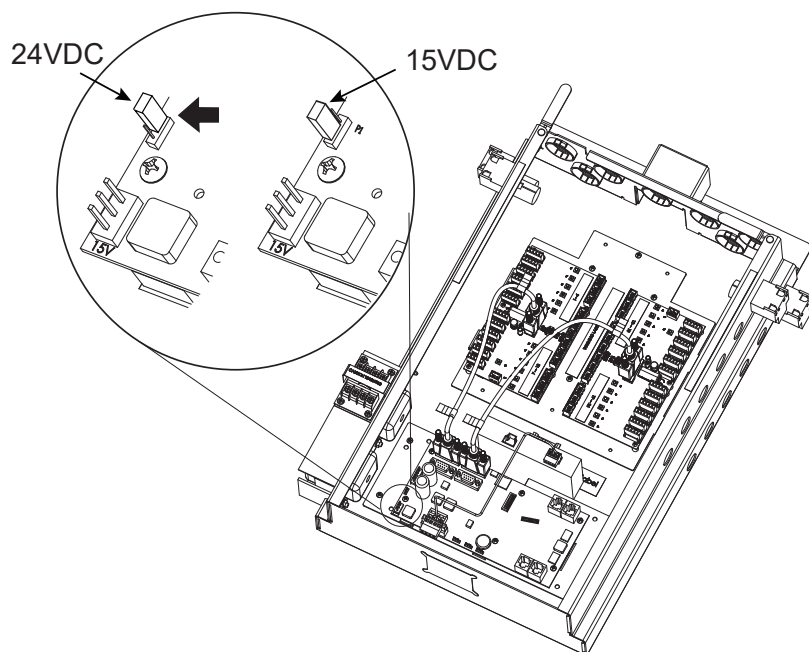

Step 4: Attach the power cable. If currently attached to the router, remove the 4-pin screw terminal from the router and screw down the red (DC+) and white (Common) wires as shown below. Once attached, re-insert the connector into the NB-ROUTER.



Step 5: Connect the other end of the power cable to the LMPI Auxiliary Power 3-pin header. The tab on the connector should be on the right once installed (red wire on top pin). The NB-ROUTER power LED should illuminate when power is applied to the panel. Installation is complete.

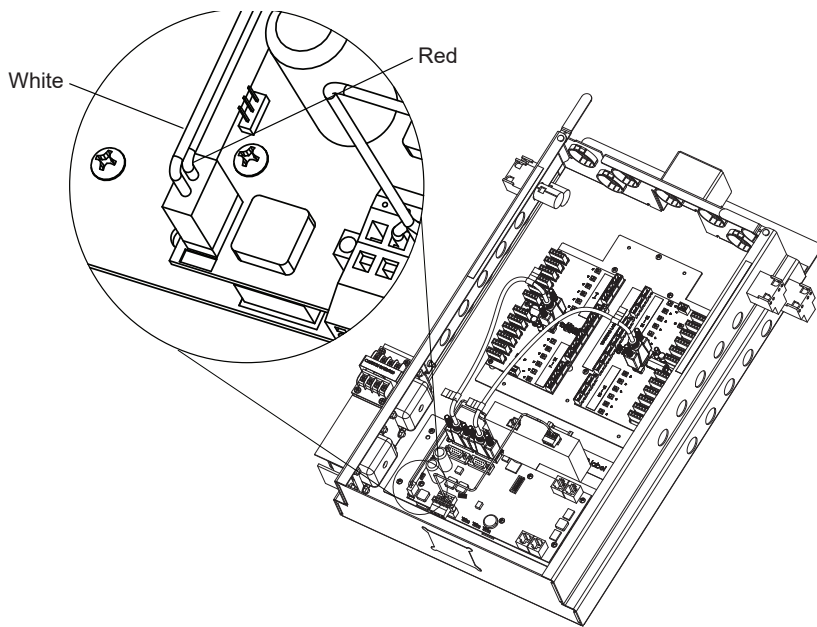

LMPI board with both cables attached

WARRANTY INFORMATION

Wattstopper warrants its products to be free of defects in materials and workmanship for a period of five (5) years. There are no obligations or liabilities on the part of Wattstopper for consequential damages arising out of, or in connection with, the use or performance of this product or other indirect damages with respect to loss of property, revenue or profit, or cost of removal, installation or reinstallation.

INFORMATIONS RELATIVES À LA GARANTIE

Wattstopper garantit que ses produits sont exempts de défauts de matériaux et de fabrication pour une période de cinq (5) ans. Wattstopper ne peut être tenu responsable de tout dommage consécutif causé par ou lié à l'utilisation ou à la performance de ce produit ou tout autre dommage indirect lié à la perte de propriété, de revenus, ou de profits, ou aux coûts d'enlèvement, d'installation ou de réinstallation.

INFORMACIÓN DE LA GARANTÍA

Wattstopper garantiza que sus productos están libres de defectos en materiales y mano de obra por un período de cinco (5) años. No existen obligaciones ni responsabilidades por parte de Wattstopper por daños consecuentes que se deriven o estén relacionados con el uso o el rendimiento de este producto u otros daños indirectos con respecto a la pérdida de propiedad, renta o ganancias, o al costo de extracción, instalación o reinstalación.