

**Catalog Numbers • Les Numéros de Catalogue • Los Números de Catálogo: EN-SW-11-ZB, EN-SW-20-ZB, EN-SW-22-ZB, EN-SW-41-ZB, EN-SW-50-ZB**

Country of Origin: Made in China • Pays d'origine: Fabriqué en Chine • País de origen: Hecho en China

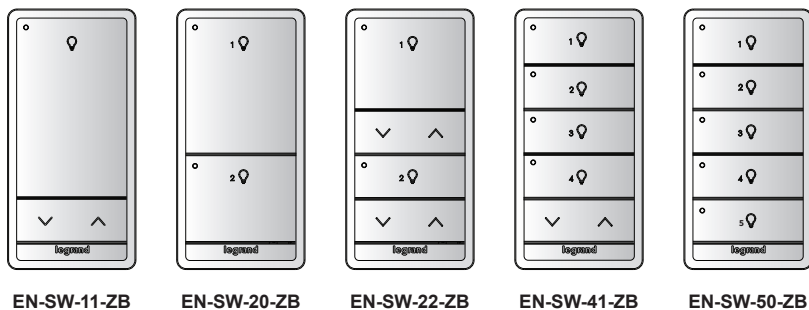

## DESCRIPTION

The SW Series Slim Switches are programmable, wireless control devices for manual on/off, dimming, and scene control of one or more loads from one or more locations. SW Series switches are available in multiple colors and may have custom text or icons factory printed onto buttons via our custom engraving offering.

## BATTERY SAFETY

- Never introduce the product and/or its batteries to extreme temperatures or altitudes during use, storage, or transportation.
- Never expose batteries to excessive heat such as sunshine, fire or the like.
- Never damage or use damaged devices / batteries.
- Never short circuit the batteries.
- Always ensure batteries are installed with their correct polarity.
- Ensure batteries are removed from the product after they have become exhausted.
- Batteries should only be replaced by maintenance staff or other professional.
- This is professional equipment intended for commercial applications only.
- **CAUTION:** Risk of fire or explosion if the battery is replaced incorrectly.

## SÉCURITÉ DE LA BATTERIE

- N'exposez jamais le produit et/ou ses batteries à des températures ou altitudes extrêmes pendant l'utilisation, le stockage ou le transport.
- N'exposez jamais les batteries à une chaleur excessive telle que le soleil, le feu ou autre.
- N'endommagez ni n'utilisez jamais d'appareils/batteries endommagés.
- Ne court-circuitiez jamais les batteries
- Assurez-vous toujours que les piles sont installées avec leur polarité correcte
- Assurez-vous que les piles sont retirées du produit une fois qu'elles sont épuisées.
- Les batteries ne doivent être remplacées que par le personnel de maintenance ou tout autre professionnel.
- Il s'agit d'un équipement professionnel destiné uniquement à des applications commerciales.
- **ATTENTION :** Risque d'incendie ou d'explosion si la batterie n'est pas remplacée correctement

## SPECIFICATIONS

Power ..... Battery, (1) CR2354 Battery, 3VDC (included)  
 Connection to PLUS network ..... Wireless  
 Wireless (2.4GHz) Range: ..... 30ft line-of-sight to repeater device, 15ft through standard wall materials  
 Environment ..... For Indoor Use Only  
 Operating Temperature ..... 32° to 104°F (0° to 40°C)  
 Storage Temperature..... 23° to 176°F (-5° to 80°C)  
 Relative Humidity ..... 5% to 95% (non-condensing)  
 Weight ..... 67 g (2.4 oz)

### Certifications

- UL and cUL listed (UL916)
- CE (Conformity with all EC Directive requirements)
- FCC Part 15 Class B compliant
- FCC ID:Q4B-ZBSD
- IC:23947-ZBSD
- RoHS Compliant
- Product Environmental Profile (PEP)

The radio frequency range of this product is 2405MHz-2480MHz; the maximum radio transmission power is 8dBm. Legrand declares that this product is in compliance with essential requirements and other relevant provisions of Directive 2014/53/EU.



This product bears the selective sorting symbol for Waste electrical and electronic equipment (WEEE). This means that this product must be handled pursuant to European directive 2012/19/EU in order to be recycled or dismantled to minimize its impact on the environment. User has the choice to give his product to a competent recycling organization or to the retailer when he buys a new electrical or electronic equipment

 This symbol indicates DC voltage.

Do not apply cleaning solvent directly onto unit. Apply cleaning solvent onto a cloth, then wipe the unit clean. Dry device after cleaning.

## WIRELESS SYSTEM OVERVIEW

This illustration shows how each component is easily integrated into the Wattstopper PLUS System.

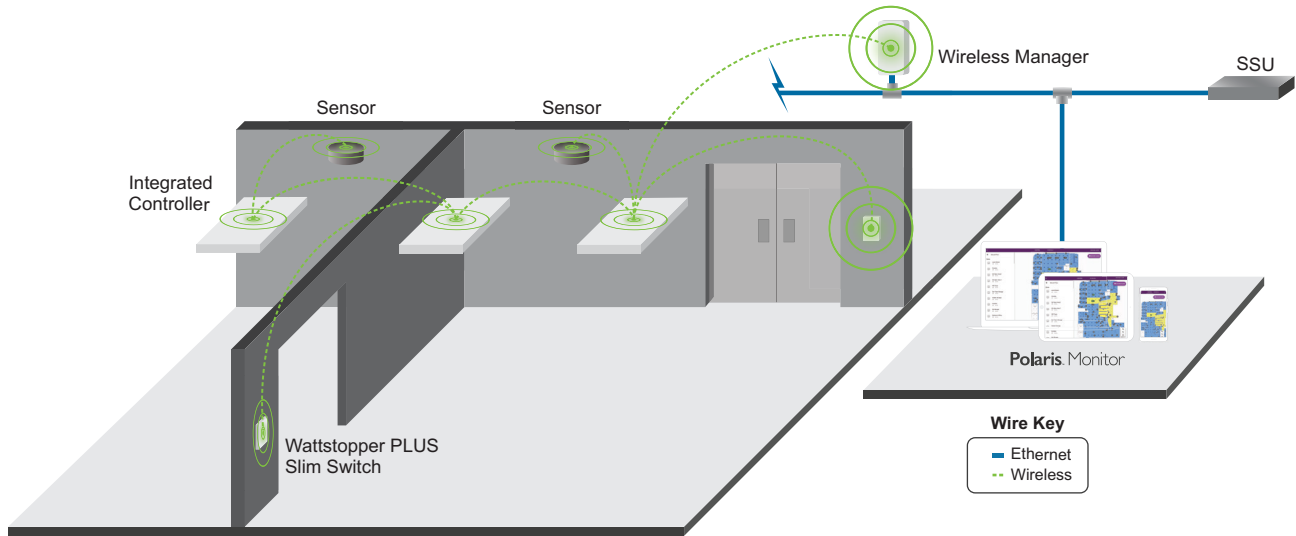

## BUTTONS AND INDICATORS

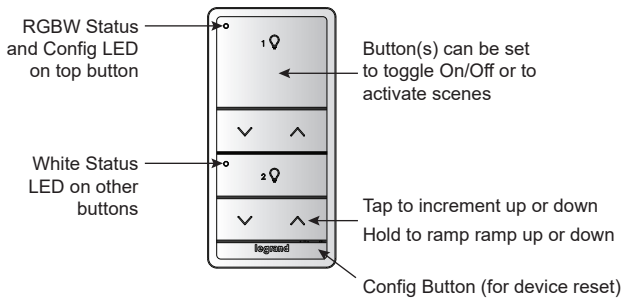

### Pre-programmed LED Operation

Before being programmed, device LEDs are primarily used to indicate pairing status with a PLUS wireless network. Upon powering, EN-SW Slim Switches will begin searching for a PLUS network, indicated by a short green flash every 3 seconds. When attempting to join a PLUS network, the green LED will flash rapidly. After successfully joining, the green LED will illuminate solidly for 2 seconds and then turn off.

### Normal LED Operation (After Programming)

In normal operation, the primary function of device LEDs is to communicate status of controlled loads. Whenever a button or rocker is tapped, the switch will wake and all status LEDs will report the state of the loads or scenes controlled by each button. LEDs on any buttons controlling loads or scenes that are now active will briefly illuminate white, while other LEDs will remain off.

If an EN-SW switch is ever woken while battery is low, the Config LED on button 1 will also flash red (red/off or red/white based on button 1 load or scene state) indicating that the device battery should be replaced.

### Resetting the Switch

To reset a switch to factory state, the Config button must first be unlocked. Press and hold the Config button for 5 seconds and the Status LED will flash to indicate it is unlocked (two quick green flashes). Once unlocked, tap the Config Button 10 times to initiate a reset.

## INSTALLING THE SWITCH

Wattstopper PLUS Slim Switches support two installation methods: surface mount or wall-box mount.

**NOTE:** The switches may not be installed into wall boxes with line voltage wiring. In applications such as retrofit, any such wiring must be removed from the wallbox prior to installation.

Wattstopper PLUS Slim Switches are for commercial use only.

**NOTE:** Before mounting, the battery protection tab should be removed.

### Surface Mount:

Surface mounting requires use of a Legrand radiant® wall plate (sold separately). The adhesive pad is suitable for mounting to multiple materials including drywall, metal, wood, glass, and some plastics.

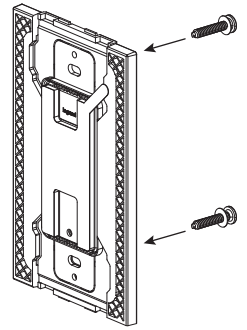

1. Remove the wall box screws from the switch.
2. Hook the Radiant plate on the upper plate mount bracket, then press the bottom of the plate into the switch to snap on the plate.
3. Peel the adhesive protector off of the rear of the switch.
4. Align the switch with the wall and press it firmly into the mounting surface, holding pressure for 5 seconds.

For **surface mounting in multi-gang applications**, snap-off side alignment wings are available to assist in proper alignment.

1. Press and jiggle the wall box screws from the rear to remove them from the switches.
2. Using an appropriately sized multi-gang Radiant plate (sold separately), attach each switch to the plate by hooking the plate on the upper plate mount bracket of the switch, then pressing the bottom of the plate into the switch to snap on the plate.
3. Peel the adhesive protector off of the rear of each switch.
4. Align the assembled switch bank with the wall and press it firmly into the mounting surface, spreading a firm pressure evenly across the switch bank for 5 seconds.

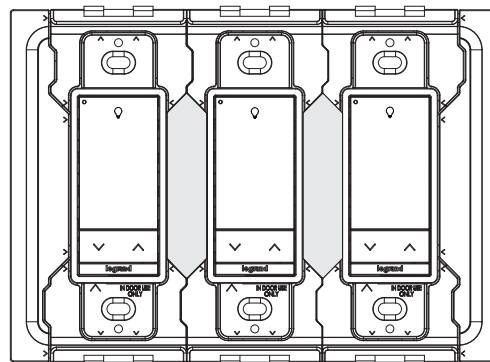
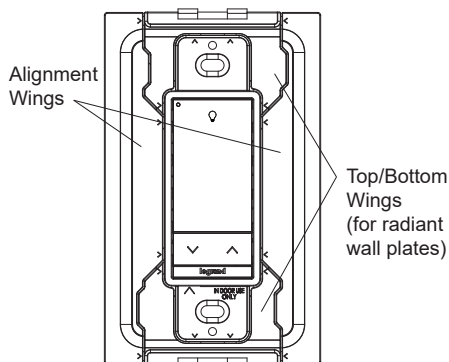

Example of 3 gang installation with alignment wings removed

### Wall box mount:

Wall box mounting allows for use of any standard decorator-sized wall plate (not included). If using any plate other than a Legrand radiant wall plate, the top and bottom radiant mount wings should be removed from the switch.

**NOTE:** This is a Class 2 device and should not be installed next to Class 1 power.

1. Twist/cut to remove side alignment wings. If not using a radiant wall plate, also remove the top and bottom wings).
2. Use included screws to secure switch to wall box.
3. Install wall plate per manufacturer instructions.

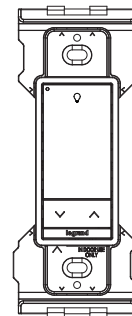

Leave top/bottom wings if using a radiant wall plate

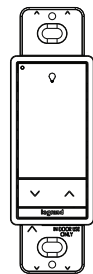

Remove top/bottom wings if using any other wall plate

---

## REPLACING THE BATTERY

---

**NOTE:** During battery replacement, some electrical components are exposed to static discharge from the user which could damage the switch. It is recommended to discharge any static from your person prior to proceeding. Contacting the switch's battery holder will equalize charge and avoid damage from static discharge.

To replace the battery:

1. Remove the faceplate from the switch.
2. Locate the prying location at the bottom left corner of the switch frame (slightly below the Legrand badge), as shown. Insert a small prying tool and pull the corner of the switch frame away from the wall. The switch will detach from the mounting plate with frame and buttons intact.
3. Locate the battery at the rear of the device. Remove the battery and replace with a new CR2354 battery.
4. Press the switch back into the mounting plate, and reinstall the faceplate. Removed battery is non-reusable and should be disposed off properly.

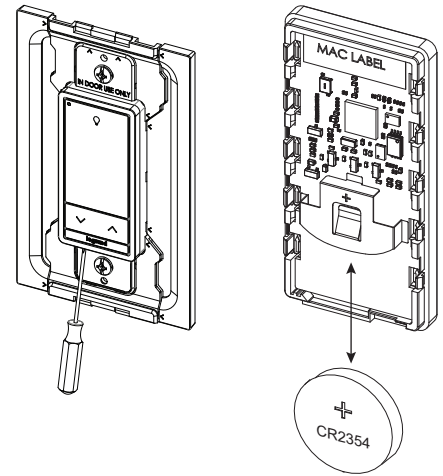

## FCC REGULATORY STATEMENTS

This device complies with part 15 of the FCC Rules. Operation is subject to the following two conditions: (1) This device may not cause harmful interference, and (2) this device must accept any interference received, including interference that may cause undesired operation.

**NOTE:** This equipment has been tested and found to comply with the limits for a Class B digital device, pursuant to part 15 of the FCC Rules. These limits are designed to provide reasonable protection against harmful interference in a residential installation.

This equipment generates uses and can radiate radio frequency energy and, if not installed and used in accordance with the instructions, may cause harmful interference to radio communications. However, there is no guarantee that interference will not occur in a particular installation. If this equipment does cause harmful interference to radio or television reception, which can be determined by turning the equipment off and on, the user is encouraged to try to correct the interference by one or more of the following measures:

- Reorient or relocate the receiving antenna.
- Increase the separation between the equipment and receiver.
- Connect the equipment into an outlet on a circuit different from that to which the receiver is connected.
- Consult the dealer or an experienced radio/TV technician for help.

## RF exposure warning

This equipment complies with FCC radiation exposure limits set forth for an uncontrolled environment. At least 20 cm of separation distance between this device and the user's body must be maintained at all times.

Any changes or modifications not expressly approved by The Watt Stopper Inc. could void the user's authority to operate the equipment.

## IC Caution:

This device complies with Industry Canada license-exempt RSS standard(s). Operation is subject to the following two conditions:

- (1) This device may not cause interference, and
- (2) This device must accept any interference, including interference that may cause undesired operation of the device.

Le présent appareil est conforme aux CNR d'Industrie Canada applicables aux appareils radio exempts de licence. L'exploitation est autorisée aux deux conditions suivantes:

- (1) l'appareil ne doit pas produire de brouillage, et
- (2) l'utilisateur de l'appareil doit accepter tout brouillage radioélectrique subi, même si le brouillage est susceptible d'en compromettre le fonctionnement.

## RF exposure warning

This equipment complies with IC radiation exposure limits set forth for an uncontrolled environment. This equipment should be installed and operated with minimum distance 20cm between the radiator & your body.

Cet équipement est conforme aux limites d'exposition aux radiations de la IC définies pour un environnement non contrôlé. Cet équipement doit être installé et utilisé à une distance minimale de 20 cm entre le radiateur et votre corps.

**NOTE:** No rights or licenses under patents owned or controlled by third parties, express or implied, are granted to use third-party devices in combination with these products in a wireless mesh network, or to use third-party services to access, monitor or control these products in a wireless mesh network via the Internet or another external wide area network. Separate license rights may need to be obtained from such third parties for such devices, combinations and services.

### WARRANTY INFORMATION

Wattstopper warrants its products to be free of defects in materials and workmanship for a period of five (5) years. There are no obligations or liabilities on the part of Wattstopper for consequential damages arising out of, or in connection with, the use or performance of this product or other indirect damages with respect to loss of property, revenue or profit, or cost of removal, installation or reinstallation.

### INFORMATIONS RELATIVES À LA GARANTIE

Wattstopper garantit que ses produits sont exempts de défauts de matériaux et de fabrication pour une période de cinq (5) ans. Wattstopper ne peut être tenu responsable de tout dommage consécutif causé par ou lié à l'utilisation ou à la performance de ce produit ou tout autre dommage indirect lié à la perte de propriété, de revenus, ou de profits, ou aux coûts d'enlèvement, d'installation ou de réinstallation.

### INFORMACIÓN DE LA GARANTÍA

Wattstopper garantiza que sus productos están libres de defectos en materiales y mano de obra por un período de cinco (5) años. No existen obligaciones ni responsabilidades por parte de Wattstopper por daños consecuentes que se deriven o estén relacionados con el uso o el rendimiento de este producto u otros daños indirectos con respecto a la pérdida de propiedad, renta o ganancias, o al costo de extracción, instalación o reinstalación.