

REVISIONS						
ECN#	ZONE	REV	DESCRIPTION	REV BY	CHK BY	DATE
03709		01	INITIAL RELEASE	HJK	J.LUCY	09/12/08
03909		02	UPDATED ITEM #1	CMV	J. LUCY	06/04/09
04850		03	REVISED TO LEGRAND FORMAT, CHGD LABEL	TSD	JPQ	3/2/2016

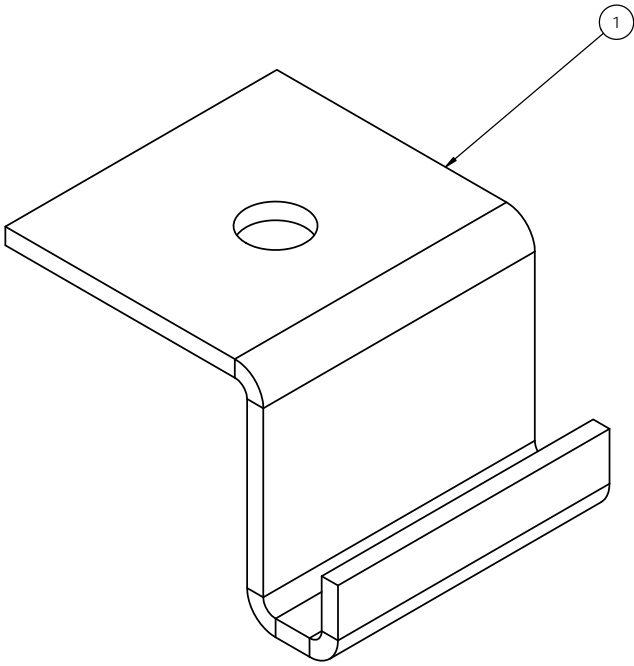

NOTE:
 1. PACKAGE COMPONENTS INDIVIDUALLY
 2. PLACE COMPONENT IN A PLASTIC BAG AND ATTACH ITEM 2 TO BAG

UNLESS OTHERWISE SPECIFIED, ALL DIMENSIONS APPLY AFTER FINISH. ALL PACKAGING IN ACCORDANCE WITH SPEC #71700217. BREAK ALL SHARP METAL EDGES.

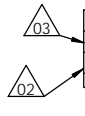

3	1				BAG, PLASTIC
2	1	OR-70400953			BLANK LABEL, WHITE THERMAL 4.0" X 2.0" LEGRAND
1	1	OR-41700490B			CLIP, RUNWAY WALL
REV		QTY	PART NUMBER	SUPPLIER/VENDOR	DESCRIPTION
<small>UNLESS OTHERWISE STATED DIMENSIONS ARE IN INCHES</small> <small>TOLERANCES: FRACTIONAL ± 1/16" BEND ± 1° ANGULAR MATCH ± 1° TWO PLACE DECIMAL ± .02 THREE PLACE DECIMAL ± .010</small> <small>*** NOTICE *** THIS DOCUMENT CONTAINS CONFIDENTIAL AND/OR PROPRIETARY INFORMATION INTENDED FOR USE ONLY BY THE INDIVIDUAL(S) PROVIDED. NEITHER THIS DOCUMENT, NOR ANY INFORMATION CONTAINED HEREIN, MAY BE COPIED, DISTRIBUTED, DISCLOSED TO ANY THIRD PARTY OR USED IN ANY MANNER OTHER THAN FOR WHICH IT HAS BEEN PROVIDED, WITHOUT THE PRIOR WRITTEN CONSENT OF LEGRAND, INC.</small>					
MATERIAL		SEE INDIVIDUAL COMPONENTS			
FINISH		SEE INDIVIDUAL COMPONENTS			
		NAME	DATE	SIZE	CAD FILE
		DWN	HJK 09/10/08	C	P982078HB1
		CHK	JLUCY 09/12/08		DWG NO
		APPR	A.M. 09/12/08	SCALE	2:1
					SHEET
					1 OF 1
		TITLE		S CLIP BRACKET FASTEN RW TO WALL, BLACK	
		<small>125 EUGENE O'NEILL DRIVE NEW LONDON, CT 06320 TEL: 860-445-3800 FAX: 860-405-2990 WWW.ORTRONICS.COM</small>			