

CONTINUOUS 0-10V DIMMING PIR INDOOR/ OUTDOOR PHOTO/MOTION SENSOR WITH BLUETOOTH® TECHNOLOGY

FSP-3X1 SERIES

Designed for LED fixtures and
rated for extreme temperatures

Fully adjustable high and low
dimmed light levels

Choice of four lenses for mounting
heights from 8 ft. to 40 ft.

Adjustable time delay and cutoff delay



Continuous dimming for Energy
Code Compliance

Adjustable via the iOS® or Android®
Sensor Configuration App

Hold off setpoint with automatic
calibration option for convenience
and added energy savings



DESCRIPTION

The FSP-3x1 sensors provide continuous dimming intensity control based on motion and/or daylight contribution. They control 0-10 VDC LED drivers or dimming ballasts, as well as non-dimming ballasts and, with an FSP-Lx Lens, are rated for wet and cold locations. All control parameters are adjustable via the iOS or Android Sensor Configuration App capable of storing and transmitting unlimited sensor profiles. The FSP-3x1 family is available in three different voltage configurations adding flexibility to your fixture design or project.

OPERATION

Typically, the sensor ramps lighting On to the selected High mode level when motion is detected and the ambient light level is below the hold off setpoint. After the sensor stops detecting motion and the time delay elapses, lights fade to the Low mode level. If there is no motion during the subsequent cut off time delay, the lights will turn Off. For dusk to dawn control, the integral photocell can switch the lights On/Off and dim based on the ambient light level, so that lighting remains on overnight even without motion detection, for increased security.

FEATURES

- Provides line voltage On/Off switching
- Works with 0-10V dimming ballasts or LED drivers
- Continuous dimming provides appropriate light levels based on ambient light conditions
- High and low modes fully adjustable from 0 to 10V
- Time delay from 5 to 30 minutes
- Optional daylighting setpoints feature automatic calibration, or permit manual adjustment
- Optional cut off delay
- Adjustable ramp up and fade down times
- Polycarbonate construction; flame retardant, UV resistant, impact resistant, recyclable
- Optional shroud with integrated lens to block high-angle light
- Smartphone or tablet application stores an unlimited number of sensor profiles for quick setup and adjustment of multiple sensors (download Sensor Configuration App)
- UL244A and UL508; IP66 rated (when fully assembled and installed in an IP66-rated fixture) for use in wet locations
- This product meets the materials restrictions of RoHS

APPLICATIONS

The slim, low-profile design of the FSP-3x1 series is designed for installation inside the bottom of a light fixture body. When fully assembled and installed in an IP66-rated fixture, the sensor, and FSP-Lx lenses are IP66 rated. The sensor is ideal for areas such as parking facilities, filling stations, pedestrian pathways, and warehouses. A choice of four lenses ensures complete coverage for mounting heights up to 40'.

CONFIGURATION

Initial setup and subsequent sensor adjustments are made using the iOS or Android Sensor Configuration App. This app enables adjustment of parameters including high and low modes, sensitivity, time delay, cut off and more. The smartphone or tablet app is also used to initiate automatic calibration of the FSP-3x1 ambient light level setpoint. The setpoint is used to hold the controlled lighting off or at a low level when there is sufficient daylight. The wireless tool stores an unlimited number of sensor parameter profiles to speed configuration of multiple sensors.

Bluetooth communication ranges can vary depending on the device, as well as mobile carrier. Wattstopper recommends devices with Bluetooth 5.0. Iphone 8 and Samsung Galaxy S8 and later devices are recommended for optimal performance.

PROJECT

LOCATION/
TYPE

SPECIFICATIONS

- Input voltage:
 - FSP-301, 12–32VDC
 - FSP-311, 120/277VAC, 230–240VAC (single phase); 50/60Hz
 - FSP-321, 100–347VAC (single phase) or 208/230/480VAC (phase-to-phase); 50/60Hz
- Load ratings (FSP-311, FSP-321):
 - @120VAC 0–800W tungsten, ballast, LED driver; 1/6hp motor
 - @230–240V 0–300W ballast, LED driver
 - @277VAC 0–1200W ballast, LED driver; 1/6hp motor
 - @347V 0–1200W ballast, LED driver; (FSP-321 only)
 - @480V 0–1200W ballast; (FSP-321 only)
- Wiring Terminals (FSP-301, FSP-311 only)
 - COM, +VDC, Control (FSP-301): 16–18AWG
 - Line Voltage (FSP-311): 16–18AWG
 - Low Voltage (for 0–10V Dimming): 18–20AWG
- Lead Length (FSP-321 only): 12" (30.5 cm)
- Relay life rating (FSP-311 & FSP-321): 200,000 cycles (120/277VAC); 50,000 cycles (230VAC)
- Maximum recommended distance between mobile device running Configuration App and the sensor: 100 ft.
- High mode: 0–10V; default 10V
- Low mode: Off, 0–9.8V; default 1V
- Time delay: 30 sec., 1–30 min.; default 5 min.
- Cut off delay: none, 1–59 min. 1–5 hrs.; default 1 hr.
- Sensitivity: On-Fix, Off-Fix, Low, Med, Max
- Hold-Off Setpoint: Disable, 1–250 fc, Auto; default disabled
- Photocell On/Off: 1–250 fc; default disabled
- Ramp up time: none, 1–60 sec.; default disabled
- Fade down time: none, 1–60 sec.; default disabled
- Operating temperature: -40 to 167°F (-40 to 75°C)
- Operating Humidity: 20–90%
- Weight: FSP-301, 2.1 oz (59 g); FSP-311, 2.8 oz (80 g); FSP-321, 5.5 oz (155 g)
- Collar Dimensions
 - Collar: 1.30" diameter (33.0mm)
 - Collar height: 0.64" (16.3mm)
- UL and cUL listed (E101196)
- Five year warranty

DIMENSIONS & MOUNTING

Sensor Dimensions

FSP-301/FSP-311

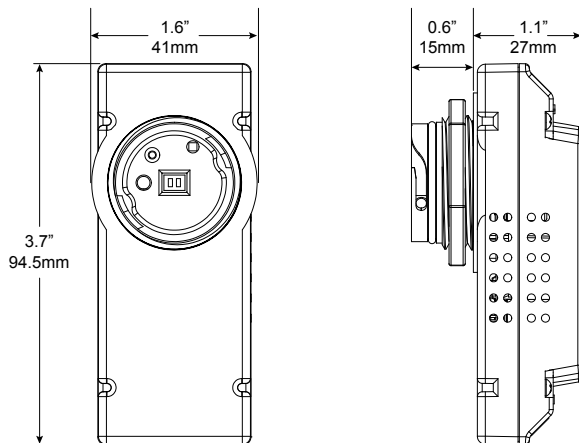

FSP-321

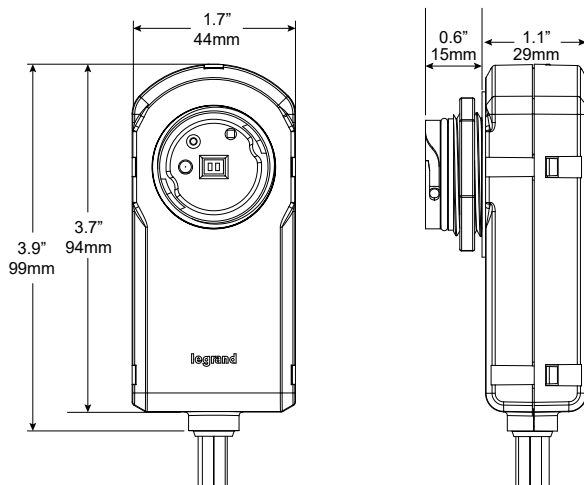

Sensor Mounting

An optional collar can be installed in place of the tightening nut on the FSP-3x1.

An optional shroud with integrated lens can be installed instead of the collar and a regular lens. The shroud blocks high-angle light coming from the fixture, to improve photocell performance.

FSP-301/FSP-311

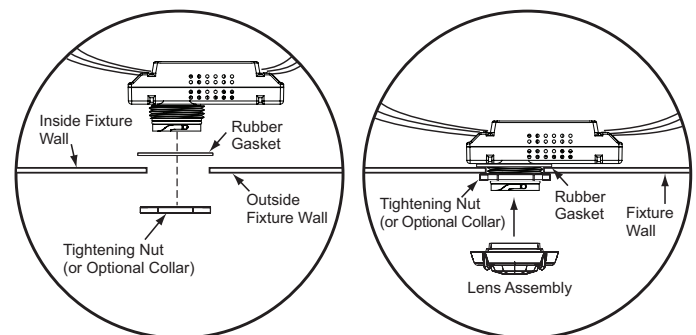

FSP-321

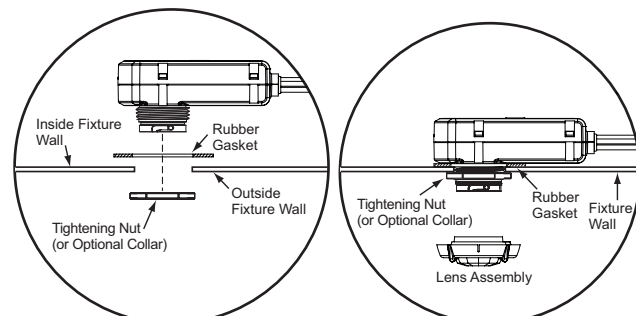

The FSP-3x1 accommodates fixture wall thickness up to 0.125" (3.18mm).

WIRING

FSP-301 Wiring with Power Pack

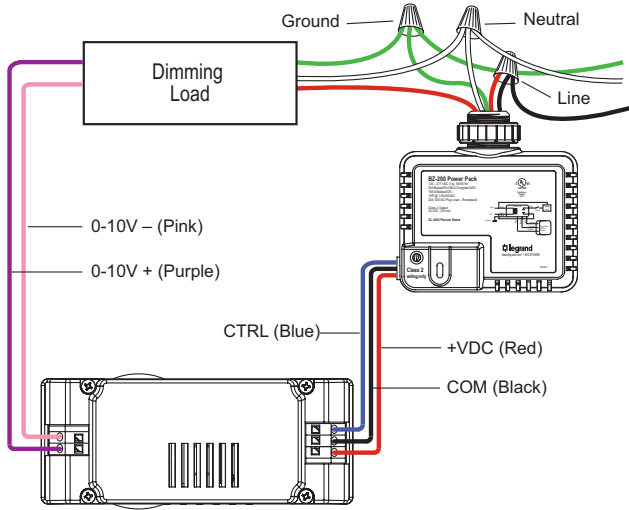

FSP-301 Wiring with Dim-to-Off Driver with Aux Input

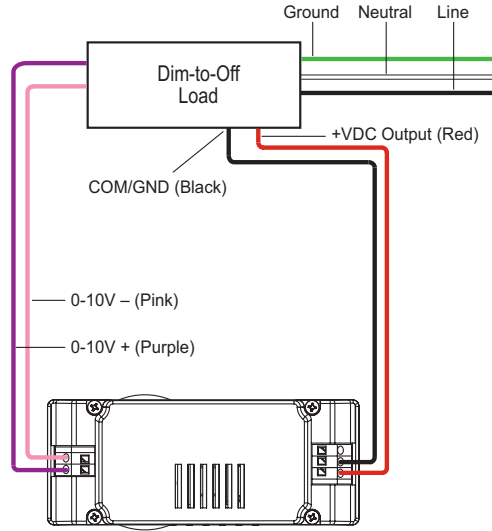

FSP-311 Dimming Wiring

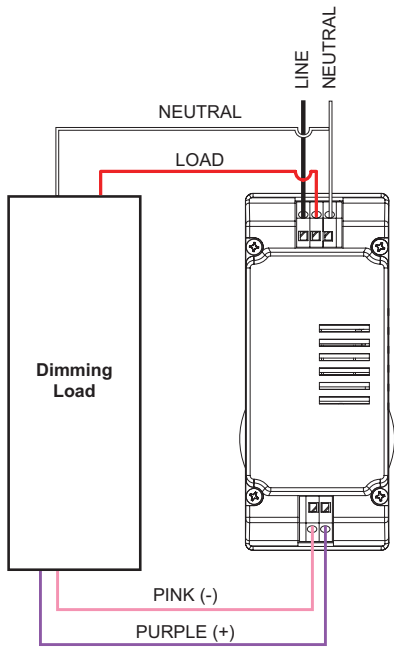

NOTE: Per UL, the 0-10V negative dimming wire color has been changed from gray to pink.

FSP-311 Non-Dimming Wiring

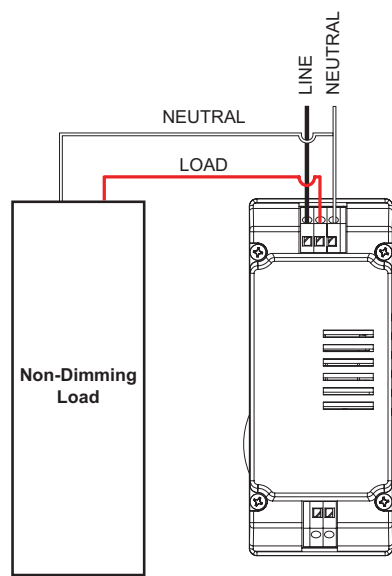

FSP-321 Dimming Wiring

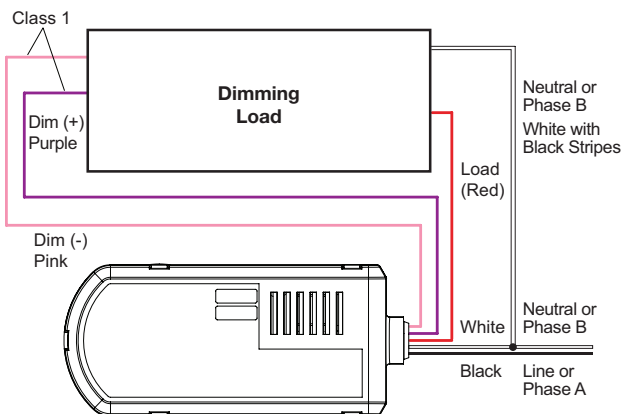

FSP-321 Non-Dimming Wiring



ORDERING INFORMATION

Catalog #	Color	Description	Voltage
<input type="checkbox"/> FSP-301	White	Fixture mount PIR motion sensor, Low Voltage, with Bluetooth technology	12-32 VDC
<input type="checkbox"/> FSP-311	White	Fixture mount PIR motion sensor, Line Voltage, with Bluetooth technology	120/277VAC, 50/60Hz or 230VAC, 50Hz
<input type="checkbox"/> FSP-321	White	Fixture mount PIR motion sensor, Universal Voltage, with Bluetooth technology	100-347VAC (single phase) or 208/230/480VAC (phase-to-phase); 50/60Hz
<input type="checkbox"/> FSP-L2	White	360° lens, maximum coverage 48' diameter from 8' height	
<input type="checkbox"/> FSP-L2-B	Black		
<input type="checkbox"/> FSP-L2-BR	Bronze		
<input type="checkbox"/> FSP-L2-G	Grey		
<input type="checkbox"/> FSP-L2-S	White	360° lens, maximum coverage 48' diameter from 8' height, with shroud; Minimizes high-angle light contribution to photocell	
<input type="checkbox"/> FSP-L3	White	360° lens, maximum coverage 40' diameter from 20' height	
<input type="checkbox"/> FSP-L3-B	Black		
<input type="checkbox"/> FSP-L3-BR	Bronze		
<input type="checkbox"/> FSP-L3-G	Grey		
<input type="checkbox"/> FSP-L3-S	White	360° lens, maximum coverage 40' diameter from 20' height, with shroud; Minimizes high-angle light contribution to photocell	
<input type="checkbox"/> FSP-L7	White	360° lens, maximum coverage 100' diameter from 40' height	
<input type="checkbox"/> FSP-L7-B	Black		
<input type="checkbox"/> FSP-L7-BR	Bronze		
<input type="checkbox"/> FSP-L7-G	Grey		
<input type="checkbox"/> FSP-L7-S	White	360° lens, maximum coverage 100' diameter from 40' height, with shroud; Minimizes high-angle light contribution to photocell	
<input type="checkbox"/> FSP-C1-W	White	Small collar, for use with FSP-L2 and FSP-L3 lenses (Optional aesthetic collar to transition from fixture housing to lens) Note: Not used with lenses that include shroud	
<input type="checkbox"/> FSP-C2-W	White	Large collar, for use with FSP-L7 lens (Optional aesthetic collar to transition from fixture housing to lens) Note: Not used with lens that includes shroud	

Note: Unless used with a driver or ballast with a low voltage power supply, the FSP-301 requires a Wattstopper power pack (ordered separately) to operate. FSP-Lx series lens required for operation; order lens separately.

Smartphone commissioning application required for configuration. Download separately.



The Bluetooth® word mark and logos are registered trademarks owned by the Bluetooth SIG, Inc. and any use of such marks by Wattstopper is under license.

Google Play and the Google Play logo are trademarks of Google Inc.

The Apple logo, iPhone, iPod touch, and iTunes are trademarks of Apple Inc., registered in the U.S. and other countries.