

SELECTABLE MODE CONTINUOUS DIMMING PIR FIXTURE INTEGRATED INDOOR/MOTION/PHOTO SENSOR

FSP-2X2D SERIES



FSP-202D

FSP-212D

PRODUCT OVERVIEW

The FSP-2x2D series are passive infrared (PIR) indoor sensors that raise or lower the electric lighting level based on motion and daylight contribution. Four distinct operating modes are available to ensure the desired lighting response for your application space. The integral photocell maintains a desired lighting level utilizing advanced

continuous dimming control. Each mode is configurable via rotary trim pots. These enable adjustment of sensor parameters including: operating mode, desired light level, sensitivity, time delay, cut off and more. These sensors is designed for installation inside the light fixture's body, and is rated for wet and cold locations.

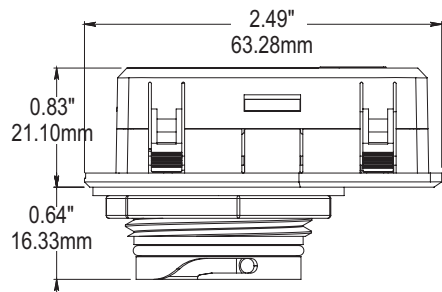

FSP-202D dimensions

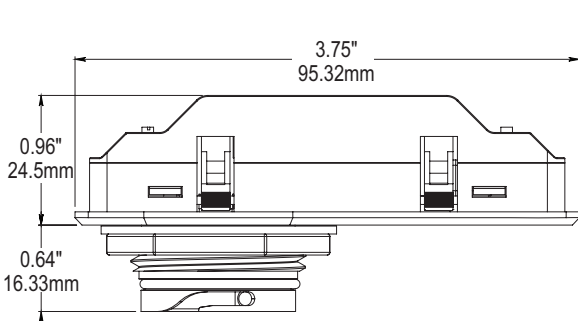
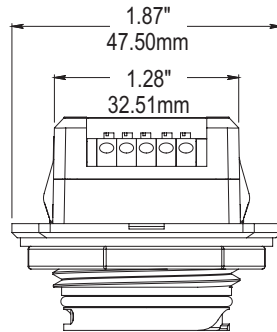

FSP-212D dimensions

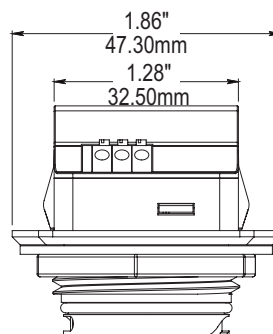

MODELS	
FSP-202D – 12-32VDC	Use with dim-to-off driver or ballast or with Wattstopper power pack
FSP-212D – 120/277VAC, 50/60Hz	
SPECIFICATIONS & FEATURES	
Load Ratings (FSP-212D):	
@ 120V 0-800W tungsten, ballast, LED driver; 1/6hp motor	
@ 230-240V 0-300W ballast, LED driver	
@ 277V 0-1200W ballast, LED driver; 1/6hp motor	
Do not use FSP-212D with non-isolated LED drivers	
Current consumption (FSP-202D): 10 mA max.	
0-10V sinking current: 25mA	
Three interchangeable lenses for mounting between 8' and 40'	
Choice of 4 operating modes plus service mode	
Adjustable high or low dim level (1 to 10V)	
Adjustable time delay (30 seconds to 30 minutes)	
Adjustable cut off delay (none, 1/2 of time delay)	
Ramp and fade times (2 seconds; 10 seconds)	
Photocell On/Off levels (On 5 fc, Off 10 fc for at least 3 seconds)	
Operating temperature: -40°F to +158°F (-40°C to +70°C)	
Weight: FSP-202D, 2.89 oz (82 g); FSP-212D, 5.29 oz (150 g)	
UL and cUL listed (E101196)	
IP66 rated	
Five year warranty	
MATERIALS	
Polycarbonate	
Flame retardant	
UV resistant	
Impact resistant	
Recyclable	
Meets materials restrictions of RoHS	
FACTORY DEFAULTS	
Control mode:	Mode B
Trim level:	1V
Time delay:	15 minutes

* Not compatible with non-isolated LED drivers (FSP-212D only)

COVERAGE

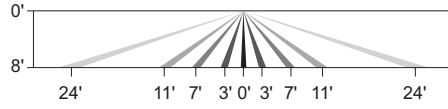
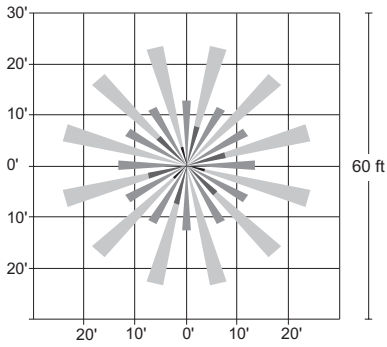

FSP-L2 top and side coverage patterns

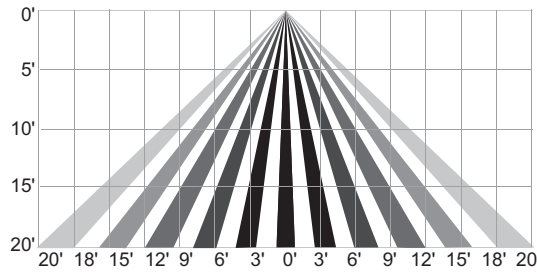
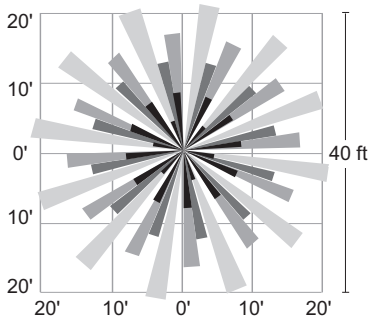

FSP-L3 top and side coverage patterns

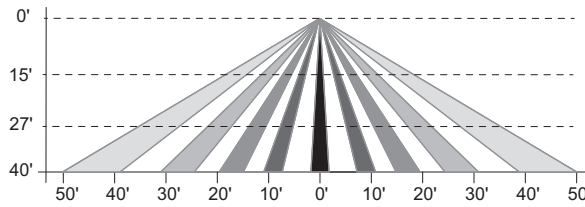
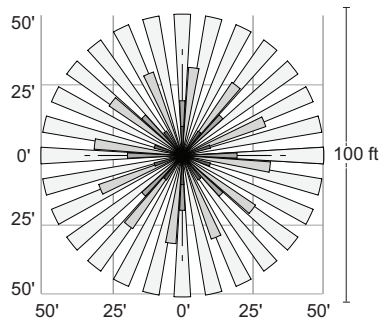

FSP-L7 top and side coverage patterns

DIMENSIONS OF LENS OPTIONS

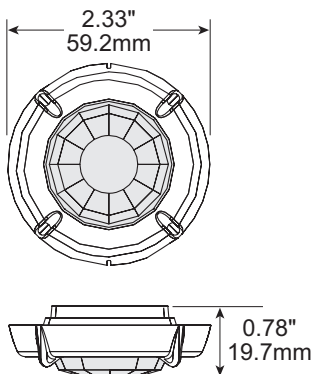

FSP-L2 dimensions

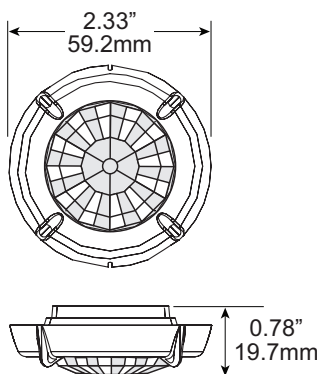

FSP-L3 dimensions

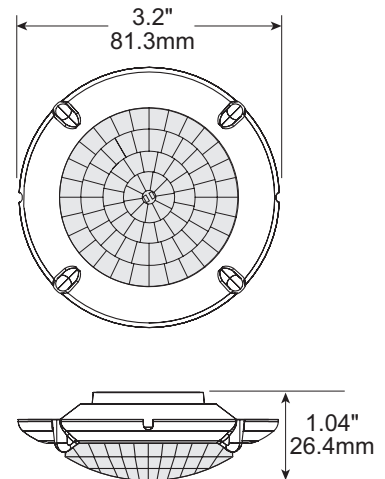

FSP-L7 dimensions

FSP-L2-S, FSP-L3-S, and FSP-L7-S Dimensions

The FSP-Lx-S models include a shroud, which blocks high-angle light coming from the fixture, to improve photocell performance. With the shroud attached, the dimensions for all three lenses are identical

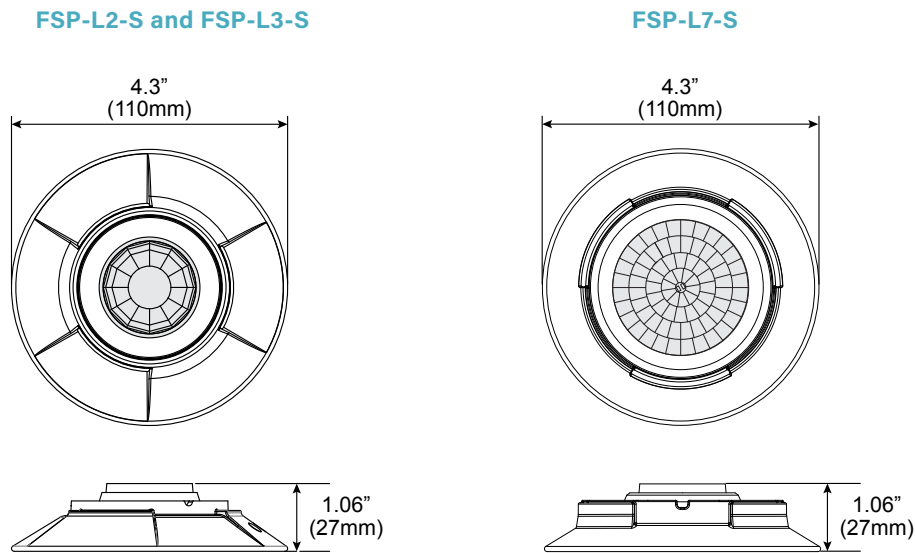

INSTALLING THE FSP-2X2D SENSOR IN LIGHT FIXTURE

1. Determine an appropriate mounting location inside the light fixture. Allow a minimum distance of 0.2" (5.1mm) from the end of the sensor to the wall of the fixture.
2. Drill a 1.30" (33mm) diameter hole through the sheet metal in the bottom of the fixture.
3. Place the rubber gasket on the threaded collar, and install the sensor face down, parallel to the mounting surface. Ensure the rubber gasket touches the inside surface of the fixture. Install the collar and torque to 25-30 in-lbs to maintain IP rating.
4. Align the locking features between the sensor and lens module and push the lens module forward until the O-ring seals firmly. Turn the lens module clockwise to lock in place.
5. Connect load, supply and control wires.
6. Restore power from the circuit breaker.

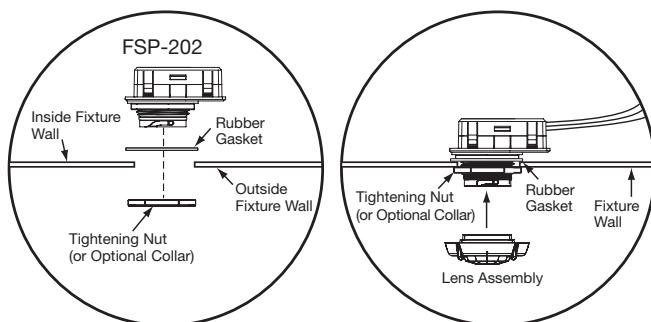

Figure 1. Installing the FSP-202D in the light fixture

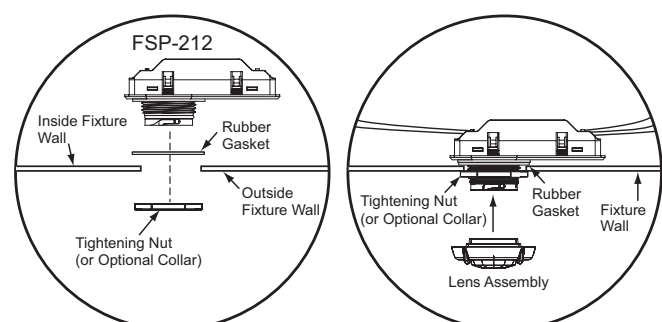

Figure 2. Installing the FSP-212D in the light fixture

NOTE: The outside fixture wall thickness should be no greater than 0.125" (3.18mm) for optimal sensor mounting and security.

WIRING DIAGRAMS FOR LOW VOLTAGE FSP-202D SENSORS

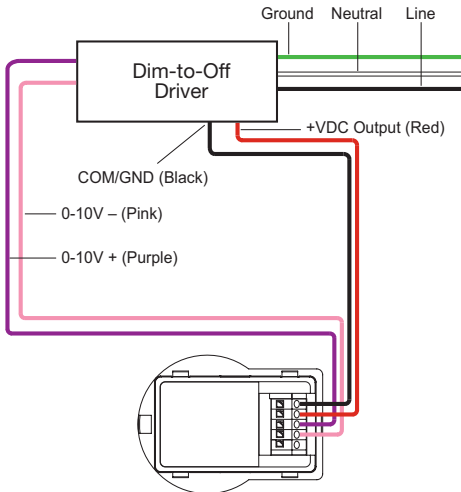

Figure 3. FSP-202D wiring with dim-to-off ballast or LED driver

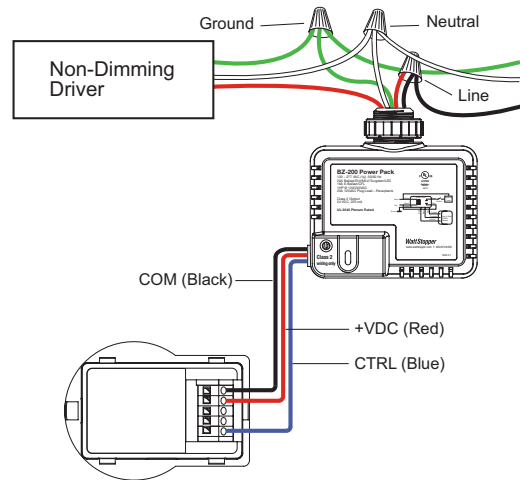

Figure 4. FSP-202D wiring with non-dimming ballast or LED driver and power pack for on/off control

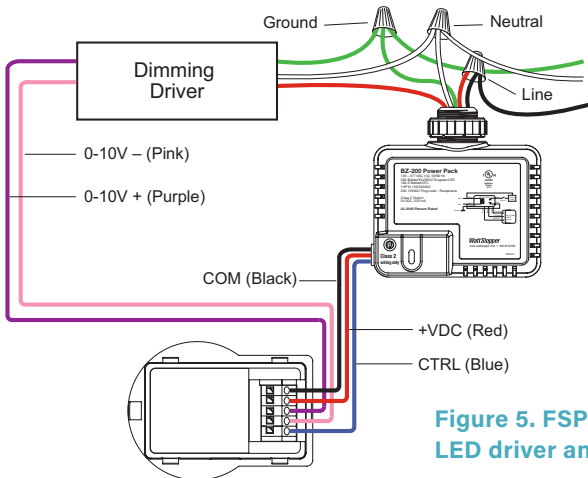

Figure 5. FSP-202D wiring with dimming ballast or LED driver and power pack for on/off control

NOTE: Per UL, the 0-10V negative dimming wire color has been changed from gray to pink.

WIRING DIAGRAMS FOR LINE VOLTAGE FSP-212D SENSORS

NOTE: The FSP-212D is not compatible with non-isolated LED drivers.

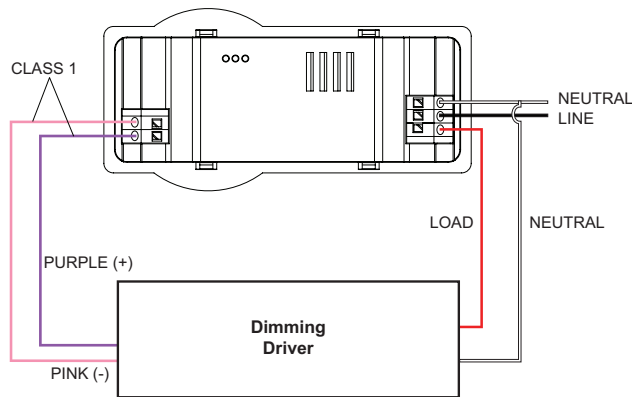

Figure 7. FSP-212D wiring with dimming ballast or LED driver

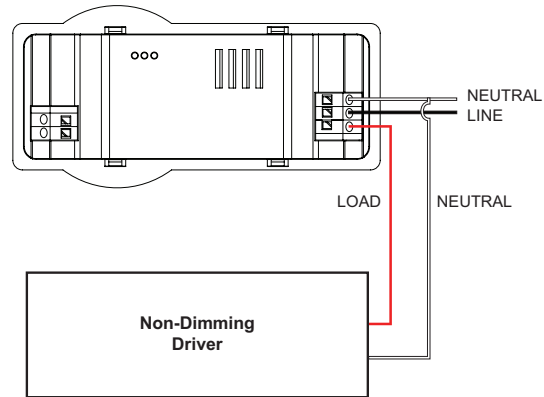

Figure 8. FSP-212D wiring with non-dimming load

ADJUSTING THE SENSOR VIA CONTROL MODES

The FSP-202D has five selectable modes, each of which has preset parameter settings. Once the mode is selected, you have the ability to further customize operation by adjusting the Set and the Time rotary trimpots.

Select the **Mode** and adjust the other rotary trimpots using a small screwdriver. Note: A sixth mode, Test mode, is accessed automatically when mode A is selected.

Set - This rotary trimpot is used to adjust three different parameters, depending on the current mode: **Desired Light Level** (in foot candles), **Hold Off Setpoint**, and **High Trim**.

- The FSP-202D has a photocell which measures the ambient light continuously. **In Modes B, C, and D**, this trimpot will adjust the **Desired Light Level**, with a range from 0 footcandles to 200 footcandles, and the FSP-202D will then adjust the dimming of the load so that the combined amount of ambient light and electric light reaches the desired light level. When this trimpot is set to the minimum position, the daylight control is disabled and the FSP-202D will adjust the light level based only on occupancy without regard to ambient light.
- In Mode A**, this trimpot determines the light level for the **Hold Off Setpoint**, with a range from 0 footcandles to 200

footcandles. When set to the minimum position, the light level hold off set-point is disabled.

- In Mode E**, this trimpot controls the current dimming level, allowing visual confirmation of the **High Trim** level. The high trim level is used to calculate the low dim amount, which varies based on the mode, as described below. It also determines the maximum lighting level in Mode A, and if the photocell is disabled, determines the maximum lighting level for Modes B, C, and D.

Time - This rotary trimpot sets the amount of time delay after occupancy is no longer detected before the loads go to the Low Trim value. Additionally, for Modes A and B, this controls the amount of time before the load goes from the Low Trim to OFF. The time will be half of the initial delay. For example, if time is set to 20 minutes, the load will go from ON to the Low Trim level 20 minutes after occupancy is no longer detected. The load will then turn OFF 10 minutes after it goes to the Low Trim level.

Fade Time - For all modes except Mode E and Test Mode, the fade up time from OFF to ON or OFF to High Dim Level is 2 seconds, and the fade down time from ON to Low Dim Level or Low Dim Level to OFF is 10 seconds. For Mode E and Test Mode, fade up and fade down time is 0 seconds.

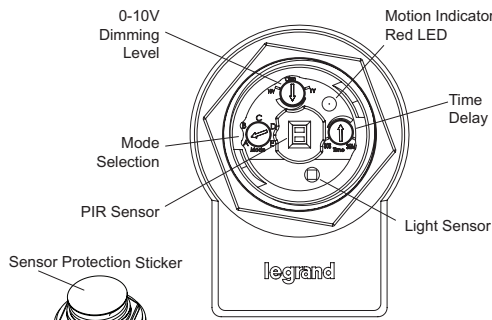

NOTE: Remove Sticker before use

FSP-202D sensor module

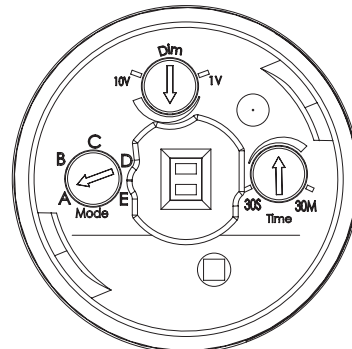

Control pot detail

CONTROL MODE SEQUENCES OF OPERATION

Mode A - High/Low/Off Dimming for Indoor Parking Structure or High-Bay

Features: Transition between High, Low, and Off levels; Adjustable Hold Off Setpoint; High trim and low dim levels are variable

This mode has a hold off light level set point, which can be adjusted to the desired light level using **Set** trimpot, or disabled (when the **Set** trimpot is turned to the minimum setting).

Anytime occupancy is detected with ambient light level below the hold off set point, the load turns ON (ramping up to the High trim level).

NOTE: In this mode, since there is no daylighting control, the High Trim level will be the maximum amount of light for the load. (The High Trim level is set in Mode E.)

Once no occupancy is detected and the time delay expires, the load will fade down to the Low Dim level which is 10% of High Trim level. As long as the area remains unoccupied, the load stays at the Low Dim level for half the amount of the time delay, and then load turns OFF.

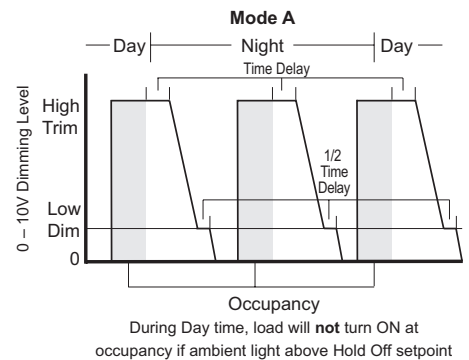

When the hold off light level set point is enabled using the **Set** trimpot, once the Load turns OFF, after 5 seconds if the

ambient light level is more than the set point value, the load will stay OFF even if occupancy is detected. But if occupancy is detected within the 5 seconds, the load will return to the High Trim value, even if the ambient light level is more than the hold off level.

NOTE: When you select mode A, The FSP-202D will initially enter Test mode and stay in test mode for 5 minutes, after which it will switch to mode A operation. (Test Mode is identical mode to A, with the exception of Time Delay, which is fixed at 5 seconds.)

Mode B - Continuous Dimming Control with Daylighting (Dim to Off)

Features: Adjustable photocell level to set desired light level when occupied

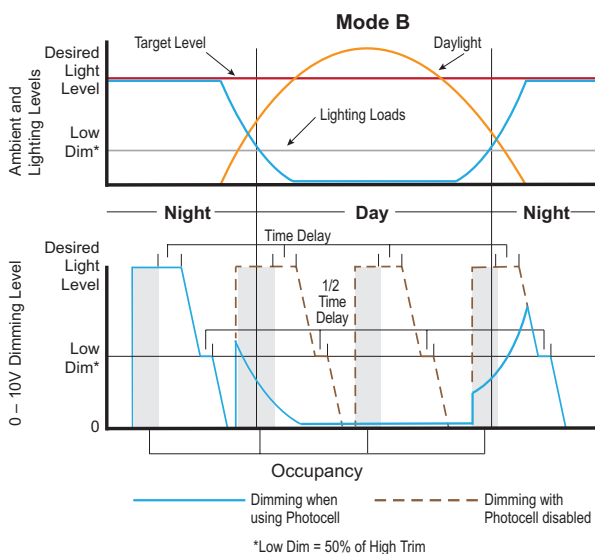

When the ambient lighting is below the desired light level and occupancy is detected, the sensor turns the loads ON. The dimming level continually adjusts so that the dimming amount combined with ambient light matches the desired light level. If the ambient lighting is above the desired light level when occupancy is detected, the load will remain OFF until the ambient light drops below the target level, at which point it will adjust the dimming level appropriately.

Once no occupancy is detected and the time delay expires, the load fades down to the Low Dim level, which is 50% of the High Trim level. As long as the area remains unoccupied, the load stays at the Low Dim level for half the amount of the time delay, and then load turns OFF. If the current dimming level is less than half of the High Trim value, the load fades down to OFF without any time delay.

NOTE: With the photocell enabled in this mode (as well as in modes C and D), the High Trim is used only to calculate the Low Dim amount. It can therefore be set to an amount lower than the maximum dimming amount, which is set based on the desired light level. For example: if the High Trim level is set to 8V, in Mode B the Low Dim level will be 4V. But if the desired light level is set high, the lights might go up to 9V or 10V in

order to reach the desired level.

NOTE: If the photocell is disabled in this mode (as well as in modes C and D), the High Trim amount will be used to determine the desired light level, as it does in Mode A.

Mode C - Continuous Dimming Control with Daylighting (Dim to Low Level)

Features: Adjustable photocell level to set desired light level; a minimum light level is always maintained.

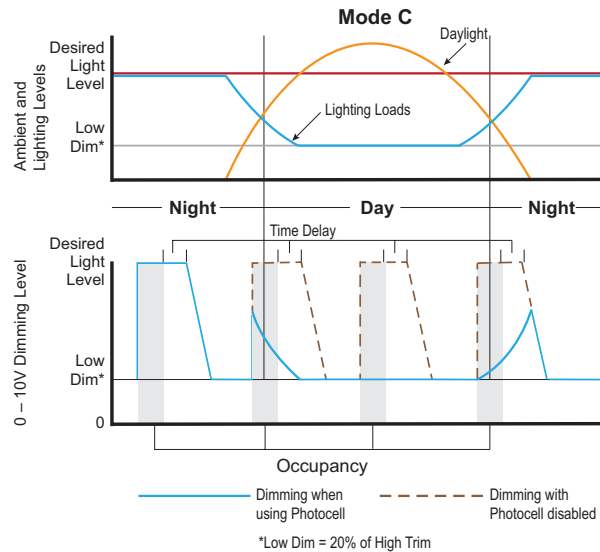

When occupancy is detected and if the ambient lighting is below the desired light level, the dimming level continually adjusts so that the dimming amount combined with ambient light matches the desired light level. If the ambient lighting is above the target photocell level, the dimming level will adjust to the Low Dim level (20% of High Trim value).

Once the area is unoccupied and the time delay expires, the load level will fade down to the Low Dim level (20% of High Trim value). The load will never turn completely OFF.

Mode D - Continuous Dimming Control with Daylighting (Separate Low Dim Levels when there is No Occupancy)

Features: Adjustable photocell level to set desired light level; a minimum light level is always maintained, with separate day time and night time minimum levels

During the day time, when occupancy is detected and if the ambient lighting is below the desired light level, the dimming level continually adjusts so that the dimming amount combined with ambient light matches the desired light level. Once the dimming level reaches 40% of the high trim level, the sensor will consider it to be night time and will behave as described in the following paragraph. If the ambient lighting is above the target photocell level, the dimming level will adjust to the Day Time Low Dim level (20% of High Trim value). Additionally, when there is no occupancy and the time delay expires, the load level will fade down to the Day Time Low Dim level.

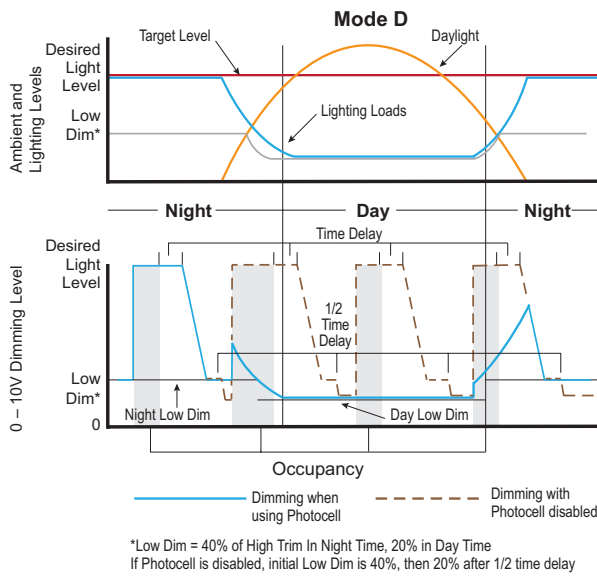

During the night time, when occupancy is detected, the dimming level adjusts to the desired light level. When there is no occupancy and the time delay expires, the load level will fade down to the Night Time Low Dim level (40% of High Trim value) in order to maintain a safe light level. Once the dimming level is less than 40% of the high trim operation, the sensor switches back to day time operation.

In this mode, the load will never turn completely OFF.

NOTE: If the photocell is disabled, then the day time/night time behavior does not apply. In this case, after the time delay expires the lights will dim to 40% of the High Trim level, and then after an additional 1/2 of the time delay amount, the lights will dim further to 20% of high dim level.

Mode E - Service/Setup Mode

Features: Allows visual adjustment of High Trim level

If the **Time** trimpot is set at maximum, the load turns ON at the current High Trim amount. Adjust the **Set** trimpot to the desired amount. This amount will be the maximum amount of light in Mode A and will set the High Trim amount for Modes, B, C, and D. If the **Time** trimpot is set at minimum, the load turns OFF.

Note that after turning the Time trimpot to change the ON/OFF setting, the unit will not respond to further changes for 3 seconds.

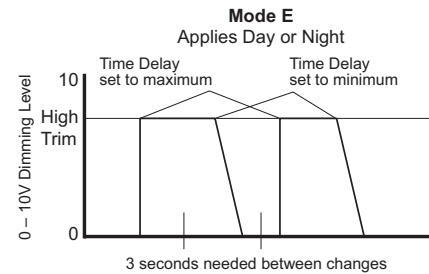

Test Mode

Test mode sets the time delay to 5 seconds to allow for testing the occupancy sensor.

Whenever Mode A is selected using the **Mode** trimpot, the FSP-202D will enter Test mode for 5 minutes. If the FSP-202D is currently in mode A, selecting another mode and then returning to mode A will restart Test mode. During Test mode, daylight control is not active and the value of the Time trimpot is overridden. When occupancy is detected the load will turn ON at the High Trim value. Once no occupancy is detected, the load will go to the Low Dim level after 5 seconds, and then will stay at that level for 2.5 seconds, before turning OFF. After 5 minutes, the unit will revert to normal Mode A operation.

	Daylighting Control	High/Low Dim	Time Delay	Auto On	Auto Off
Mode A	No	High Trim/ 10% of High Trim	30sec – 30 min 1/2 of set value during Low Trim	Occupancy detected	One half time delay expired
Mode B	Yes	High Trim/ 50% of High Trim	30sec – 30 min Default – 15 min	Occupancy detected	One half time delay expired or ambient light level above target photocell level
Mode C	No	High Trim/ 20% of High Trim	30sec – 30 min	Occupancy detection	One half time delay expired
Mode D	Yes	High Trim/ 20% of High Trim in Day 40% of High Trim at Night	30sec – 30 min 1/2 of set value during Low Trim	Load is always ON	Time delay expired or ambient light level above 10 fc
Mode E	No	High Trim	Not applicable	Load is ON at Dim level when time delay rotary trimpot in maximum position	Load is OFF when time delay trim in minimum position

ORDERING INFORMATION

Catalog #	Master Pack Details					Inner Pack Details				
	Master Pack Quantity	Case dimensions (inches)			Weight (pounds)	Inner Pack Quantity	Case dimensions (inches)			Weight (pounds)
		Length	Width	Height			Length	Width	Height	
FSP-202D	200	21.14	19.72	10.31	22.16	100	20.67	9.5	9.8	10
FSP-212D	200	21.14	19.72	10.31	36.27	100	20.67	9.5	9.8	16.4
FSP-L2	400	16.14	15.35	18.74	21.6	100	15.5	7.32	8.6	4.82
FSP-L3	400	16.14	15.35	18.74	20.3	100	15.5	7.32	8.6	4.82
FSP-L7	100	23.82	16.22	9.69	10.74	50	23.03	7.72	8.58	4.72

Catalog #	Color	Description	Voltage
<input type="checkbox"/> FSP-202D	White	Fixture mount, passive infrared motion sensor, low voltage	12-32 VDC
<input type="checkbox"/> FSP-212D	White	Fixture mount, passive infrared motion sensor	120-277VAC, 50/60Hz
<input type="checkbox"/> FSP-L2	White	360° lens, maximum coverage 48' diameter from 8' height	
<input type="checkbox"/> FSP-L2-B	Black		
<input type="checkbox"/> FSP-L2-BR	Bronze		
<input type="checkbox"/> FSP-L2-G	Grey		
<input type="checkbox"/> FSP-L2-S	White		
<input type="checkbox"/> FSP-L3	White	360° lens, maximum coverage 40' diameter from 20' height	
<input type="checkbox"/> FSP-L3-B	Black		
<input type="checkbox"/> FSP-L3-BR	Bronze		
<input type="checkbox"/> FSP-L3-G	Grey		
<input type="checkbox"/> FSP-L3-S	White	360° lens, maximum coverage 40' diameter from 20' height, with shroud; Minimizes high-angle light contribution to photocell	
<input type="checkbox"/> FSP-L7	White	360° lens, maximum coverage 100' diameter from 40' height	
<input type="checkbox"/> FSP-L7-B	Black		
<input type="checkbox"/> FSP-L7-BR	Bronze		
<input type="checkbox"/> FSP-L7-G	Grey		
<input type="checkbox"/> FSP-L7-S	White	360° lens, maximum coverage 100' diameter from 40' height, with shroud; Minimizes high-angle light contribution to photocell	
<input type="checkbox"/> FSP-C1-W	White	Small collar, for use with FSP-L2 and FSP-L3 lenses (Optional aesthetic collar to transition from fixture housing to lens) Note: Not used with lenses that include shroud	
<input type="checkbox"/> FSP-C2-W	White	Large collar, for use with FSP-L7 lens (Optional aesthetic collar to transition from fixture housing to lens) Note: Not used with lens that includes shroud	

Note: Unless used with a driver or ballast with a low voltage power supply, the FSP-202D requires a Wattstopper power pack (ordered separately) to operate. FSP-Lx series lens required for operation; order lens separately.

*Product is compliant with Buy American Act and Trade Agreement Act